



Modular Series Panel PC

Configurable, Plug-in Display and IPC Family

The Modular Series from Computer Dynamics offers a brand-new way to think about Panel PCs in the Industrial space. Display fronts and IPC backs can be interchanged easily giving you a highly reliable, rugged solution that can easily be serviced by your maintenance team. Or, if you prefer, replacement parts can be ordered and delivered the following day for maximum up-time. All of the different size display fronts can be attached to Any computer back giving you the exact display size and performance needed for your application. All modular panels come with a resistive touchscreen and the IPCs can be loaded with Windows 7 or Windows 8. All backs and fronts work together with no user configuration required.

Modular Series Panel-Mount Display and IPC Solution

Specifications

Display

- 15" 1024x768 16.2M color; 400 nit
- 19" 1280x1024 16.7M color; 350 nit
- 21.5" 1920x1080 16.7M color; 250 nit

Contrast Ratio (typical)

- 700:1 (15")
- 1000:1 (19")
- 1000:1 (21.5")

Viewing Angles

- +/- 80 X axis; -60 to 80 Y axis (15")
- +/- 85 X axis; +/- 80 Y axis (19")
- +/- 85 X axis; +/- 80 Y axis (21.5")

Environmental

- 0° to +50°C (operating)
- -20 to +60°C (storage)
- IP66 Panel Mount

Touchscreen

- Resistive

Rear Connector

- Mates with any Modular IPC

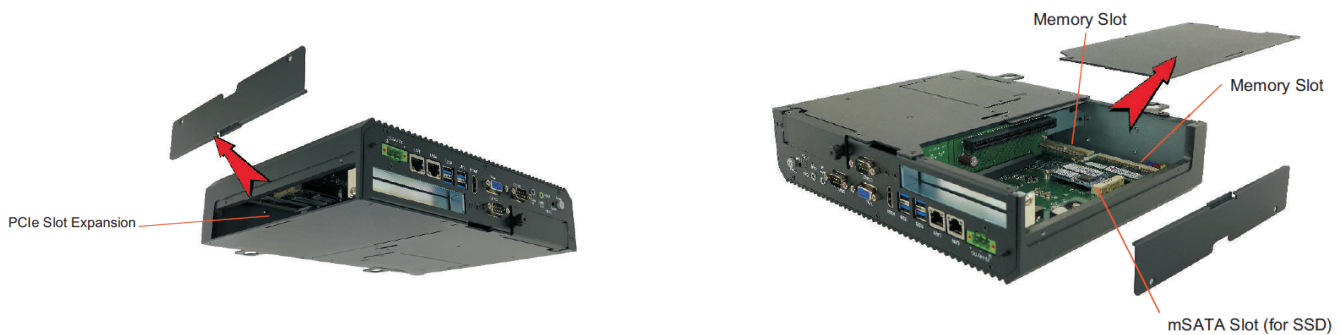
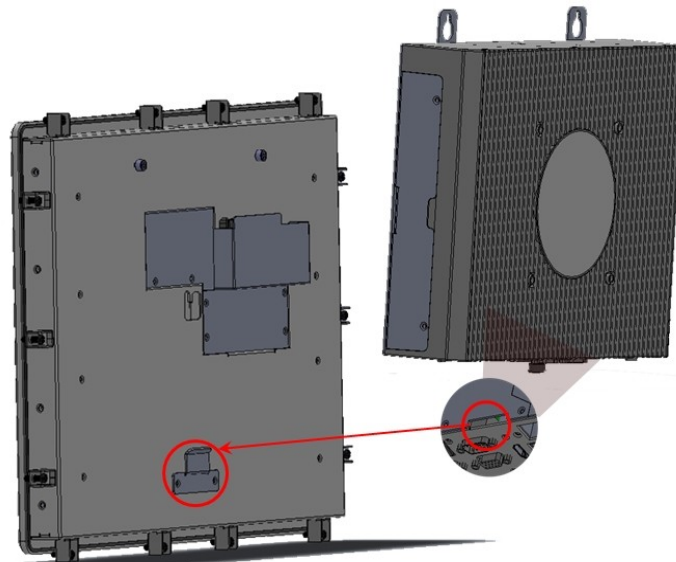



Modular Series IPC

Configurable, Plug-in Display and IPC Family (i5 Version)

Features

- Fanless computer
- Intel®Core i5-4200U 2.6GHz processor
- SODIMM DDR3L-1600; 16GB maximum
- 2x Serial ports: 1x RS232/422/485, 1x RS232
- 4x USB3.0
- 2x Gigabit LAN (RJ45)
- 0C to 50C operational temp
- 9-36V DC power input
- External AC Power Supply Provided

Processor

- Intel Core i5-4200U 2.6GHz

BIOS

- AMI UEFI BIOS

Graphic Chipset

- Intel HD Graphics 4400

Memory

- 2x SODIMM sockets. 4GB Standard
Max 16GB DDR3L-1600

I/O Connectors

- 4x USB 3.0
- 2x Gigabit LAN
- 1x RS232/422/485
- 1x RS232
- VGA
- HDMI
- Audio In/Out
- Power and Reset Buttons
- SSD Activity Indicator
- 9-36V Isolated DC (3pin terminal block)

Storage

- 2x SATA HDD and SSD options available
- Removable

Expansion

- 1x PCIe x4

Power Input

- 9-36V DC input

Environmental

- 0° to 50° C Op Temp
- 30-95% RH @ 40C (non-condensing)

Construction

- Aluminum extrusion and steel, IP40

Dimensions (LxWxH)

- 10.81" x 8.14" x 2.37"
275 mm x 207 mm x 61 mm

O/S Support

- Windows 7 (hard drive)
- Windows 10 (hard drive or SSD)
- XPE, WES, WES7, Compact 7 (SSD)



Modular Series IPC

Configurable, Plug-in Display and IPC Family (ATOM Version)

Features

- Fanless computer
- Intel®ATOM™ E3845 1.9GHz processor
- SODIMM DDR3L-1600; 16GB maximum
- 1x Serial ports: RS232/422/485
- 4x USB 2.0
- 2x Gigabit LAN (RJ45)
- 0C to 50C operational temp
- 9-36V DC power input
- External AC Power Supply Provided

Processor

- Intel ATOM E3845 1.9GHz

BIOS

- AMI UEFI BIOS

Graphic Chipset

- Intel HD Graphics

Memory

- 2x SODIMM sockets. 4GB Standard
Max 16GB DDR3L-1600

I/O Connectors

- 4x USB 2.0
- 2x Gigabit LAN
- 1x RS232/422/485
- VGA
- HDMI
- Audio In/Out
- Power and Reset Buttons
- SSD Activity Indicator
- 9-36V Isolated DC (3pin terminal block)

Storage

- 1x SATA HDD and SSD options available
- Removable

Power Input

- 9-36V DC input

Environmental

- 0° to 50° C Op Temp
- 30-95% RH @ 40C (non-condensing)

Construction

- Aluminum extrusion and steel, IP40

Dimensions (LxWxH)

- 10.87" x 9.01" x 1.78"
276 mm x 229 mm x 45 mm

O/S Support

- Windows 7 (hard drive)
- Windows 10 IoT
- XPE, WES, WES7, Compact 7 (SSD)

About Computer Dynamics

Computer Dynamics (A CIMTEC Automation Company) is a leading global provider of flat panel display solutions for a wide range of industries and applications. Our comprehensive product offering includes open-frame, enclosed, and environmentally sealed flat panel display systems in both computer and monitor configurations. Whether you're looking for one of our standard products or a fully custom solution, Computer Dynamics has the breadth, experience and support to deliver what you need. For more than 25 years, CIMTEC Automation has been providing automation solutions throughout the world that deliver value, performance, and innovation.

Computer Dynamics Contact Information

Americas: 1 864 627 8800

Additional contact information available on our web site at www.cdynamics.com/contact.asp