



Series Six Programmable Controllers

GEK-90824D
July 1989

Input/Output Communications Control Module (I/O CCM) IC600BF948

General Description

The Input/Output Communications Control Module (I/O CCM) provides a serial data link between the CPU of a Series Six programmable controller and many other devices. Some devices which can be connected are:

- CCM2, CCM3, or I/O CCM in a Series Six PLC.
- Data Communications Unit (DCU) in a Series One, or Series One Plus or Series One Junior PLC.
- Data Communications Module (DCM) in a Series Three PLC.
- VuMaster and Factorymastersoftware running on the Workmaster computer.
- Intelligent devices such as a host computer.
- Process Control Systems.

The I/O CCM contains two independently configurable serial ports. Both ports support RS-232 and **RS-422** serial interfaces, with Port 1 also supporting active/passive 20 mA current loop. Both ports support asynchronous serial communications with data rates of up to 19.2 Kbps. The user may select any of the following options using DIP switches.

Data rate: 110 to 19.2 Kbps. Maximum data rate is limited to 4800 Kbps for current loop operation on Port 1.

Protocol type: For CCM mode -- master, slave, or peer. For Remote Terminal Unit (RTU) mode -- RTU slave.

Parity: even odd, none

Turn-around delay: 0 or 500 ms, Port 2 only.

The features and benefits of the I/O CCM are given in Table 1.

Table 1. Features and Benefits

FEATURES	BENEFITS
Contains two programmable communications interfaces.	Permits a data link between the Series Six PLC and a host computer, programmable terminals, and other intelligent devices.
Multiple modules per Series Six PLC.	Permits communication ports as required.
Redundant communications.	Permits duplication of communication hardware and separate data paths by using two I/O CCM modules for each Series Six CPU.
Interfaces to process control systems.	Allows the Series Six PLC to be used with process control systems.
Ability within the user logic program to initiate a data transfer or request to a host computer or another intelligent device.	Allows the Series Six PLC to act as a master or peer in its relationship with other PLC's, host computers, or smart terminals.
On-board diagnostics and board fault indicator lights.	Simplifies troubleshooting and indicates correct data transfer.

The I/O CCM can be used in communications systems using:

- Multidrop modem based links
- Multidrop RS-422 links
- Radio links (port 2 only)

NOTE

As a master device port 1 or port 2 can be used in multidrop configuration; As a slave device only port 2 can be used in multidrop configurations.

The module provides isolation of the serial port receivers and transmitters and also provides 1500 volts of isolation protection from port to port and from the ports to the rest of the Series Six PLC system.

Six Light-Emitting Diodes (LEDs) show port activity and module status. If the on-board power-up diagnostics detect a failure, the BOARD OK LED will remain OFF and the lower five LEDs will provide an error code to specify the error. (See Table 5 for the specific power-up error codes).

The CPU COMM LED blinks to indicate communications between the I/O CCM module and the Series Six CPU.

The remaining four LEDs show port activity of the transmitters and receivers on both ports. They will BLINK when a port is communicating and will be OFF when an error occurs on a particular port.

The I/O CCM may be inserted in a high-capacity I/O rack or a Series Six CPU rack I/O slot.

Table 2, RS-232C/RS-422 Cable Specifications

Length, Maximum - 50 feet (15 meters) for RS-232C;
4000 feet (1.2Km) for RS-422;
1,000 feet (305 meters) for current loop.

Overall Shield Recommended

24 AWG Minimum

Mating connector to Port 1 or Port 2 is a D-Subminiature Type. Cannon DB25P (Solder Pot) with DB11096B-3 Hood or Equivalent. (Standard RS-232C male connector.)

The following cables provide acceptable operation at data rates up to 19.2 Kbps and distances up to 4000 feet.

Belden - 9184
Belden - 9302
NEC - 222PISLCBT

At shorter distances, almost any twisted pair or shielded twisted pair cable will work. It should be noted that RS-422 requires that the transmitter and receiver ground be within a few millivolts of each other or damage to the transmitter and receiver may result.

It is also noted that the twisted pairs should be matched so that both transmit signals make up one twisted pair and both receive signals make up the other twisted pair. If this is ignored, then cross-talk can result from the mis-matching which may affect the performance of the communication system.

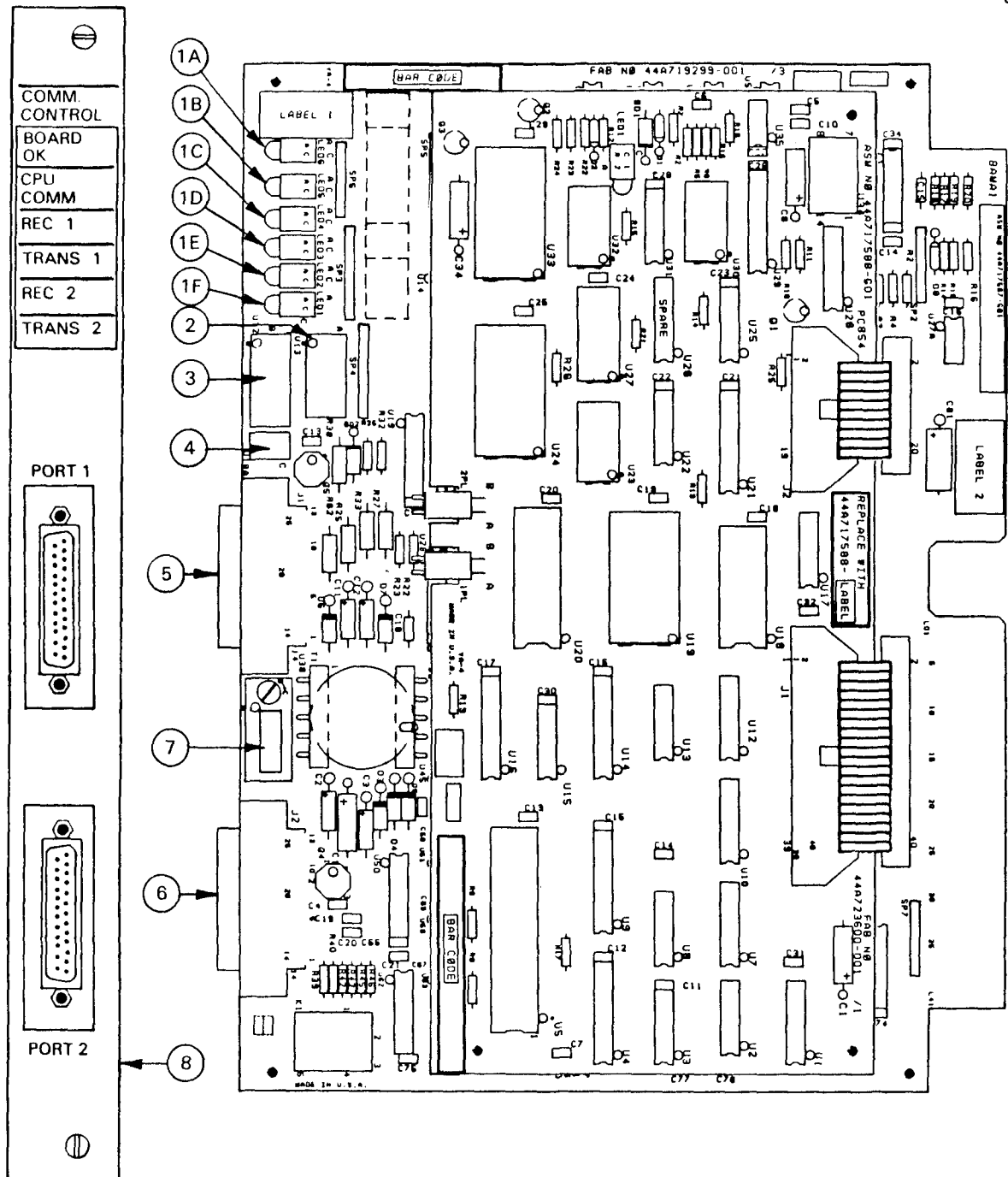

Figure 1. User Items

- | | |
|--|---|
| <ul style="list-style-type: none"> 1. LED Status Indicators (see Table 3). 2. Bank A DIP Switches. 3. Bank B DIP Switches. 4. Bank C DIP Switches. 5. J1 Connector: 25-pin D-type female connector (Communications Port 1). | <ul style="list-style-type: none"> 6. J2 Connector; 25-pin D-type female connector (Communications Port 2) 7. J2 Communication selection DIP package: RS-232 or RS-422 configuration. Read from top of imprinted label. 8. Faceplate |
|--|---|

Table 3. LED Status Indicators

LED		DESCRIPTION
(IA) BOARD OK	ON: FLASHING: OFF:	Board has passed self-diagnostics and is operating properly. Invalid slave ID when either port is configured as a slave. Board has failed self-diagnostics (see Table 5).
(1B) CPU COMM	FLASHING ON:	Board is communicating with the Series Six CPU properly. The rate of blink indicates the frequency of CPU communication windows. No communication between the Series Six CPU and the board. (Check DPREQ in ladder diagram and backplane DIP switches for the I/O slot if not flashing).
(1C) REC 1	ON: FLASHING: OFF:	Port 1 serial data communications normal. Serial data being received on Port 1. Port 1 serial data communications error occurred due to parity errors, bad blocks, or serial link timeout.
(1D) TRANS 1	ON: FLASHING: OFF:	Port 1 serial data communications normal. Serial data being transmitted on Port 1. Port 1 serial data communications error occurred due to parity errors, bad blocks, or serial link timeout.
(1E) REC 2	ON: FLASHING: OFF:	Port 2 serial data communications normal. Serial data being received on Port 2. Port 2 serial data communications error occurred due to parity errors, bad blocks, or serial link timeout.
(1F) TRANS 2	ON: FLASHING: OFF:	Port 2 serial data communications normal . Serial data being transmitted on Port 2. Port 2 serial data communications error occurred due to parity errors, bad blocks, or serial link timeout.

Table 4. Serial Data Format

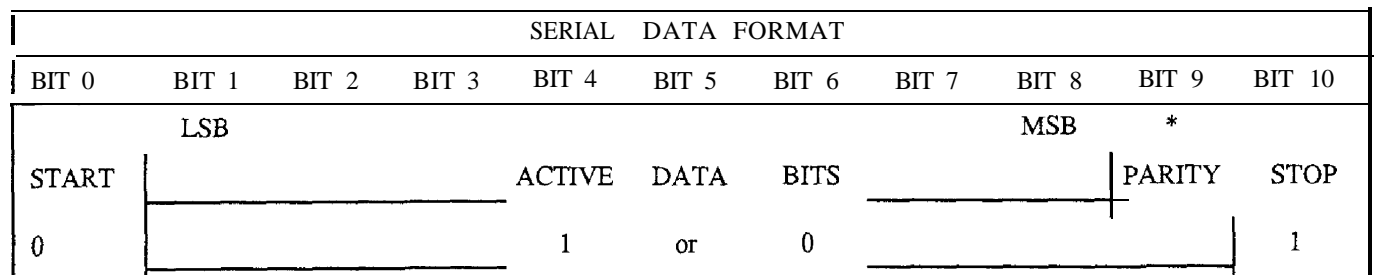

* Parity can be disabled on either port.

GEK-90824D

If the BOARD OK light turns OFF after the power up self-diagnostics routine, the indicator lights will create one of the patterns below:

Table 5. Power-up Error Codes (• light on, ° light off)

LED	CODE 1	CODE 2	CODE 3	CODE 4	CODE 5	CODE 6	CODE 7
BOARD OK	0	0	0	0	0	0	0
CPU COMM	0	0	0	0	0	0	0
REC 1	0	0	0	0	0	0	•
TRANS 1	0	0	0	0	•	•	•
REC 2	0	0	•	•	0	0	0
TRANS 2	0	•	0	•	0	•	•

<u>Code</u>	<u>Description</u>	<u>Code</u>	<u>Description</u>
1	Processor test failed	5	EPROM test failed
2	Timer 0 test failed	6	RAM test failed (E000-FFFF); board location, U20
3	Timer 1 test failed	7	RAM test failed (C000-DFFF); board location, U19
4	Timer 2 test failed		

Installation

To install and operate the I/O CCM you must complete the following steps.

1. Calculate the power requirements for the rack which will contain the I/O CCM.
2. Set the I/O CCM address using the backplane DIP switches. (Reference Figure 3, Table 6)

Refer to a later section, "Running at the DPU Executive Window", to set the I/O CCM module to run at the DPU address.
3. Configure the communications port using the on-board DIP switches. (Tables 7, 8, 9)
4. Check the RS-232/RS-422 DIP pack for desired orientation - Port 2 only. (Reference Figure 2)
5. Insert I/O CCM in the rack.
6. If not running at the DPU executive window, program the [DPREQ] or [WINDOW] instruction to establish windows between the I/O CCM and the CPU. The [WINDOW] instruction is valid for CPU microcode Version 130 and thereafter.
7. Program the registers containing the communications command and parameters for the required transfer of data if the I/O CCM is to initiate communications.

8. Set up valid CPU ID number through the CPU scratch pad.
9. Construct and install cable. (Reference Figures 5, 6, 7, and 8)

Power Requirements for the I/O CCM

The I/O CCM may be installed in a Series Six CPU rack I/O slot, the Series Six High-Capacity I/O rack, or a Series Six Plus CPU rack.

The Series Six CPU rack can support a maximum of 300 units of load. Consequently, four I/O CCMs can be powered by the Series Six CPU rack, and when no other loading exists for +12 Vdc, five I/O CCM modules may be installed.

A maximum of five I/O CCM modules can be powered by a high capacity I/O rack. In this case there are 140 units of load remaining for I/O modules with +5v power only.

When other types of I/O modules are to be placed in the same rack as an I/O CCM, calculate the power requirements of all the modules to ensure that the maximum power of the rack is not exceeded. Refer to the power requirements of the I/O CCM in Table 13, and to the appropriate manual or data sheet for other modules.

Positioning the RS-422/RS-232 Hybrid Dip Package

The RS-422/RS-232 hybrid DIP package affects the operation of port 2 only. Verify the position of the configuration hybrid DIP package located between ports J1 and J2. It is marked "232" on one end and "422" on the other end and is mounted on a zero insertion force socket.

Use a small screwdriver to turn the screw which releases the configuration hybrid DIP package from tie socket. Position the package with the desired interface type (RS-232 or RS-422) closest to port J1. See Figure 2 for proper orientation.

a42442

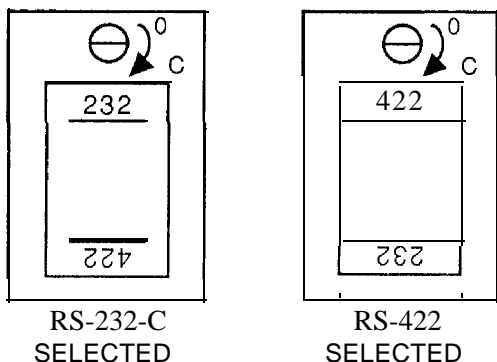

Figure 2. RS-232/RS-422 Hybrid DIP Package (for Port 2)

Setting the Module Address

Before installing the module, set the Dual-In-Line Package (DIP) switches adjacent to the card slot on the rack backplane to establish which group of eight consecutive input points in the CPU I/O tables will be used by the module being installed. Figure 3 illustrates a typical I/O DIP switch set for address 673-680 and Table 6 shows switch settings for all possible module addresses.

Refer to a later section "Running at the DPU Executive Window", to set the I/O CCM module to run at the DPU address.

a4244 1

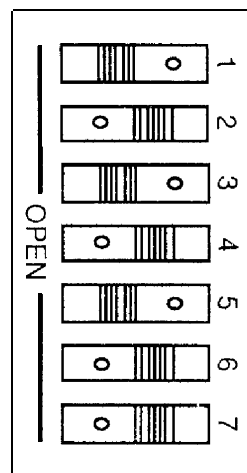

Figure 3. Typical I/O Backplane DIP Switch

GEK-90824D

Table 6. Setting the Backplane DIP Switch to Address the I/O CCM

b40478

DPREQ REGISTER CONTENTS DECIMAL (HEX)	I/O POINT	DIP SWITCH POSITION						DPREQ REGISTER CONTENTS DECIMAL (HEX)	I/O POINT	DIP SWITCH POSITION						
		7	6	5	4	3	2			1	7	6	5	4	3	2
1001 (03E9)	1- 8							1505 (05E1)	505- 512		X	X	X	X	X	X
1009 (03F1)	9- 16						X	1513 (05E9)	513- 520	X						
1017 (03F9)	17- 24					X		1521 (05F1)	521- 528	X						X
1025 (0401)	25- 32					X	X	1529 (05F9)	529- 536	X					X	
1033 (0409)	33- 40				X			1537 (0601)	537- 544	X					X	X
1041 (0411)	41- 48				X	X		1545 (0609)	545- 552	X				X		
1049 (0419)	49- 56				X	X		1553 (0611)	553- 560	X				X		X
1057 (0421)	57- 64				X	X	X	1561 (0619)	561- 568	X				X	X	
1065 (0429)	65- 72			X				1569 (0621)	569- 576	X				X	X	X
1073 (0431)	73- 80			X			X	1577 (0629)	577- 584	X			X			
1081 (0439)	81- 88			X	X			1585 (0631)	585- 592	X		X				X
1089 (0441)	89- 96			X	X	X		1593 (0639)	593- 600	X		X		X		
1097 (0449)	97- 104			X	X			1601 (0641)	601- 608	X		X		X	X	X
1105 (0451)	105- 112			X	X	X		1609 (0649)	609- 616	X		X	X			
1113 (0459)	113- 120			X	X	X		1617 (0651)	617- 624	X		X	X			X
1121 (0461)	121- 128			X	X	X	X	1625 (0659)	625- 632	X		X	X	X		
1129 (0469)	129- 136		X					1633 (0661)	633- 640	X		X	X	X	X	
1137 (0471)	137- 144		X				X	1641 (0669)	641- 648	X	X					
1145 (0479)	145- 152		X			X		1649 (0671)	649- 656	X	X					X
1153 (0481)	153- 160		X	X	X	X		1657 (0679)	657- 664	X	X				X	
1161 (0489)	161- 168		X	X				1665 (0681)	665- 672	X	X			X	X	
1169 (0491)	169- 176		X	X	X	X		1673 (0689)	673- 680	X	X	X				
1177 (0499)	177- 184		X	X	X			1681 (0691)	681- 688	X	X	X			X	
1185 (04A1)	185- 192		X	X	X	X		1689 (0699)	689- 696	X	X	X	X			
1193 (04A9)	193- 200		X	X				1697 (06A1)	697- 704	X	X	X	X	X	X	
1201 (04B1)	201- 208		X	X		X		1705 (06A9)	705- 712	X	X	X				
1209 (04B9)	209- 216		X	X	X			1713 (06B1)	713- 720	X	X	X				X
1217 (04C1)	217- 224		X	X	X	X		1721 (06B9)	721- 728	X	X	X	X			X
1225 (04C9)	225- 232		X	X	X			1729 (06C1)	729- 736	X	X	X	X	X		X
1233 (04D1)	233- 240		X	X	X	X		1737 (06C9)	737- 744	X	X	X	X			
1241 (04D9)	241- 248		X	X	X	X		1745 (06D1)	745- 752	X	X	X	X	X		X
1249 (04E1)	249- 256		X	X	X	X	X	1753 (06D9)	753- 760	X	X	X	X	X		X
1257 (04E9)	257- 264	X						1761 (06E1)	761- 768	X	X	X	X	X	X	X
1265 (04F1)	265- 272	X					X	1769 (06E9)	769- 776	X	X					
1273 (04F9)	273- 280	X				X		1777 (06F1)	777- 784	X	X					X
1281 (0501)	281- 288	X				X	X	1785 (06F9)	785- 792	X	X					X
1289 (0509)	289- 296	X		X				1793 (0701)	793- 800	X	X				X	X
1297 (0511)	297- 304	X		X	X			1801 (0709)	801- 808	X	X			X		
1305 (0519)	305- 312	X		X	X			1809 (0711)	809- 816	X	X			X	X	X
1313 (0521)	313- 320	X		X	X	X		1817 (0719)	817- 824	X	X			X	X	
1321 (0529)	321- 328	X	X					1825 (0721)	825- 832	X	X			X	X	X
1329 (0531)	329- 336	X	X			X		1833 (0729)	833- 840	X	X	X				
1337 (0539)	337- 344	X	X	X				1841 (0731)	841- 848	X	X	X				X
1345 (0541)	345- 352	X	X	X	X			1849 (0739)	849- 856	X	X	X	X			X
1353 (0549)	353- 360	X	X	X				1857 (0741)	857- 864	X	X	X	X	X		X
1361 (0551)	361- 368	X	X	X	X		X	1865 (0749)	865- 872	X	X	X	X			
1369 (0559)	369- 376	X	X	X	X			1873 (0751)	873- 880	X	X	X	X	X		X
1377 (0561)	377- 384	X	X	X	X	X		1881 (0759)	881- 888	X	X	X	X	X		X
1385 (0569)	385- 392	X	X					1889 (0761)	889- 896	X	X	X	X	X	X	X
1393 (0571)	393- 400	X	X			X		1897 (0769)	897- 904	X	X	X				
1401 (0579)	401- 408	X	X			X		1905 (0771)	905- 912	X	X	X				X
1409 (0581)	409- 416	X	X			X	X	1913 (0779)	913- 920	X	X	X				X
1417 (0589)	417- 424	X	X	X				1921 (0781)	921- 928	X	X	X			X	X
1425 (0591)	425- 432	X	X	X	X			1929 (0789)	929- 936	X	X	X	X			
1433 (0599)	433- 440	X	X	X	X			1937 (0791)	937- 944	X	X	X	X	X		X
1441 (05A1)	441- 448	X	X	X	X	X		1945 (0799)	945- 952	X	X	X	X	X	X	
1449 (05A9)	449- 456	X	X	X				1953 (07A1)	953- 960	X	X	X	X	X	X	X
1457 (05B1)	457- 464	X	X	X	X			1961 (07A9)	961- 968	X	X	X	X			
1465 (05B9)	465- 472	X	X	X	X			1969 (07B1)	969- 976	X	X	X	X			X
1473 (05C1)	473- 480	X	X	X	X	X		1977 (07B9)	977- 984	X	X	X	X	X		X
1481 (05C9)	481- 488	X	X	X	X			1985 (07C1)	985- 992	X	X	X	X	X	X	X
1489 (05D1)	489- 496	X	X	X	X	X		1993 (07C9)	993- 1000	X	X	X	X	X	X	X
1497 (05D9)	497- 504	X	X	X	X	X										

* For programming use only: add 1000 to I/O points.

X = Switch in OPEN Position (Depressed to the Left).

Configuring the Communications Ports

Set the DIP switch banks A, B, and C (user items 2, 3, and 4 on Figure 1) on the module to the required configurations (see Tables 7, 8, and 9).

Table 7. Configuration Switches for Port 1 (Bank A)

		SWITCH		FUNCTION
1	2	3	<u>Data Rate Selection</u>	
open	open	open	110 bps	
closed	open	open	300 bps	
open	closed	open	600 bps	
closed	closed	open	1200 bps	
open	open	closed	2400 bps	
closed	open	closed	4800 bps**	
open	closed	closed	9600 bps	
closed*	closed**	closed*	19.2 Kbps*	
4	5	6	<u>Protocol Selection</u>	
open	open	open	CCM Master RS-232/RS-422	
closed	open	open	CCM Master Current Loop**	
open	closed	open	CCM Slave RS-232/RS-422	
closed	closed	open	CCM Slave Current Loop**	
open*	open*	closed*	CCM Peer RS-232/RS-422*	
closed	open	closed	CCM Peer Current Loop**	
open	closed	closed	RTU Slave RS-232/RS-422	
closed	closed	closed	RTU Slave Current Loop**	
7	8	<u>Parity Selection</u>		
open	open	No parity		
closed	open	No parity		
open*	closed*	Odd parity*		
closed	closed	Even parity		

* Indicates the factory-set default position.

** Maximum data rate for current loop operation is 4800 bps.

GEK-90824D

Table 8. Configuration Switches for Port 2 (Bank B)

SWITCH		FUNCTION	
1	2		<u>Data Rate Selection</u>
open	open		300 bps
closed	open		1200 bps
open	closed		9600 bps
closed*	closed*		19.2 Kbps*
3	4	5	<u>Protocol Selection</u>
open	open	open	CCM Master RS-232
closed	open	open	CCM Master RS-422
open	closed	open	CCM Slave RS-232
closed	closed	open	CCM Slave RS-422
open*	open*	closed*	CCM Peer RS-232
closed	open	closed	CCM Peer RS-422
open	closed	closed	RTU Slave RS-232
closed	closed	closed	RTU Slave RS-422
6			<u>Turn-Around Delay for CCM and RTU</u>
open*			0 ms*
closed			500 ms
7			<u>Parity Selection</u>
open			No Parity
closed*			Odd Parity*
8			<u>Module Operation</u>
open*			Execute I/O CCM operational software*
closed			Execute factory test software
			<u>Reset Switch</u>
open*			I/O CCM module is enabled*
closed			I/O CCM module is reset

* Factory-set default position.

Table 9. Configuration Switches for Port 1 (Bank C)

SWITCH	FUNCTION
1	<u>RS-232 Operation</u>
open	Disconnects Pins 15, 16 for Port 1 RS-232
* closed	Connects Pins 15 and 16 for Port RS-232 operation (use external jumper if desired across pins 15-16).

* Factory-set default position,

Inserting the I/O CCM in its Slot

Use the extraction/insertion tool to remove or install the module in the Series Six CPU rack, I/O slot, or Series Sk Plus rack.

Guide the faceplate over the circuit board so that proper contact is made. Then secure the faceplate to the rack using the thumbscrews at the top and the bottom of the faceplate.

Power may **now** be applied to the module and other external devices may be connected to either of the ports. After power up diagnostics, the indicator lights should all turn ON.

Programming the I/O CCM

There are two methods of generating window communications between the I/O CCM and the CPU.

- DPREQ Windows
- DPU Executive Windows

NOTE

The DPU Executive Window method of communication may be used with the following versions (or later) Series Six Logic Control Function cards : IC600CB525 for Advanced, IC600CB526 for Expanded, and IC600CB515 Expanded II.

Earlier Logic Control Function cards (CB502 for Advanced, CB512 for Expanded) require that a DPREQ be programmed to communicate with the I/O CCM, and the CPU must be set to RUN mode.

Programming the DPREQ

The ladder logic program grants communication windows to the I/O CCM through the programmed DPREQ or WINDOW instruction. The ladder logic

programs initiate serial data transfers to another device by loading a command into the I/O CCM command registers.

Program the DPREQ or WINDOW instruction to establish windows between the I/O CCM and the CPU. The WINDOW instruction is valid for CPU microcode Version 130 or thereafter.

Program the registers containing the communications command and parameters for the required transfer of data if the I/O CCM is to initiate communications.

Establishing I/O CCM to CPU Communications Windows

The CPU provides a window to the I/O CCM using the DPREQ instruction (or WINDOW instruction) as shown below. When properly entered, the CPU COMM LED will start blinking to indicate that windows are occurring.

Example ladder logic rung for programming the DPREQ instruction.



In this program, the I/O CCM will receive a CPU communications window if output Oxxxx is on. The contents of register Rnnnn must correspond to the first I/O point address of the I/O CCM plus 1000 decimal. If the I/O CCM address is for inputs 1-8, then HHHH equals 03E9H (decimal 1001).

When the I/O CCM services the CPU communications window without fault, output Oyyyy will remain off. If a fault occurs during the CPU communication window, Oyyyy will turn on.

The I/O CCM does not process serial transfers until the first window is received after the module has powered up. The module needs the first window to

GEK-90824D

determine the CPU ID number and the CPU register and user **logic** size.

a42720

The CPU COMM LED blink rate will show the frequency of DPREQ windows. The LED blinking means that the module detects that the window opened and closed successfully. (The module may or may not transfer data during that window).

The frequency of DPREQ windows to the I/O CCM module affects the performance (time to complete a message) of the serial links. Therefore, the user should guarantee that the module receives windows on a regular basis. For the fastest response times on the serial link, the module can be given a window once per scan or even multiple windows per scan.

The I/O CCM has a 5-second timeout on waiting for a window to transfer data to or from the Series Six CPU. If the timeout occurs, the I/O CCM will abort the serial link (sends EOT or an error response).

Running at the DPU Executive Window

With the enhanced I/O CCM (Version 203 Hex, or thereafter), it is possible to get windows with the CPU without having a DPREQ in the ladder logic. This feature allows windows to continue while the CPU is stopped.

NOTE

You must have CPU microcode version V107 Advanced, VI18 Expanded, V130 Expanded II (or later versions) for windows to continue while the CPU is stopped.

The following steps are required to set-up the I/O CCM to run at the DPU address.

- Power-down the unit.

Set the backplane DIP switch for Inputs 1009-1016 to be addressed (7E hexadecimal).

Refer to Figure 4 for switch configuration (Switch 1 CLOSED, all other switches OPEN).

Connect the I/O terminator plug. Refer to Tables 10 and 11, for the I/O Terminator Plug wiring.

- Power-up the unit.

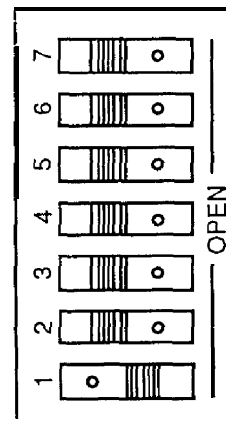

Figure 4. Backplane Switch Setting for Running at DPU Window

I/O Terminator Plug (DPU)

A special I/O terminator plug may be required when operating the I/O CCM module at the DPU Executive Window. The I/O Terminator Plug requirement is dependent upon: whether the I/O CCM is placed in a CPU rack or an I/O rack, and whether the I/O Controller card installed in the CPU rack is type IO14 or IO15.

Installing the I/O CCM in a CPU Rack: When the I/O CCM is installed in a CPU rack (e.g., Series Six Plus or Series 60 PLC) along with the IO14 card, the I/O terminator plug (wired as Table 10) must be used.

Table 10. I/O Terminator Wiring (CPU Rack)

PIN	SIGNAL	JUMPER
30	FIN+	Pins: 30, 35, 37
35	DPE+	
37	GND	
31	FIN-	Pins: 31, 34, 36
34	+5v	
36	DPE-	

Position the 37-pin, male connector plug on the I/O port of the I/O Controller (IO14) card in the Series Six CPU -- Slot 1.

Installing the I/O CCM in an I/O Rack: When the I/O CCM is installed in an I/O rack along with the IO14 card in the CPU rack, the I/O cable must be modified at the connector going to the CPU rack.

Verify that the CPU connector end of the I/O cable is wired as shown in Table 11.

Also, a jumper setting for the 1014 card is required -- Locate Jumper ABC in A-B position.

Table 11. Connector Modification (I/O Rack)

PIN	SIGNAL	JUMPER
34 36	+5v DPE-	Pins: 34, 36
35 37	DPE+ GND	Pins: 35, 37

Installing the I/O CCM with I/O Controller (IO15): When the I/O CCM is installed in either a CPU rack or I/O rack along with the I/O Controller (IO15) card, the I/O terminator plug is NOT required.

Position the 1015 card jumper (Jumper ABCK) in A-K position.

Programming the Communications Command and Parameter Registers

Each I/O CCM has an associated communications command register. This register is monitored by the I/O CCM for communication commands which the user program wants to initiate. The command register corresponds to the first input point of the address of the module.

For example, if the I/O CCM is addressed (using the backplane DIP switches) at inputs 9-16, then the communications command **register in the Series Six CPU** is register 9.

The format of these commands and the command parameters is the same as for the CCM2 and CCM3. The main difference is that for the I/O CCM, the command register reference must always correspond to the module address.

Therefore, the reference for the DPREQ register must not be the same as the command register reference.

When the user sets up one of these commands for execution, the I/O CCM will read the communications command number and the command parameters. It will then zero the communications command register to notify the user that the command was read by the I/O CCM. The I/O CCM status byte indicates when the command is in progress and when the command has completed.

The module is addressed for I/O points 1-8 (01001 dec or 03E9 hex). The CPU communications window is opened once each scan. The example below shows the logic necessary to initiate a serial request using the BLOCK MOVE function in the Series Six CPU.

Refer to GEK-25364, Series Six PLC Data Communications Manual for definitions of the command and parameter registers, and for programming examples.

```

Command Register      Command Parameters
-----
R0001
-1 E--
xxxx  nnnn  nnnn  nnnn  nnnn  nnnn  nnnn  0000
      (Rn) (Rn+1) (Rn+2) (Rn+3) (Rn+4) (Rn+5)
                                BLOCK MOVE ]+- ( )
                                Open Communication Window

CONST      R0200      R0200
-[  A      MOVE      B      ]+[DPREQ]
  01001      01001      03E9
    
```

I/O CCM Status Byte

DPREQ Windows: The eight input points in the Series Six CPU which correspond to the address of

the I/O CCM Module are used to provide the CPU with the status of the module.

DPU Executive Windows: When the I/O CCM is running at the DPU executive window the status

GEK-90824D

address is IO993 - 11000. In this way, the I/O CCM status byte will not be in conflict with the CCM2/3 status byte.

The I/O CCM status byte is updated in the same way as the CCM2 and CCM3 status bytes. The module guarantees that the pulsed status bits will be pulsed a minimum of three windows.

DPREQ and DPU: The I/O CCM status byte has the same format as the CCM2 and CCM.3 status bytes. See GEK-25364 for the status byte format.

Port Characteristics and Wiring Diagrams

Table 12. Pinouts of the Port Connectors

PIN	COMMUNICATIONS PORT (J1)	COMMUNICATIONS PORT (J2)
1	NC	NC
2	Data Out RS-232	Data Out RS-232
3	Data In RS-232	Data In RS-232
4	NC	RTS (RS-232)
5	NC	CTS (RS-232)
6	NC	NC
7	Ground	Ground
8	Data Out (+) Current Loop	NC
9	Ground	Ground
10#	Data Out (+) RS-422	Data Out (+) RS-422
11	Data In (+) RS-422	Data In (+) RS-422
12	Current Source (+) Rxd	NC
13	Current Source (+) Txd	NC
14	NC	Output Relay - Normally Closed
15+	RS-232 JMP 1	Output Relay - Normally Open
16+	RS-232 JMP 2	Output Relay - Common
17	Terminate Rxd RS-422	Terminate Rxd RS-422
18	Data In (+) Current Loop	NC
19	Data In (-) Current Loop	NC
20	NC	NC
21	Data Out (-) Current Loop	NC
22#	Data Out (-) RS-422	Data Out (-) RS-422
23	Data In (-) RS-422	Data In (-) RS-422
24	Current Source (-) Rxd	NC
25	Current Source (-) Txd	NC

+ Optional connection for Port 1 only, switch in DIP bank C can be set to make this connection,
 # RS-422 transmit signals for communications port J2 only are tristated for multi drop links when the transmitter is inactive.

The following diagrams include the basic configurations. For more information on RS-232 and RS-422 connections and for connections to the CCM2 or CCM3 refer to GEK-25364 Series Six PLC Data Communications Manual.

Cable Configuration

Cable wiring for the I/O CCM will vary depending upon the desired configuration. A few of the more common applications are shown in the following figures.

General guidelines for cable construction are as follows:

At short distances (under 1000 feet) almost any twisted shielded pair will work. The specified cables will provide reliable operation at data rates up to 19.2 Kbps and distances up to 4000 feet.

Good wiring practices must be observed. Twisted pairs must be matched (i.e., one pair is transmit, the other pair is receive.)

When routing communication cables outdoors transient suppression devices should be used to reduce the possibility of damage due to lightning or static discharge. Best results have been obtained with General Semiconductor Industries Transzorb SA series wired from each signal line to earth ground at both ends of the cable.

RS-232 Cables

a40523

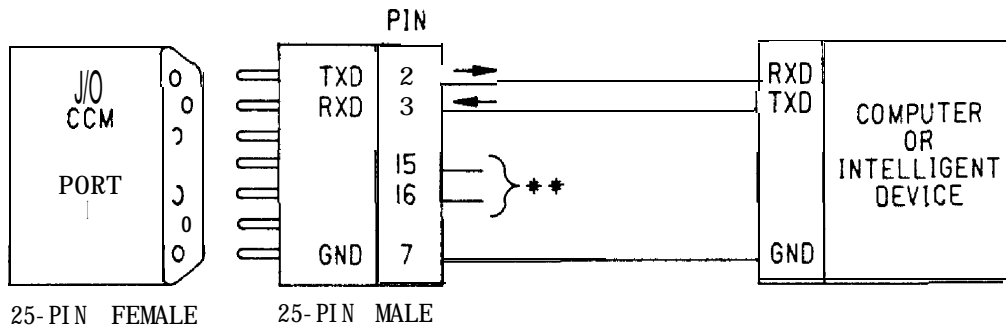

** PINS 15 AND 16 MUST BE CONNECTED ON PORT1. THIS MAY BE DONE ON THE CONNECTOR, ON THE CABLE, OR VIA THE DIP SWITCH C SETTING.

Figure 5. RS-232 Point-to-Point Wiring (Port 1)

a40524

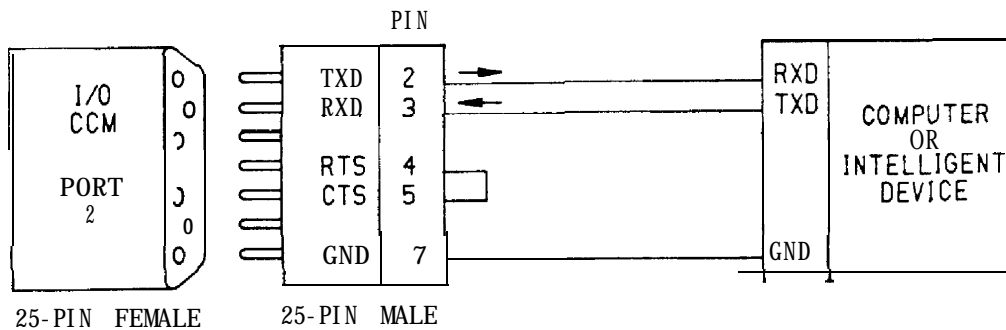

Figure 6. RS-232 Point-to-Point Wiring (Port 2)

GEK-90824D

RS-422 Cables

a40525

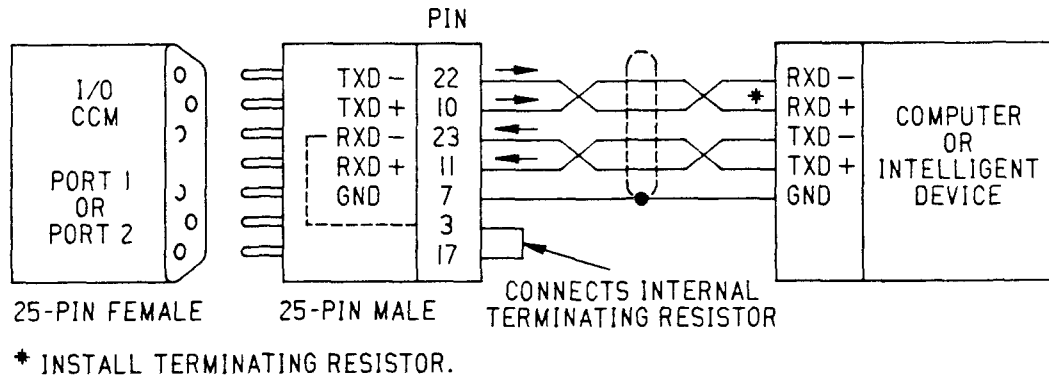
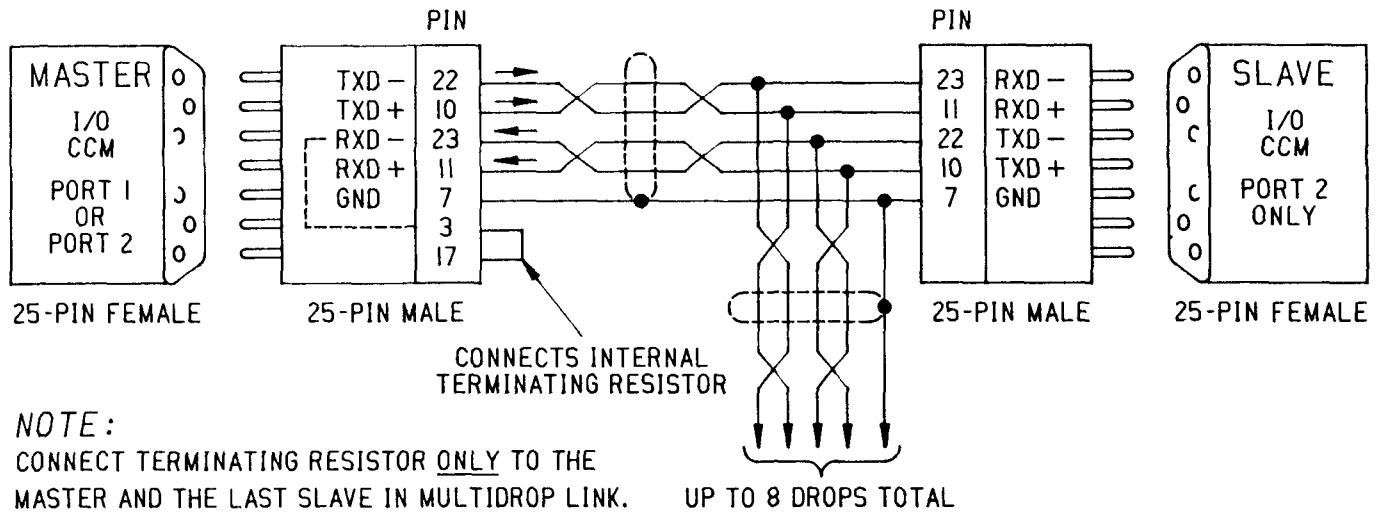

Figure 7. RS-422 Point-to-Point Wiring

a40526



NOTE:

CONNECT TERMINATING RESISTOR ONLY TO THE MASTER AND THE LAST SLAVE IN MULTIDROP LINK.

Figure 8. RS-422 Multidrop Wiring

Convention for RS-422 Direct Cable Diagrams

The RS-422 signal nomenclature used in this data sheet are cross referenced to the RS-422 EIA standard as follows:

CCM SIGNAL NAME	RS-422 STANDARD SIGNAL NAME
RS-422 out + (TXD+)	B
RS-422 out - (TXD-)	A
RS-422 in + (RXD+)	B'
RS-422 IN - (RXD-)	A'

During a mark condition (logic 1), B will be positive with respect to A.

During a space condition (logic 0), B will be negative with respect to A.

a40529

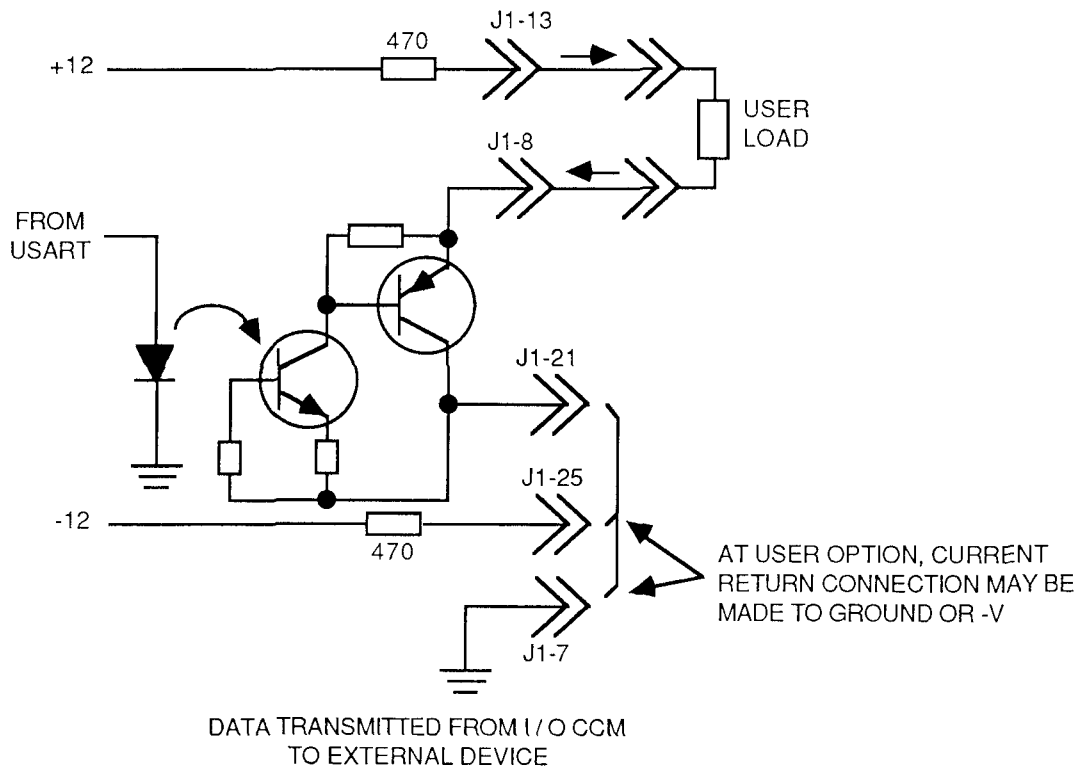

Figure 9. Active Current Loop Data Transmit

a42439

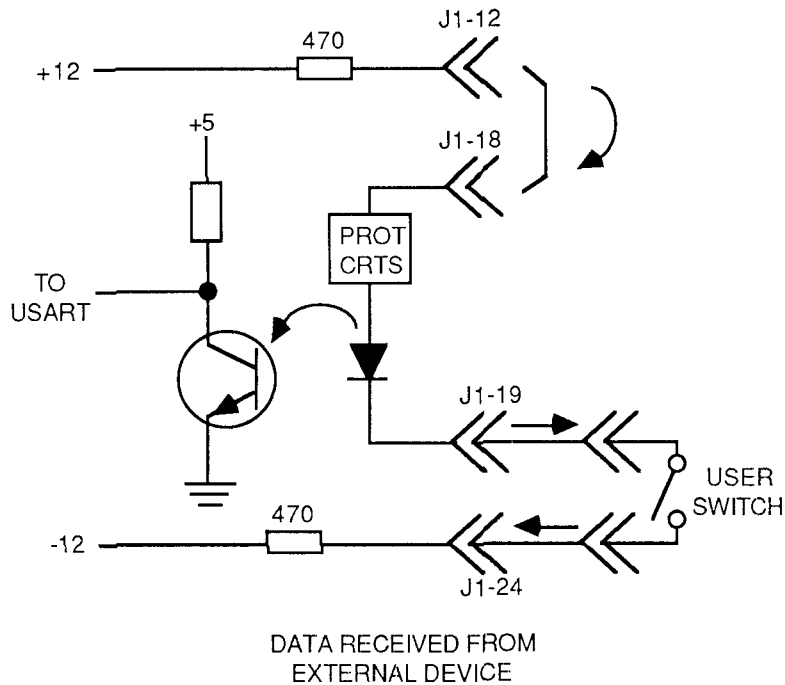

Figure 10. Active Current Loop Data Receive

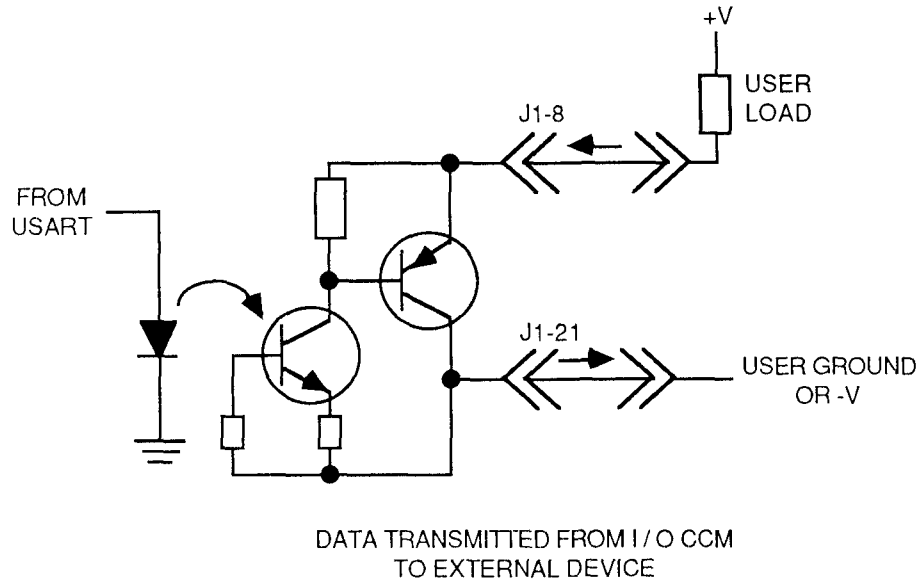

Figure 11. Passive Current Loop Data Transmit

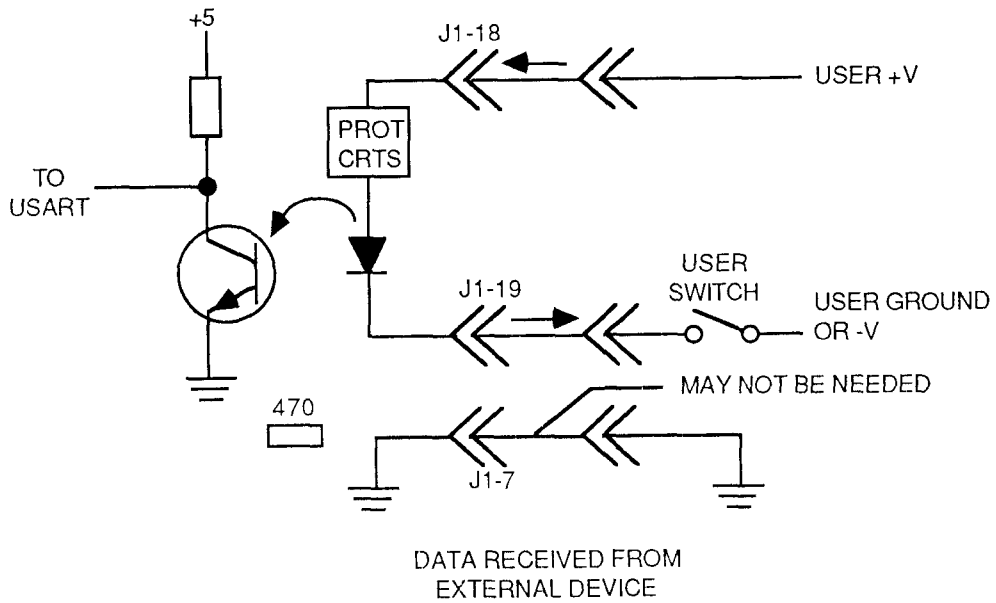

Figure 12. Passive Current Loop Data Receive

I/O CCM Notes for Users Familiar with CCM2/3

1. An external device can perform program uploads and downloads using the enhanced I/O CCM module firmware.

With the X/O CCM module firmware (Version 203 Hex, or later) uploads and downloads may be performed using either the Advanced, the Expanded or the Expanded II, CCU5. Refer to Table 14, Ordering Information.

2. The user is not restricted from executing CCM protocol functions to write to memory areas which might stop the Series Six CPU (i.e., subroutine vector addresses and User Logic). This could result in error conditions in the I/O CCM. The I/O CCM receives windows from the CPU only if the CPU is running when the I/O CCM does not use the DPU executive window.
3. The software version number as read from Diagnostic Status Word 12 for the I/O CCM will start with 512 (200H) and increment by one (1) for each revision thereafter. This relates to the CCM2 and CCM3 as follows:

Board	Diagnostic Status Word 12 Software Version # Range
CCM2	1 - 255 (1 - 0FFH)
CCM3	256 - 511 (100H - IFFH)
I/O CCM	512 - 767 (200H - 2FFH)

4. When a serial protocol error occurs when using the CCM protocol on the I/O CCM, both the Txd

and Rxd LEDs for the associated port will go out. When the next successful message is sent or received, the LEDs will turn on again. The Rxd and Txd LEDs will reflect the reception and transmission of characters.

5. The I/O CCM cannot be configured from registers.
6. The I/O CCM does not perform tape or OIU operations
7. The I/O CCM does not use a battery.
8. The port 2 relay and RTS are turned on before all serial transmissions on Port 2. The port 2 relay can be heard opening and closing when communications are occurring on port 2; this is normal.
9. The RTU protocol can be selected to use the 500 msec turn-around delay on the J2 port.
10. The I/O CCM module will check for commands (in the communications command register) between communications with serial devices and continually when idle.
11. The maximum data rate for current loop operation is 4800 bps.

NOTE

If commands are not going to be initiated from the I/O CCM, a value of zero should be placed in the command register. The five successive command parameter registers can then be used as desired.

GEK-90824D

Table 13, Module Specifications

<p>Space Requirements:</p> <p>Power Requirements:</p> <p>Storage Temperature:</p> <p>Operating Temperature:</p> <p>Humidity:</p> <p>Altitude:</p> <p>Isolation:</p> <p>Noise & Transient:</p> <p>Immunity:</p>	<p>One I/O slot in either a Series Six CPU rack, Series Six Plus CPU rack, or a High-Capacity I/O rack</p> <p>+5 Vdc requirement is 1.5A or 20 units of load +12 Vdc requirement is 300 mA or 12 units of load (supplied by rack power)</p> <p>0 to 70 C</p> <p>0 to 60 C</p> <p>5% - 95% (non-condensing)</p> <p>Up to 6,600 feet (2,000 meters) above sea level (operating)</p> <p>(Port to Port and either Port to Series Six common), Transient: 1500 Vac, 50/60 Hz for 1 minute maximum, non repetitive.</p> <p>Continuous: 240 Vdc or RMS ac, 50/60 Hz.</p> <p>Meets following specifications Showering arcs per NEMA ICS 2,230.40 Surges per ANSI C37.90.9 5 W R.F. transmitter 27-450 MHz</p>
---	---

Table 14. Ordering Information

DESCRIPTION	CATALOG NUMBER
Circuit Board & Faceplate (I/O CCM)	IC600BF948
Advanced CCU5	IC600CB525
Expanded CCU5	IC600CB5526
Expanded II CCU5	IC600CB515
Faceplate	IC600FP948

For further information, contact your local GE Fanuc Automation - NA sales representative.