



SERIES SIX PROGRAMMABLE CONTROLLERS

GEK-84867

Types: J, K +, S, T, B, E, R

THERMOCOUPLE INPUT MODULES

GENERAL DESCRIPTION

The Thermocouple Input modules provide eight, electrically-isolated inputs for the detection of low-level, analog signals developed by thermocouple devices. These modules are available in seven versions: Type J, Type K+, Type S, Type T, Type B, Type E, and Type R. The features and benefits of the Thermocouple Input modules are summarized in Table 1.

The modules contain two, four-channel, thermocouple conditioners; either four-channel conditioner can be reassigned for use with any of the seven thermocouple types (J, K+, S, T, B, E, or R). The low-level input signal conditioning includes $\pm 1000V$ DC, isolation, high common mode rejection, filtering and low drift amplification. Signal integrity is further preserved by a high-accuracy programmable-gain amplifier and a 13-bit integrating A/D converter.

The output of this converter constitutes a 13-bit word (12 bits plus sign) equivalent to ± 4096 counts of resolution.

An on-board microprocessor then scales, linearizes and converts the input data to either degrees centigrade or Fahrenheit.

The temperature value is sent, along with binary information giving various status conditions and the channel number, to the Input Status Table in the Series Six CPU. Temperature values transferred to the Series Six CPU can be in either sign magnitude or 2's complement format, as jumper-selected by the user.

The input channels are sampled at a rate of 15 or 30 readings per second (for 60 Hz settings). The factory-set sample rate of 15 samples per second gives a Normal Mode Rejection (NMR) of 86 dB for each input. (NMR indicates immunity to power-line frequency noise added to the low-level input signals.) Where NMR is of lesser importance, the sample rate can be doubled, to 30 samples per second.

An external Cold-Junction Compensation element, which connects directly to the terminals on the module faceplate, eliminates the need for an ice-point reference function.

Refer to Figure 1 (next page) for Thermocouple Input module specifications.

TABLE 1. FEATURES AND BENEFITS

FEATURES	BENEFITS
Seven types available: Type J Thermocouple Type B Thermocouple Type K Thermocouple Type E Thermocouple Type S Thermocouple Type R Thermocouple Type T Thermocouple	Useful in variety of applications
Eight isolated inputs per module	Low cost per input point
Contains cold-junction compensation and linearization routines	Direct interface to thermocouple devices
Thirteen-bit resolution	High conversion accuracy (1 part in 8192)
Temperature readings in degrees C or F	Ease of operation
Open thermocouple detection	Simplifies troubleshooting
APPLICATIONS	
* Injection Molding	* Chemical Processing
** Annealing Furnaces	

<p>Power Requirements: 5V DC, 1.7 A maximum (Supplied by I/O Rack power supply)</p> <p>Input Requirements: J: -4.632 to +42.922 MV K+: -3.553 to +54.845 MV S: +2.323 to + 18.698 MV T: -5.603 to +20.869 MV B: +2.782 to + 13.814 MV E: -8.824 to +76.358 MV R: 0.000 to +21.105 MV</p> <p>Normal Mode Rejection: 86 dB at line frequencies: @ 15 sample/sec; @ 12.5 sample/sec.</p>	<p>Resolution: 13 bits (± 4096)</p> <p>Input to Series Six Isolation 1000V peak AC or DC</p> <p>Low Pass Filter; High Noise Rejection</p> <p>Operating Temperature: 0” to 60°C (32” to 140°F) (at outside of rack)</p> <p>Storage Temperature: -20” to +80°C (-4” to + 176°F)</p> <p>Humidity: 5% - 95% (non-condensing)</p>
---	---

Thermocouple Temperature Range and Module Accuracy*		
Type	°C	°F
J	-100 to 760°C ± 1.3”	-148 to 1400°F ± 2.34”
K+	-0 to 1371°C ± 1.4”	+32 to 2500°F ± 2.52”
S	300 to 1768°C ± 3.5”	572 to 3214°F ± 6.3”
T	-200 to 400°C ± 1.3”	-328 to 752°F ± 2.34”
B	750 to 1820°C ± 3.0°	1382 to 3308 ± 5.4”
E	-200 to 1000°C ± 3.0°	-328 to 1832 ± 5.4”
R	0 to 1768°C ± 4.2°	32 to 3214 ± 7.5”

*NOTE: Total accuracy should also include accuracy of thermocouple wire. typically, ± 1 or 2 °C or 0.75%, whichever is greater.

Module Drift* (Allow 15 minutes of operation for specified accuracy)		
Type	Temp. Drift	Time Drift
J	± .1°C/°C	± .10°C/Month
K+	± .3°C/°C	± .15°C/Month
S	± .3°C/°C	± .15°C/Month
T	± .1°C/°C	± .10°C/Month
B	± .3°C/°C	± .15°C/Month
E	± .3°C/°C	± .15°C/Month
R	± .3°C/°C	± .15°C/Month

*NOTE: These specifications describe worst case variations in accuracy of Thermocouple Input module temperature readings (established at time and temperature of calibration) resulting from changes in ambient temperature per degrees centi-grade and progression of time in months.

FIGURE 1. SPECIFICATIONS

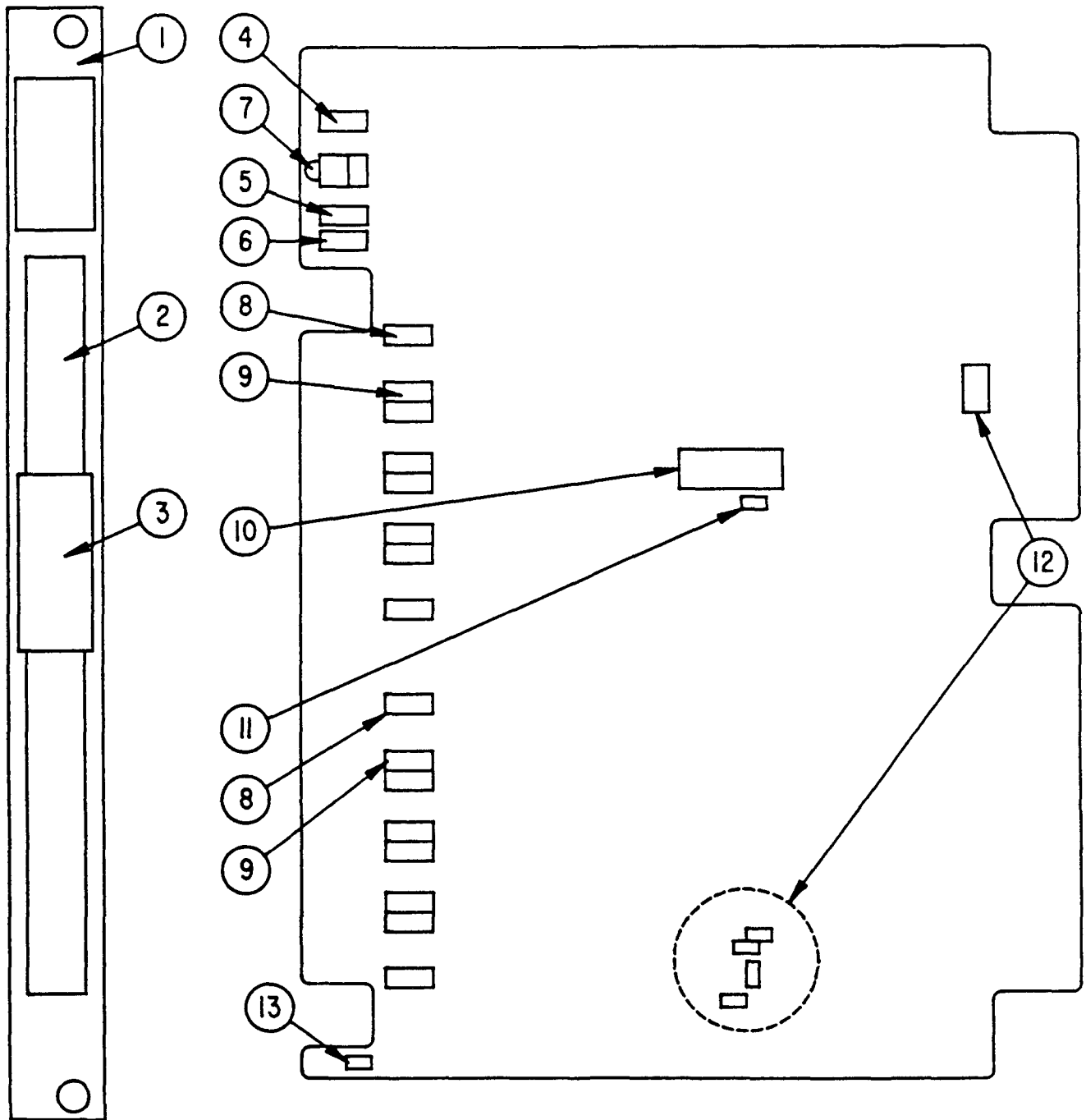

FIGURE 2. USER ITEMS (Part 1 of 2)

- ① Faceplate
- ② User Connector Block
- ③ Cold Junction Compensation Element
- ④ A/D Reference ADJ Refer to Calibration section.
- ⑤ Output Offset ADJ (Ch 5-8).
- ⑥ Output Offset ADJ (Ch 1-4).
- ⑦ Board OK LED:
 - OFF: If module has failed board diagnostics
 - ON: No module-level errors detected by board diagnostics
- ⑧ Offset ADJ Pots 1-8: Adjust voltage offsets for circuits 1-8, respectively. (Refer to Calibration section.)
- ⑨ GAIN ADJ Pots 1-8: Adjust voltage gains for inputs 1-8, respectively. (Refer to Calibration section.)
- ⑩ Configuration DIP switch: (Refer to the following chart).

DIP SWITCH								
(<input type="checkbox"/> Contains Rocker Switch Number)								
Function	Group 1 (Inputs 1-4)			Group 2 (Inputs 5-8)				
	①	②	③	④	⑤	⑥	⑦	⑧
Type J T/C	ON	ON	ON	ON	ON	ON	—	—
Type K + T/C	OFF	OFF	OFF	OFF	OFF	OFF	—	—
Type S T/C	ON	OFF	ON	ON	OFF	ON	—	—
Type T T/C	OFF	OFF	ON	OFF	OFF	ON	—	—
Type B	ON	OFF	OFF	ON	OFF	OFF	—	—
Type E	ON	ON	OFF	ON	ON	OFF	—	—
Type R	OFF	ON	OFF	OFF	ON	OFF	—	—
4-Channels (1-4)	—	—	—	—	—	—	ON	—
8-Channels (1-8)	—	—	—	—	—	—	OFF	—
°C	—	—	—	—	—	—	—	ON
°F	—	—	—	—	—	—	—	OFF

⑪ Data Format Jumper

Function	Jumper Setting
Sign Magnitude	57-58
2's Complement	56-57

⑬ RUN/Calibrate Jumper

Function	Jumper Setting
RUN	1 - 2
Calibrate	2 - 3

⑫ Sample Rate Jumpers: The factory-set sample rate provides Normal Mode Rejection (NMR) of 86dB at either 50 or 60 Hz line frequencies where NMR is of lesser importance, the sample rate can be increased.

LINE FREQUENCY	SAMPLE/ SEC	JUMPERS
50 Hz	12.5	43-44, 45-46 50-51, 69-70
	25	43-44, 46-47 49-51, 68-69
60 Hz	15	42-43, 45-46 48-50, 51-52 69-70
	30	42-43, 46-47 48-49, 51-52 68-69

FIGURE 2. USER ITEMS (Part 2 of 2)

INSTALLATION

The Thermocouple Input module can be installed in an I/O rack or in a Model 60 CPU rack. Before installing this module, set the dual-in-line-package (DIP) switches immediately behind the card slot on the rack backplane to reserve a group of 32 consecutive bits in the appropriate Input Status Table of the CPU. For specific DIP switch settings, refer to Figure 3.

Use the extraction/insertion tool furnished with the Series Six CPU to remove or install the circuit board. With the board in place in the rack, guide the faceplate over the circuit board so that proper contact is made.

Then, secure the faceplate to the rack using the thumb-screws at the top and bottom.

Refer to Figure 4 (next page, left side) for typical user input connections. The connections to channel 1 (+1, -1) indicate a floating thermocouple; the connections to channel 2 (+2, -2) indicate a grounded thermocouple. Either connection can be used on any of the eight channels. Shielded wire may not be required for short distances. CJ1 through CJ4 are terminals for the Cold Junction Compensation Element. Table 2 (below) provides ANSI standard color codes and thermocouple polarities.

INPUT NUMBER	DIP SWITCH POSITION					INPUT NUMBER	DIP SWITCH POSITION					INPUT NUMBER	DIP SWITCH POSITION				
	7	6	5	4	3		7	6	5	4	3		7	6	5	4	3
1- 32						353-384	X	X	X	X	705-736	X	X	X			
33- 64				X		385-416	X	X			737-768	X	X	X	X		
65- 96			X			417-448	X	X	X		769-800	X	X				
97-128			X	X		449-480	X	X	X		801-832	X	X		X		
129-160		X				481-512	X	X	X	X	833-864	X	X	X			
161-192		X	X			513-544	X				865-896	X	X	X	X		
193-224		X	X			545-576	X			X	897-928	X	X	X			
225-256		X	X	X		577-608	X		X		929-960	X	X	X	X		
257-288	X					609-640	X		X	X	961-992	X	X	X	X		
289-320	X			X		641-672	X	X			993-1024 } (NOT USED)	X	X	X	X		
321-352	X	X			673-704	X	X	X									

X = Switch in OPEN Position (Depressed to the Left)
 Switches No. 1 and No. 2 should be in CLOSED Position

FIGURE 3. DIP SWITCH SETTINGS

TABLE 2. THERMOCOUPLE POLARITIES

THERMOCOUPLE TYPE	MATERIAL	POLARITY	ANSI COLOR CODE
J	Iron Constantan	+	White
		-	Red
K+	Chromel Alumel	+	Yellow
		-	Red
S	Platinum/10% Rhodium Platinum	+	Black
		-	Red
T	Copper Constantan	+	Blue
		-	Red
B	Platinum/30% Rhodium Platinum/6% Rhodium	+	Gray
		-	Red
E	Chromel Constantan	+	Purple
		-	Red
R	Platinum/13% Rhodium Platinum	+	Black
		-	Red

CALIBRATION PROCEDURE

Required equipment:

- Voltmeter 4 digit
- Voltage source - resolution to 1 mv.
- Calibration connector (IC600MA508A)

Calibration of the Thermocouple Module should be performed every six months. For maximum accuracy the card should be calibrated at the normal ambient temperature which occurs in operation. Allow the thermocouple card to warm up for one hour before calibration.

1. Loosen the thumbscrews and remove the faceplate, taking care not to disturb the field wiring. Move the RUN/CAL jumper to the calibrate position (2 to 3). Refer to Figure 2, User Item No. 13. Place the calibration connector (P/N IC600MA508A) on the thermocouple board.
2. A/D Reference trim, (Refer to Figure 4, right side.) Place the (+) lead of the voltmeter on TP2 and the (-) lead on TP3. Adjust the A/D reference potentiometer to obtain a voltmeter reading of 2.048 volts.
3. Offset trim. In Figure 4, the offset adjustment potentiometers for channels 1 to 8 are labeled Offset 1 to Offset 8, respectively.

Gain trim. In Figure 4, the gain adjustment potentiometers for channels 1 to 8 are labeled Gain 1 to Gain 8, respectively.

For each channel (1-8) adjust the offset potentiometer, then the gain potentiometer, as follows:

- a. Connect the (+) lead of the voltmeter to TP1 and the (-) lead of the voltmeter to TP3.
 - b. Connect the (+) and (-) leads of the voltage source to the (+) and (-) inputs, respectively, of the channel to be calibrated.
 - c. Set the voltage source to 0.000 volts.
 - d. Adjust the appropriate offset potentiometer to obtain a reading of 0.000 volts on the voltmeter.
 - e. If the thermocouple card is type J or K, set the voltage source to 0.050 volts; if the card is type S, T, B, or R, set the voltage source to 0.025 volts; if the card is type E or K+, set the voltage source to 0.100 volts.
 - f. Adjust the appropriate gain potentiometer to obtain a reading of 4.000 volts on the voltmeter.
4. Remove the calibration connector. Place the RUN/CAL jumper in the run position (1 to 2). Refer to Figure 2, User Item No. 13. Replace the faceplate, taking care not to disturb field wiring.
 5. Mark the calibration date on the faceplate lens in the space provided.

ORDERING INFORMATION *

Module	Circuit Board and Faceplate	Circuit Board Only	Faceplate
Type J	IC600BF813A	IC600YB813B	*IC600FP813A
Type K+	IC600BF814A	IC600YB814B	*IC600FP813A
Type S	IC600BF815A	IC600YB815B	*IC600FP813A
Type T	IC600BF816A	IC600YB816B	*IC600FP813A
Type B	IC600BF817A	IC600YB817A	*IC600FP813A
Type E	IC600BF818A	IC600Y08-8A	*IC600FP813A
Type R	IC600BF819A	IC600YB819A	*IC600FP813A

Calibration Connector

IC600MA508A

Cold Junction Compensation Element is included with the faceplate assembly IC600FP813A.

CATALOG NUMBER REVISION SUFFIX

The equipment listed above having the catalog numbers shown and the same equipment having a higher alpha suffix is designed for listing by UL for use as auxiliary control devices. The equipment is a direct replacement for equipment having the same catalog number but a lower alpha suffix.

The UL symbol on the nameplate means the product is listed by Underwriters Laboratories Inc. (UL Standard No. 508, Industrial Control Equipment, subsection Electronic Power Conversion Equipment.)

For further information, contact your local GE Fanuc sales office.

GE Fanuc Automation North America, Inc., Charlottesville, Virginia