



Series Six™ PLC Programmable Controllers

GEK-84859B

High Density 10 to 50 V DC Sink Output Module

July, 1989

General Description

The High-Density Sink Output module, with indicating Light-Emitting Diodes (LEDs), can be used in an I/O rack, or in any of the I/O slots in a Series Six Plus Central Processor Unit (CPU), to provide a compact, optically-isolated interface between the backplane I/O bus and field digital circuitry (sink),

Each module provides 32 active low outputs divided into 4 groups, each containing 8 outputs. All 32 outputs (4 groups) are normally updated in the course of one I/O scan. A common return point connects the 32 loads on the High-Density Sink Output module.

The placement of a jumper allows the selection of disabling all outputs during a reset condition or the holding of the last state presented to the outputs even if a reset or failure should occur.

By placement of a second jumper on the module the user can select whether the data received from the CPU is inverted (complemented) or non-inverted before controlling the outputs. Two LED indicators identify the selected modes of operation.

The module is supplied in one form having 32 LED status indicators (one for each output) displaying the state of each output individually. A particular LED will be illuminated whenever it's corresponding output is on.

The High-Density Sink Output module feature's and benefits are summarized in Table 1. Refer to Table 3 for module specifications.

Table 1. Features and Benefits

Features	Benefits
32 source output points per module.	Lowcost per output point. Efficient use of I/O rack space.
Output Indicating lights.	Visual indication at the module of the OFF/ON state of the outputs
Programmable hold last commanded state of outputs.	The last commanded output states are retained throughout a Series Six power-down or system fault so long as the user power is uninterrupted.
Applications	
Interface from CPU to: Lamp Drivers Small Coils Other DC loads (current sink)	Compact I/O Systems

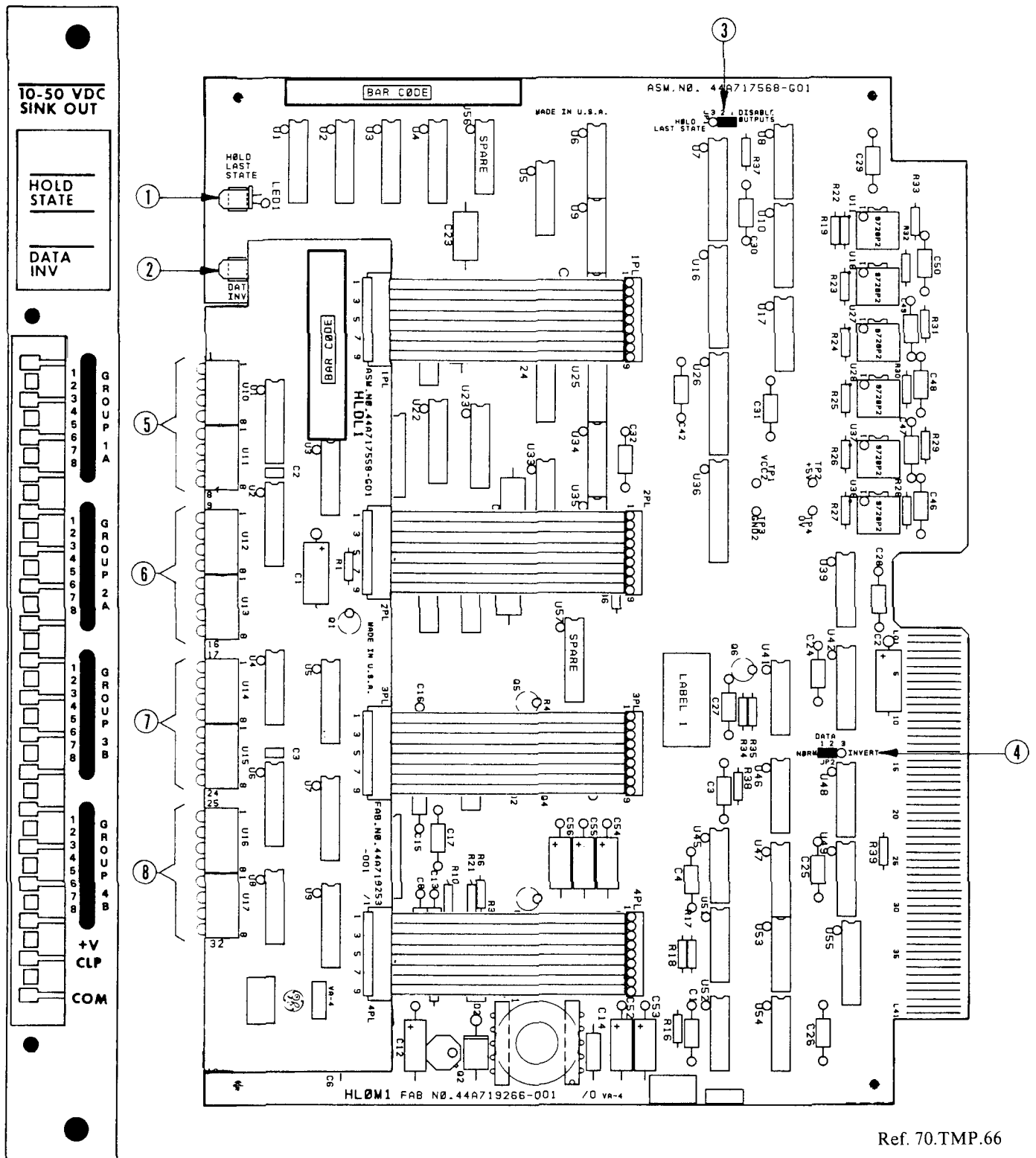

Ref. 70.TMP.66

Figure 1. User Items (Part 1 of 2) High Density 10 to 50 V dc Sink Output Module with Status Indicator Lights

GEK-84859B

- | <p>1. LED Indicator
 ON: Hold Last State
 OFF: Disable Outputs when required</p> <p>2. LED Indicator
 ON: Output Data Inverted
 OFF: Output Data Non-Inverted</p> <p>3. Jumper JP1: 1-2 Position, Disable Outputs
 2-3 Position, Hold Last State</p> <p>4. Jumper JP2: 1-2 Position, Normal
 (1=LOW=ON)
 2-3 Position, Data Inverted
 (1=HIGH=OFF)</p> | <p>LEDs - Illuminated when corresponding output is turned ON (low).</p> <table border="0"> <thead> <tr> <th>Key</th> <th>Group</th> <th>Outputs</th> <th>LED</th> </tr> </thead> <tbody> <tr> <td>5.</td> <td>1</td> <td>1 through 8</td> <td>1 through 8</td> </tr> <tr> <td>6.</td> <td>2</td> <td>1 through 8</td> <td>9 through 16</td> </tr> <tr> <td>7.</td> <td>3</td> <td>1 through 8</td> <td>17 through 24</td> </tr> <tr> <td>8.</td> <td>4</td> <td>1 through 8</td> <td>25 through 32</td> </tr> </tbody> </table> | Key | Group | Outputs | LED | 5. | 1 | 1 through 8 | 1 through 8 | 6. | 2 | 1 through 8 | 9 through 16 | 7. | 3 | 1 through 8 | 17 through 24 | 8. | 4 | 1 through 8 | 25 through 32 |
|--|---|-------------|---------------|---------|-----|----|---|-------------|-------------|----|---|-------------|--------------|----|---|-------------|---------------|----|---|-------------|---------------|
| Key | Group | Outputs | LED | | | | | | | | | | | | | | | | | | |
| 5. | 1 | 1 through 8 | 1 through 8 | | | | | | | | | | | | | | | | | | |
| 6. | 2 | 1 through 8 | 9 through 16 | | | | | | | | | | | | | | | | | | |
| 7. | 3 | 1 through 8 | 17 through 24 | | | | | | | | | | | | | | | | | | |
| 8. | 4 | 1 through 8 | 25 through 32 | | | | | | | | | | | | | | | | | | |

Figure 1. User Items (Part 2 of 2) Cont'd

Table 2. Dip Switch Settings

Output Number	Dip Switch Position					Output Number	Dip Switch Position					Output Number	Dip Switch Position												
	7	6	5	4	3		7	6	5	4	3		7	6	5	4	3								
1- 32						353-384	X		X	X						705-736	X		X	X					
33- 64					X	385-416	X	X								737-768	X		X	X	X				
65- 96				X		417-448	X	X		X						769-800	X	X							
97-128				X	X	449-480	X	X	X							801-832	X	X						X	
129-160			X			481-512	X	X	X	X						833-864	X	X			X				
161-192			X		X	513-544	X									865-896	X	X			X	X			
193-224			X	X		545-576	X				X					897-928	X	X	X						
225-256			X	X	X	577-608	X			X						929-960	X	X	X					X	
257-288		X				609-640	X			X	X					961-992	X	X	X	X					
289-320		X			X	641-672	X	X							993-1024	X X X X X (NOT USED)									
321-352		X		X		673-704	X	X		X															

= Switch in OPEN Position (Depressed to the Left)
 Switches No. 1 and No. 2 should be in CLOSED Position

Installation

The High-Density 10 to 50 volt Sink Output module can be installed in an I/O rack or in a Series Six Plus CPU rack. Before installing the module, the Dual-In-line Package (DIP) switches immediately behind the card slot on the rack backplane should be set to reserve 32 consecutive bits in the appropriate output status table of the CPU. For specific DIP switch settings, refer to Table 2.

The circuit board jumpers must be set to configure the module to operate in the desired system configuration. For example: invert or non-invert and disable outputs or hold last state. Refer to Figure 1 user items.

The response to a power-down or Series Six system fault is defined by jumper 1 (JP1). Position 1-2 (DISABLE OUTPUTS) turns all outputs OFF in such cases. Position 2-3 (HOLD LAST STATE) would maintain the last commanded state of the outputs until new valid data is presented or user power is removed. In either case all outputs are initialized OFF when user power is turned on.

Jumper 2 (JP2) determines what state commanded by the CPU is used to turn an output ON. In the Normal mode (non-inverting) the ON state (active low output) results when a logical 1 is in the Output Status Table.

Conversely, an OFF state (output high) exists with a 0 in the Output Status Table, Just the opposite output state versus output status table exists if the module is placed in the Inverting mode.

When using a High-Density Output module to drive a High-Density Input module, both modules should be configured in the same mode (Inverting or Non-Inverting). Following this procedure ensures that the bit values sent from the Output Status Table to the Input Status Table are not inverted.

It is recommended that the extraction/insertion tool furnished with the CPU be used to remove or install the circuit boards. With the boards in place in the rack, the edge connector on the faceplate should be slipped over the circuit board so that the proper contact is made. The faceplate can then be secured to the rack using the thumbscrews at the top and bottom.

Refer to Figure 2 for a typical symbolic output circuit.

Refer to Figure 3 for typical user connections to this module. If inductive loads are used, the CLP (clamp) terminal should be connected to the positive side of the highest voltage supply used with the loads. For example: if some loads are 12V, some are 24V, and some are 48V, connect CLP to the +48V, even if the 48V loads are only purely resistive.

GEK-84859B

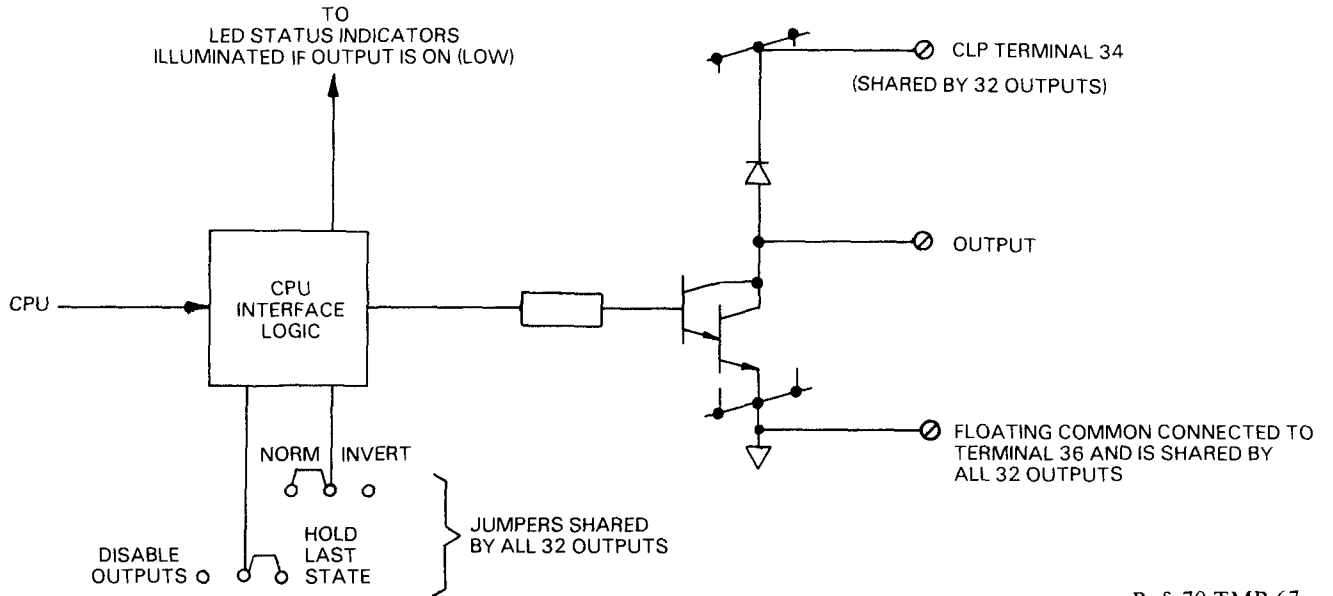

Figure 2. Simplified Symbolic Sink 10 to 50 V DC Output Circuit with Clamp

Ref. 70. TMP.68

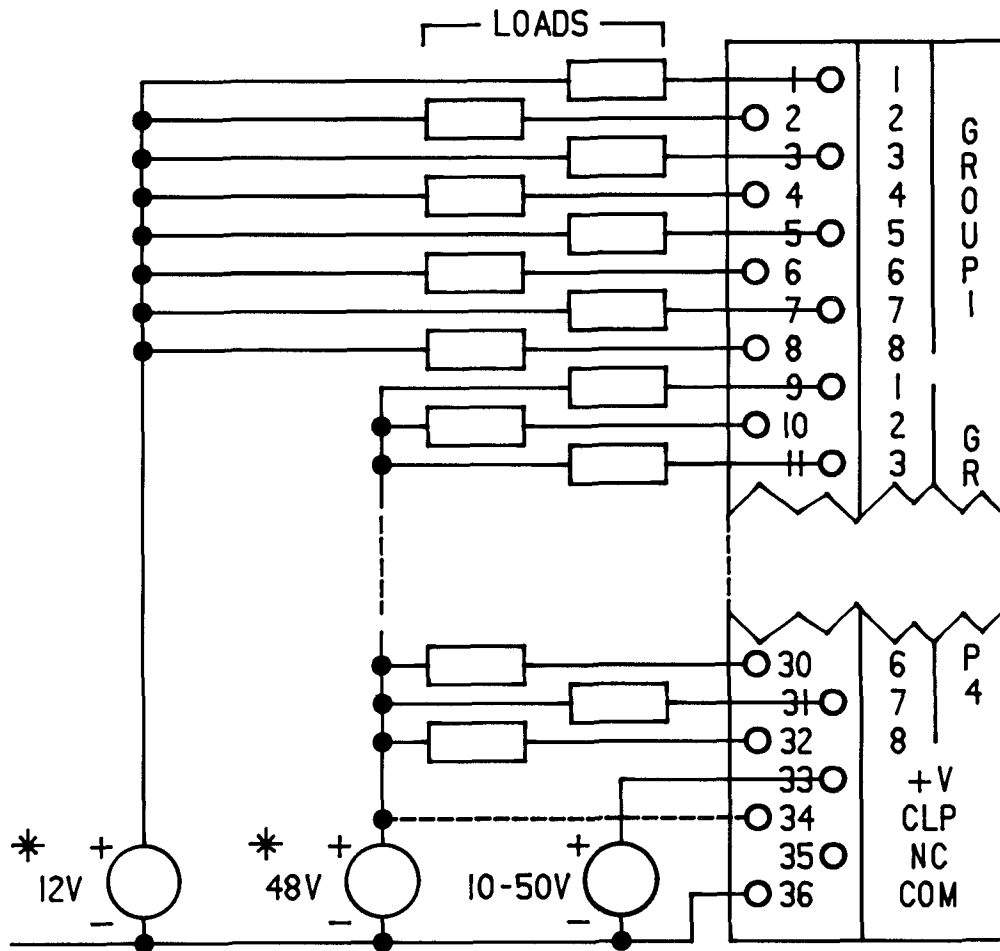

Figure 3. Typical User Output Connections

NOTE

The loads may be connected to any voltage from +10 volts to +50 volts so long as the power supplies share a common negative point. As shown above some loads are connected to +12 volts, and some are connected to +48 volts. Some could be connected to +24V as well or all could have been connected to the same voltage between +10V and +50 volts. For suppression purposes the highest voltage used should also be connected to CLP (terminal 34), as the +48V is shown connected above. Although up to +50 volts may be connected to the +V terminal 33, the lowest voltage present on the module should be connected to terminal 33.

NOTE

For previous revisions of Sink Output modules without indicators (913A and 913B) see GEK-83530.

GEK-84859B

Table 3. Specifications

<p>Dimensions:</p> <p>Storage Temperature:</p> <p>Operating Temperature:</p> <p>Humidity:</p> <p>Altitude:</p> <p>Isolation:</p> <p>Power Requirements:</p> <p>User Supplied Power:</p> <p>Output Capabilities:</p> <p>Response Time:</p>	<p>Circuit Board: 8.15 x 11.0 (inches) 208 x 280 (mm) Faceplate: 12.46 x 1.175 (inches) 317 x 30 (mm)</p> <p>-20° to +80°C</p> <p>0° to 60°C at the outside of rack.</p> <p>5 to 95% (non-condensing)</p> <p>Up to 10,000 feet above sea level (operating).</p> <p>Series Six Plus common to user common, 2000 V dc for one second (maximum). 240 V ac 50/60Hz continuous (maximum). Rate of change (noise immunity) 500 V/microsecond (maximum).</p> <p>Supplied by I/O rack or Series Six Plus rack: +5 V dc, 180 mA maximum or 3 power units. Ref. Chapter 2 section 2, <u>I/O module load, Installation and Maintenance Manual, GEK-25361A.</u></p> <p>To user on module logic at terminal 33. Voltage including ripple: no less than 10 V dc to/or no greater than 50 V dc including ripple of no more than ± 2 v 50/60 Hz. Power Required: 5 Watts with status indicator LEDs.</p> <p>To CLP terminal 34. See note on page 6, Figure 3.</p> <p>ON state, output low: Module acts as a current sink. 250 milliamps maximum 0° to 50°C or 200 milliamps maximum 51° to 60°C. 0.1 milliamps minimum</p> <p>OFF state: Output high: Output floats to load voltage. 1.0 milliamps maximum leakage current.</p> <p>ON to OFF or OFF to ON, 40 microseconds maximum.</p>
---	---

Table 4. Ordering Information

Module	Circuit Board and Faceplate	Circuit Board Only	Faceplate Only
10/50 Vdc Sink Output With Status Indicators	IC600BF923A	IC600BF923A	IC600BF923A

Catalog Number Revision Suffix

The equipment listed above having the catalog numbers shown and the same equipment having a higher alpha suffix is designed for listing by UL for use as auxiliary control devices. The equipment is a direct replacement for equipment having the same catalog number but a lower alpha suffix.

The UL symbol on the nameplate means the product is listed by Underwriters Laboratories Inc.(UL Standard No. 508, Industrial Control Equipment, subsection Electronic Power Conversion Equipment.)

For further information, contact your local GE Fanuc sales office.