



# SERIES SIX

GEK-83546C

## PROGRAMMABLE CONTROLLERS

### HIGH-DENSITY INPUT MODULE WITH STATUS INDICATORS

#### GENERAL DESCRIPTION

The High-Density Input module can be utilized in an I/O Rack, in any of the I/O slots in a Model 60 Central Processor Unit (CPU), or a Series Six Plus CPU to provide a compact, optically-isolated interface between the Series Six backplane I/O bus and Field Digital Circuitry (TTL mode) or input devices (10-50 V mode). The High-Density Input module features and benefits are summarized in Table 1.

This module provides 32 inputs divided into four groups of eight inputs each. All 32 inputs (four groups) are normally updated in the course of one I/O scan.

There is a common ground (or return) point provided for all 32 input points.

By placement of a jumper on the circuit board, the user can select the input data to be sink (active low) or source

(active high). The placement of a second jumper allows the data being sent to the CPU to be inverted (complemented) or non-inverted. Two Light-Emitting Diode (LED) indicators identify the selected modes. A third jumper selects the voltage level of the user power supply: 5 volts or 10 to 50 volts. When operating in the TTL mode, the 5 V power supply must be used. Dual-In-line Package (DIP) switches on the circuit board allow the selection of 50 microsecond or 10 millisecond time delays on an individual basis for each input. Hysteresis of approximately 10% of supply voltage provides better noise immunity even with the filter switched off.

Refer to figure 1 for High-Density Input module specifications.

TABLE 1. FEATURES AND BENEFITS

| FEATURES   | BENEFITS   |
|--|--|
| Three user-selectable input modes:<br>TTL Levels<br>10-50 V dc (sink)<br>10-50 V dc (source)   | Can be used with standard logic circuitry, or sense other DC levels.                           |
| 32 input points per module   | Low cost per input point. More efficient use of I/O-rack space.                                |
| Selectable on-delay and off-delay times of:<br>· 50 microseconds<br>· 10 milliseconds  | Fast response for time-critical applications. Greater filtering for higher noise environments. |
| <b>APPLICATIONS</b><br><br>Interface to CPU from:<br><br>Instruments with TTL outputs<br>Current-sinking DC devices<br>Current-sourcing DC devices<br>Compact I/O system.<br>Example: operator's devices where low cost inputs and high density is required. |  |

|   |                  |                  |                |                       |          |           |            |           |             |             |           |                   |                  |                  |                |                     |                  |                  |                |
|---|------------------|------------------|----------------|-----------------------|----------|-----------|------------|-----------|-------------|-------------|-----------|-------------------|------------------|------------------|----------------|---------------------|------------------|------------------|----------------|
| <p>Dimensions:</p> <p>Circuit Board: 8.15 x 11.0 (inches) 208 x 280 (mm)</p> <p>Faceplate: 12.46 x 1.175 (inches) 317 x 30 (mm)</p> <p>Storage Temperature: -20C to +80C</p> <p>Operating Temperature: 0C to + 60°C at outside of rack.</p> <p>Humidity: 5% to 95% (non-condensing)</p> <p>Altitude: Up to 10,000 feet above sea level (operating)</p> <p>Isolation: Series Six common to user common<br/>2000 V dc for one second (maximum)<br/>240 V ac 50/60Hz continuous (maximum)<br/>Rate of change (noise immunity) 500 V/microsecond (maximum)</p> <p>Power Requirements:<br/>Supplied by I/O rack or Series 60 rack:<br/>+ 5 V dc, 200 mA maximum or 4 power units<br/>Ref. Chapter 2, section 2, I/O module load, <u>Installation and Maintenance Manual, GEK-25361A.</u></p> <p>User supplied power:<br/>TTL Mode: + 5 ± 0.25 V dc including ripple of 0.25 V<br/>Power used by module - 1.5 Watts with LEDs</p> <p>10-50 V Mode: 10 V dc to 50 V dc including ripple.<br/>Ripple &lt; ± 2 volts at 50/60 Hz.<br/>Power used by module - 4.0 Watts with LEDs</p> <p>Input Requirements:</p> <table border="0"> <tr> <td>Switching Thresholds:</td> <td>ON STATE</td> <td>OFF STATE</td> <td>HYSTERESIS</td> </tr> <tr> <td>TTL Mode:</td> <td>&lt; 0.8 Volts</td> <td>&gt; 2.0 Volts</td> <td>0.9 Volts</td> </tr> <tr> <td>10-50V Sink Mode:</td> <td>&lt; 40% V supplied</td> <td>&gt; 70% V supplied</td> <td>10% V supplied</td> </tr> <tr> <td>10-50V Source Mode:</td> <td>&gt; 70% V supplied</td> <td>&lt; 40% V supplied</td> <td>10% V supplied</td> </tr> </table> <p>Input Impedance: 15,000 ohms</p> <p>Response Time:<br/>50 microseconds (Filter out)<br/>10 milliseconds (Filter in)</p> |                  |                  |                | Switching Thresholds: | ON STATE | OFF STATE | HYSTERESIS | TTL Mode: | < 0.8 Volts | > 2.0 Volts | 0.9 Volts | 10-50V Sink Mode: | < 40% V supplied | > 70% V supplied | 10% V supplied | 10-50V Source Mode: | > 70% V supplied | < 40% V supplied | 10% V supplied |
| Switching Thresholds:   | ON STATE         | OFF STATE        | HYSTERESIS     |                       |          |           |            |           |             |             |           |                   |                  |                  |                |                     |                  |                  |                |
| TTL Mode:   | < 0.8 Volts      | > 2.0 Volts      | 0.9 Volts      |                       |          |           |            |           |             |             |           |                   |                  |                  |                |                     |                  |                  |                |
| 10-50V Sink Mode:   | < 40% V supplied | > 70% V supplied | 10% V supplied |                       |          |           |            |           |             |             |           |                   |                  |                  |                |                     |                  |                  |                |
| 10-50V Source Mode:   | > 70% V supplied | < 40% V supplied | 10% V supplied |                       |          |           |            |           |             |             |           |                   |                  |                  |                |                     |                  |                  |                |

FIGURE 1. SPECIFICATIONS

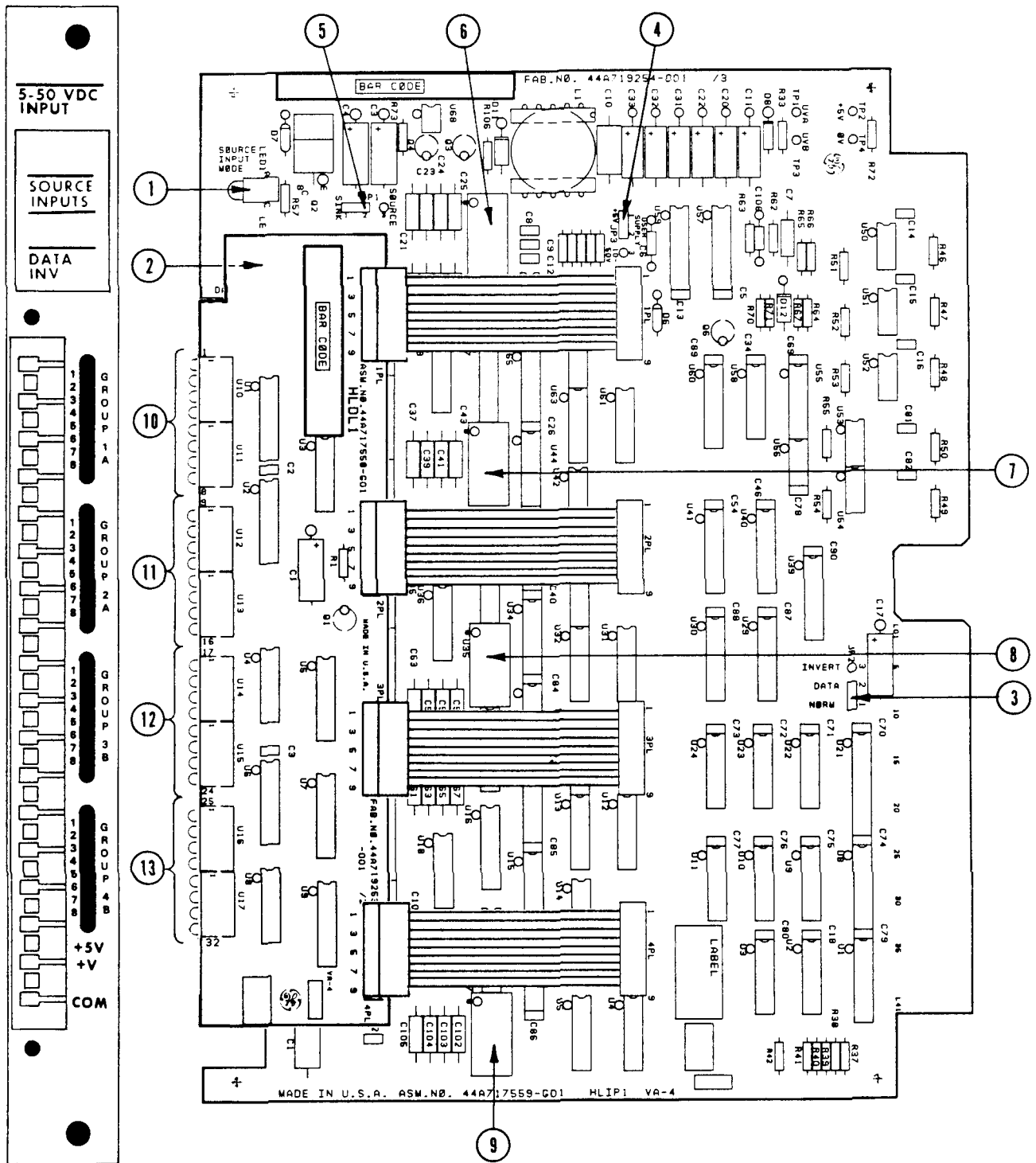

FIGURE 2A. USER ITEMS (Part 1 of 2)  
High Density Input Module With Status Indicator Lights

- ① LED Indicator  
ON: Source Input mode  
OFF: Sink Input mode
  - ② LED Indicator  
ON: Input Data Inverted  
OFF: Input Non-Inverted
  - ③ Jumper JP2: 1-2 Position Data Normal  
2-3 Position Data Invert
  - ④ Jumper JP3: 1-2 Position 5V user supply  
2-3 Position 10-50V user supply
  - ⑤ Jumper JP1: 1-2 Position Sink Mode  
2-3 Position Source Mode
- Selectable Filter-DIP Switches
- Switch OPEN: 50 microseconds delay on Input switch in OPEN position (depressed toward front of module).

Selectable Filter-DIP Switches (continued)

Switch CLOSED: 10 milliseconds delay on input.

| KEY | GROUP | INPUTS      | SWITCHES    |
|-----|-------|-------------|-------------|
| ⑥   | 1     | 1 through 8 | 1 through 8 |
| ⑦   | 2     | 1 through 8 | 1 through 8 |
| ⑧   | 3     | 1 through 8 | 1 through 8 |
| ⑨   | 4     | 1 through 8 | 1 through 8 |

LEDs - Illuminated when current flowing at input terminal.

| KEY | GROUP | INPUTS      | LEDs          |
|-----|-------|-------------|---------------|
| ⑩   | 1     | 1 through 8 | 1 through 8   |
| ⑪   | 2     | 1 through 8 | 9 through 16  |
| ⑫   | 3     | 1 through 8 | 17 through 24 |
| ⑬   | 4     | 1 through 8 | 25 through 32 |

FIGURE 2B. USER ITEMS (Part 2 of 2)

| INPUT NUMBER | DIP SWITCH POSITION |   |   |   |   | INPUT NUMBER | DIP SWITCH POSITION |   |   |   |                                    | INPUT NUMBER | DIP SWITCH POSITION |   |   |   |   |
|--------------|---------------------|---|---|---|---|--------------|---------------------|---|---|---|------------------------------------|--------------|---------------------|---|---|---|---|
|              | 7                   | 6 | 5 | 4 | 3 |              | 7                   | 6 | 5 | 4 | 3                                  |              | 7                   | 6 | 5 | 4 | 3 |
| 1- 32        |                     |   |   |   |   | 353-384      | X                   |   | X | X | 705-736                            | X            |                     | X | X |   |   |
| 33- 64       |                     |   |   | X |   | 385-416      | X                   | X |   |   | 737-768                            | X            |                     | X | X | X |   |
| 65- 96       |                     |   |   | X |   | 417-448      | X                   | X |   | X | 769-800                            | X            | X                   |   |   |   |   |
| 97-128       |                     |   |   | X | X | 449-480      | X                   | X | X |   | 801-832                            | X            | X                   |   |   | X |   |
| 129-160      |                     |   | X |   |   | 481-512      | X                   | X | X | X | 833-864                            | X            | X                   |   | X |   |   |
| 161-192      |                     |   | X | X |   | 513-544      | X                   |   |   |   | 865-896                            | X            | X                   |   | X | X |   |
| 193-224      |                     |   | X | X |   | 545-576      | X                   |   |   | X | 897-928                            | X            | X                   | X |   |   |   |
| 225-256      |                     |   | X | X | X | 577-608      | X                   |   | X |   | 929-960                            | X            | X                   | X |   | X |   |
| 257-288      |                     | X |   |   |   | 609-640      | X                   |   | X | X | 961-992                            | X            | X                   | X | X |   |   |
| 289-320      |                     | X |   | X |   | 641-672      | X                   | X |   |   | 993-1024 } X X X X X<br>(NOT USED) |              |                     |   |   |   |   |
| 321-352      |                     | X | X |   |   | 673-704      | X                   | X | X |   |                                    |              |                     |   |   |   |   |

= Switch in OPEN Position (Depressed to the Left)  
Switches No. 1 and No. 2 should be in CLOSED Position

FIGURE 3. DIP SWITCH SETTINGS

### INSTALLATION

The High-Density Input module can be installed in an I/O Rack in a Model 60 CPU Rack or in a Series Six Plus CPU Rack. Before installing the module, the Dual-In-Line Package (DIP) switches immediately behind the card slot on the rack backplane should be set to reserve 32 consecutive input points in the Input Status Table of the CPU. For specific DIP switch settings, refer to figure 3.

The circuit-board jumpers must also be set to configure the module to operate in the desired system configuration. For example: sink or source, invert or non-invert, TTL or 10-50 volt inputs. Refer to figure 2, User Items and appropriate figure 5, 6 or 7.

#### NOTE

**Jumper JP3 must be set correctly for the voltage in use. See figures 5, 6, and 7. Failure to set JP3 to the correct position may prevent module from operating.**

The ON state of an input *point*, as defined in figure 1, results in a "1" being loaded into the Input Status Table with the module in the non-inverting mode; an input in the OFF state results in a "0" being loaded into the Input Status Table.

If input connections for 10 to 50V modes shown in figures 6 and 7 are used, a closed switch turns the input ON; an open switch turns the input OFF. In the absence of user power, all inputs will appear to be in the OFF state.

It is recommended that the extraction/insertion tool furnished with the CPU be used to remove or install the circuit boards. With the board in place in the rack, the edge connector on the faceplate should be slipped over the circuit board so that proper contact is made. The faceplate can then be secured to the rack using the thumbscrews at the top and bottom.

Refer to figures 4 for a typical symbolic input circuit.

Refer to figures 5, 6 and 7 for Typical User Input connections to this module. In the TTL mode of operation, the low (negative) side of each of the TTL inputs must be returned to the Module Common (COM) terminal Pin 34.

#### NOTE

Set Jumper JP3 correctly as follows:

| VOLTAGE | TO PIN  | SET JP3 |
|---------|---------|---------|
| 5V      | 33 & 34 | 1-2     |
| 10-50v  | 34 ONLY | 2-3     |

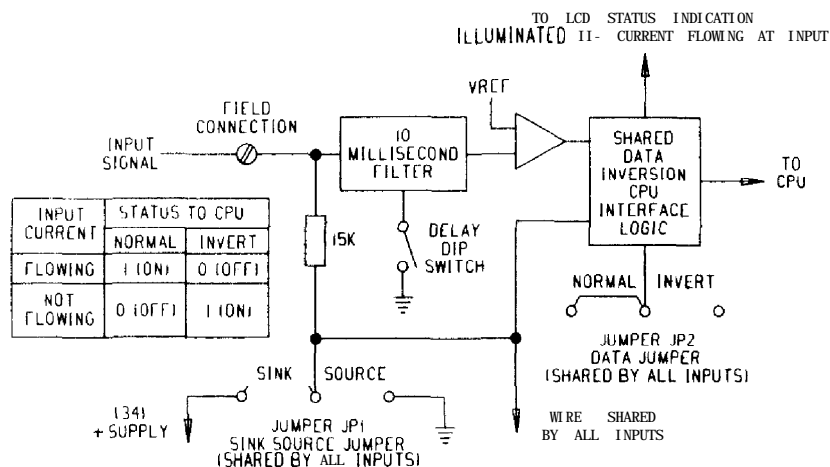

FIGURE 4. TYPICAL SYMBOLIC INPUT CIRCUIT; 1 OF 32

**CAUTION**

Do not apply more than +5 volts to the 5 volt terminal nor jumper the 5 volt (Pin 33) terminal to the 50 volt terminal (Pin 34) when using this module in the 10-50V mode. Failure to observe this caution will damage the module due to excessive voltage on the logic circuitry.

NOTE

1. PS1 is a 5 volt power supply supplied by user and wired as shown.
2. Jumper JP3 must be in the 1-2 position when using this type power.
3. Jumper JP1 must be set to the 1-2 (SINK) position for TTL current loads.
4. Module can be wired and setup for only 1 mode of operation at a time.
5. The low (negative) of each of the users TTL input circuits must be returned to the module common (COM) terminal, Pin 36.
6. See figures 2 and 3 for other switch and jumper settings.
7. Jumper Pins 33 and 34 together on user connector.

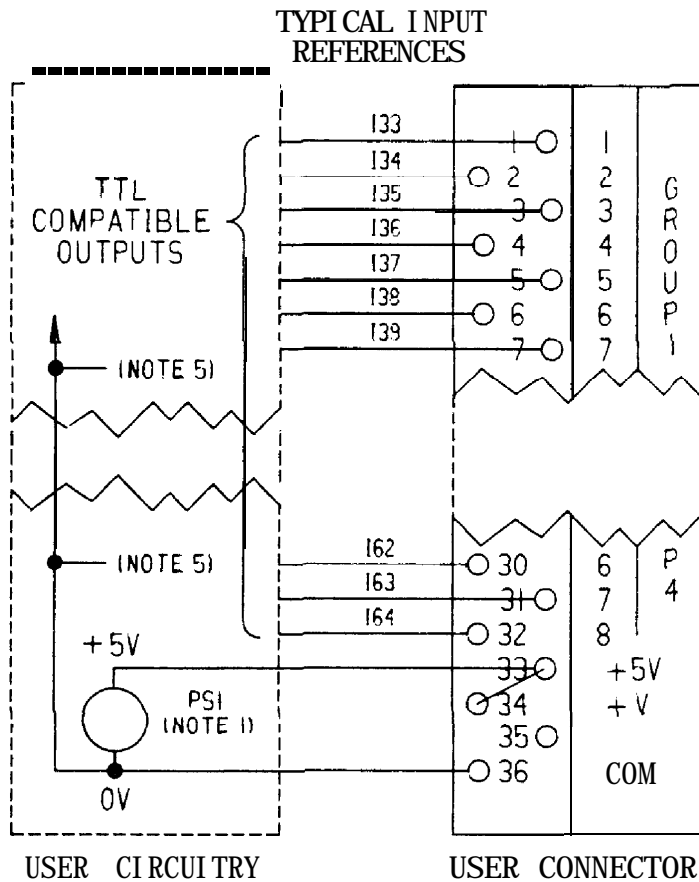

FIGURE 5. RECOMMENDED USER INPUT CONNECTIONS FOR TTL MODE OPERATION

**CAUTION**

Do not apply more than +5 volts to the 5 volt terminal nor jumper the 5 volt (Pin 33) terminal to the 50 volt terminal (Pin 34) when using this module in the 10-50V mode. Failure to observe this caution will damage the module due to excessive voltage on the logic circuitry.

NOTE

1. PSI is a 10-50 volt power supply supplied by user and wired as shown.
2. Jumper JP3 must be in the 2-3 position when using this type power.
3. Jumper JPI must be set to the 1-2 (SINK) position.
4. Module can be wired and setup for only 1 mode of operation at a time.
5. See figures 2 and 3 for other switch and jumper settings.
6. Do not jumper Pin 33 to 34 on user connector.

**TYPICAL INPUT REFERENCES**

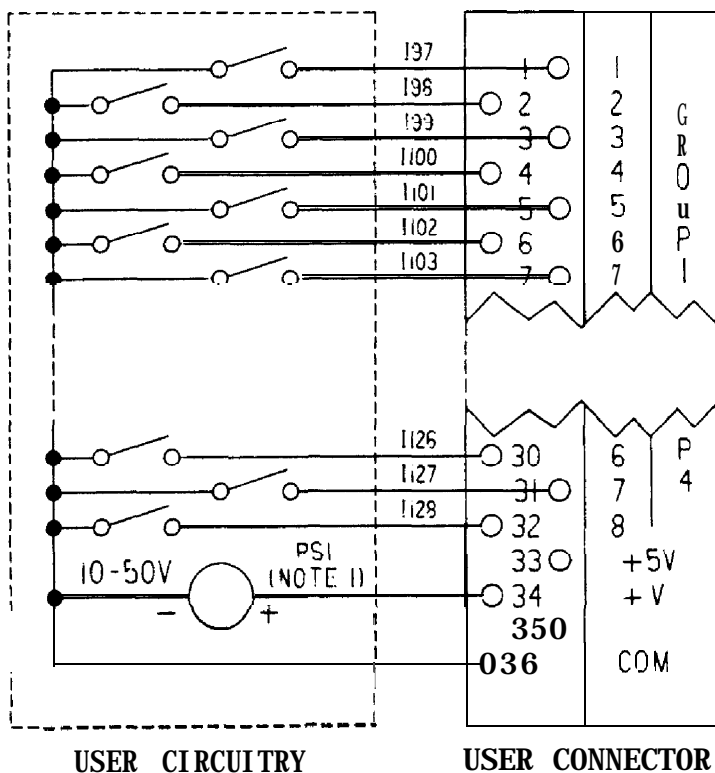

FIGURE 6. RECOMMENDED USER INPUT CONNECTIONS FOR 10-50 VOLT SINK MODE OPERATION

**CAUTION**

Do not apply more than +5 volts to the 5 volt terminal nor jumper the 5 volt (Pin 33) terminal to the 50 volt terminal (Pin 34) when using this module in the 10-50V mode. Failure to observe this caution will damage the module due to excessive voltage on the logic circuitry.

**NOTE**

1. PS1 is a 10-50 volt power supply supplied by user and wired as shown.
2. Jumper JP3 must be in the 2-3 position when using this type power.
3. Jumper JP1 must be set to the 2-3 (SOURCE) position.
4. Module can be wired for only 1 mode of operation at a time.
5. See figures 2 and 3 for other switch and jumper settings.
6. Do not jumper Pin 33 to 34 on user connector.

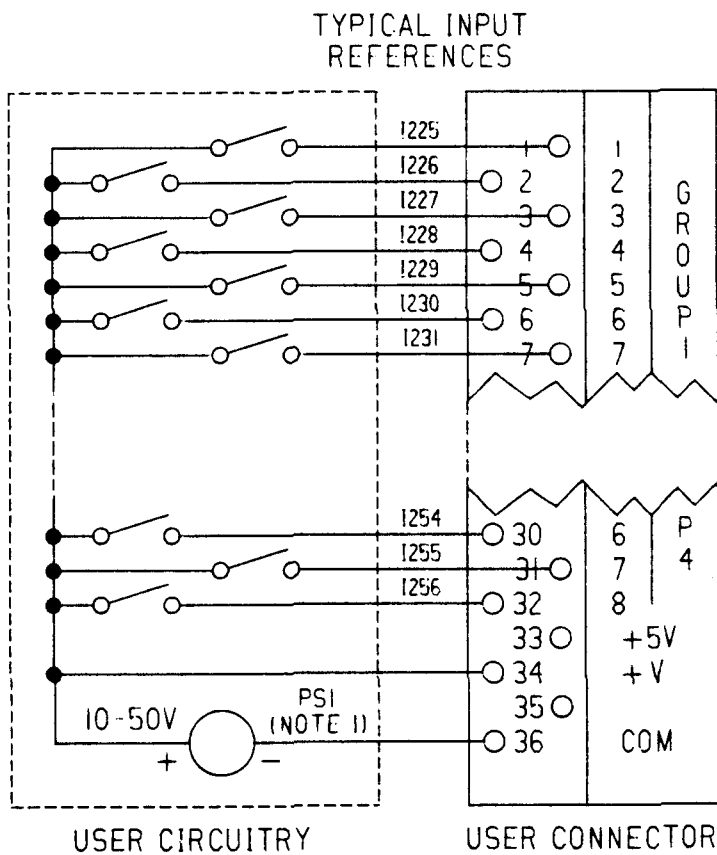

FIGURE 7. RECOMMENDED USER INPUT CONNECTIONS FOR 10-50 VOLT SOURCE MODE OPERATION

**ORDERING INFORMATION**

| <u>Module</u>                         | <u>Circuit Board and Faceplate</u> | <u>Circuit Board Only</u> | <u>Faceplate Only</u> |
|---------------------------------------|------------------------------------|---------------------------|-----------------------|
| 5 to 50 V dc Input<br>With Indicators | IC600BF83 1                        | IC600YB831                | IC600FP831            |



This symbol on the nameplate means the product is listed by Underwriters Laboratories Inc. (UL Standard No. 508, Industrial Control Equipment, subsection Electronic Power Conversion Equipment.)

For further information, contact your local GE Fanuc sales office

GE FANUC AUTOMATION NORTH AMERICA, INC., CHARLOTTESVILLE, VIRGINIA

JULY, 1986