

GEK-90842

## Analog Output IC610MDL166

### Introduction

The Analog Output module provides two independent output channels, each capable of converting 8 bits of binary data to an analog output. This module can be used with any of the Series One family of programmable controllers. The Series One Plus, in addition to the basic functions, provides data operations (including math functions), which allows other types of operations to be performed when using the analog output module. Each Analog Output module requires 16 I/O references for addressing.

Although this module can be used with the Series One and Series One Junior, in addition to the Series One Plus, certain programming techniques will make better use of the capabilities of the Analog Output module with these PCs. An APPLICATION NOTE will be issued explaining those techniques in detail.

### Hardware Features

Each channel can provide either a voltage output (0 to +10 V dc) or current output (4 to 20 mA source). Voltage or current selection for each channel is user selected by how the field wiring is connected on the screw terminals on the faceplate. Resolution is 8 bits, which allows a maximum digital value of 255 to be converted. Eight LEDs for each channel on the faceplate provide an 8-bit binary display of the data output for each channel.

User field wiring is made to a removable terminal board on the module's faceplate. A hinged plastic terminal cover on the terminal board protects the terminals. The terminal cover has a removable label that can be used to record circuit information.

The maximum conversion time is 10 microseconds and does not add to the scan time of the CPU. Both channels are converted with each scan.

### Power Requirements

This module requires an external 24 V dc power supply. The 24 V dc supply in Series One racks can be used, however the current provided by the rack is 100 mA, which is sufficient current for one Analog Output channel, since the module requires up to 85 mA for operation. The maximum load for both channels is 170 mA.

### General and Electrical Specifications

Specifications for this module are provided in the following table.

Table 6-16. Analog Output Module Specifications

Number of Channels	2 (Independent)
Analog Output Ranges	0 to +10 V dc or 4 to 20 mA (selectable for each channel on faceplate terminals)
Resolution	8-bit binary (1 in 256)
Digital Input Data	8 bits, binary from the CPU
I/O Points Required	16 consecutive (per slot assignments for 16 points, 0 to 7 and 100 to 117, etc.)
LED Display (16 LEDs) 8 LEDs for each channel	8-bit binary data display of output data for each channel
Operating Temperature	0 to 60° C (32 to 140° F)
Relative Humidity	5% to 95% (non-condensing)
Output Impedance	< 0.5L (Voltage Output)
Output Current	10 mA, maximum (Voltage Output)
External Resistor	550L, maximum (Current Output)
Conversion Start	At start of CPU's scan
Conversion Time	10 msec, maximum
Accuracy	0.2% at 25°C
Accuracy vs. Temperature	30 ppm (parts per million) per 1°C
External Power Source	+24 V dc, 85 mA (maximum)
9 V dc Power Consumption	55 mA (Supplied by rack power supply)

### I/O Reference Definitions

The Analog Output module uses 16 consecutive I/O points, beginning with the first I/O reference assigned to the I/O slot selected for the module. In the table, it is assumed that the Analog Output module is placed in slot 2 of a properly configured 5 or 10-slot CPU rack (references 0 to 10 and 100 to 110). *These references are used for the example only, other valid references for I/O slots that allow 16 references can be used.* The following table defines the use of each of the I/O points.

Table 6-17. I/O Point Definition

I/O POINT	DEFINITION	WEIGHT	I/O TYPE
CHANNEL	DATA	WEIGHT	
0	Channel 1 - Data Bit 1	1	Output
1	Channel 1 - Data Bit 2	2	Output
2	Channel 1 - Data Bit 3	4	Output
3	Channel 1 - Data Bit 4	8	Output
4	Channel 1 - Data Bit 5	16	Output
5	Channel 1 - Data Bit 6	32	Output
6	Channel 1 - Data Bit 7	64	Output
7	Channel 1 - Data Bit 8	128	Output
100	Channel 2 - Data Bit 1	1	Output
101	Channel 2 - Data Bit 2	2	Output
102	Channel 2 - Data Bit 3	4	Output
103	Channel 2 - Data Bit 4	8	Output
104	Channel 2 - Data Bit 5	16	Output
105	Channel 2 - Data Bit 6	32	Output
106	Channel 2 - Data Bit 7	64	Output
107	Channel 2 - Data Bit 8	128	Output



### Analog Output Module Features

Figure 6.59 is an illustration of the faceplate for the Analog Output module, showing its features and user wiring connections.

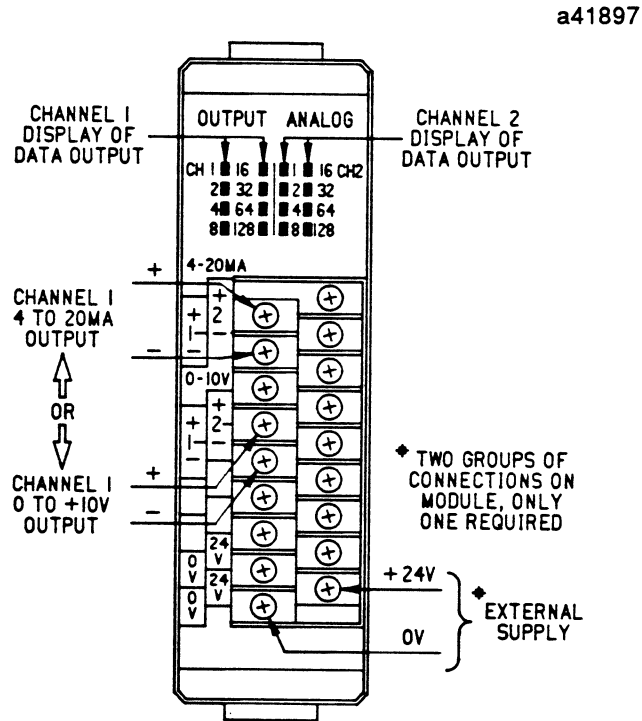

Figure 6-59. Analog Output Module Faceplate