

Current-source 4 Input/2 Output Analog Blocks

June 2002

GFK-0422D

Description

Current Source Analog I/O blocks are used to interface a controller to devices that provide or accept 4mA to 20mA analog signals. Two block versions are available:

- **115 VAC Current-source Analog I/O Block (IC66*BBA104)**
- **24/48 VDC Current-source Analog I/O Block (IC66*BBA024)**

These blocks are identical except for the power supply.

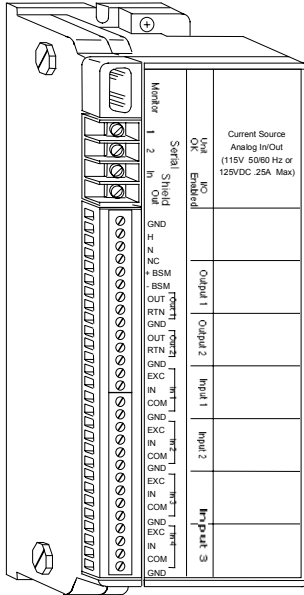

Features

Block features include:

- Six 4-to-20 mA analog circuits: 4 inputs and 2 outputs
- Isolated channels
- No user calibration required for operation
- Software configurable
- Advanced diagnostics
- Dedicated Bus Switching Module control

A Current Source Analog I/O block has four 4 to 20mA current inputs. Each input provides a 24 volt current loop power supply and is isolated from all other circuits within the block. The two output channels provide power and control of two 4-to-20mA current loops. The output channels and BSM circuitry are electrically common, but isolated from the inputs.

All circuits on the block support independent selection of linear scaling values. These values can be used to convert the internal values into engineering units suitable for the application.

Block diagnostics include:

- input low and high alarm detection
- overrange and underrange detection for inputs and outputs
- input open wire detection
- output feedback error detection
- internal fault reporting

A dedicated digital output is provided to drive a Bus Switching Module (version IC66*BSM021 only).

Specifications

Catalog Numbers

115 VAC/125 VDC Current Source Analog I/O Block	IC66*BBA104
Terminal Assembly	IC66*TBA104
Electronics Assembly	IC66*EBA104
24/48 VDC Current Source Analog I/O Block	IC66*BBA024
Terminal Assembly	IC66*TBA024
Electronics Assembly	IC66*EBA024

Block Specifications

Size (height x width x depth)	8.83" (22.44cm) x 3.34" (8.48cm) x 3.91" (9.93cm)		
Weight	4 lbs. (1.8 kg)		
LEDs (I/O Block)	Unit OK, I/O Enabled		
Block to Block Isolation	1500V for one minute		
Group to Group Isolation	1500V RMS		
Heat Dissipation	12 Watts maximum		
BSM Control	Switches one 24/48 VDC BSM (IC66*BSM021)		
Block Power (nominal);	115VAC	125VDC	24/48VDC
Power supply voltage	98-132 VAC	105-145 VDC	18-56
Maximum current	250mA	140mA	600mA
Frequency/ripple	47-63 Hz	10% max. ripple	10% max. ripple
PS dropout time	1 cycle	10 ms min.	10ms min.

Input Specifications

Input accuracy (at 25° C)	0.1% of full scale reading *		
Input resolution	1µA		
Input conversion time	16.6ms to 400ms (user selectable)		
Range	4mA to 20mA		
Overrange capacity	0mA to 25mA		
Input diagnostics	Under / Overrange, High /Low Alarm, Open Wire		
Channel to channel isolation	1500V rms		
Thermal drift (from 25° C)	70 PPM per degree C typical		
Input Impedance	100 Ohms +/-5%		
Normal Mode Rejection	-45 dB at 50, 60 Hz		
Input Excitation:			
Open circuit voltage	24VDC		
Short circuit current	< 75mA		
Loop impedance	1000 Ohms maximum (0mA to 20mA) 800 Ohms maximum (20mA to 25mA)		

Output Specifications

Output accuracy at 25° C	0.15% of full scale reading		
Output resolution	6µA		
Output update frequency	6ms to 8ms typical		
Range	4mA to 20mA		
Overrange capacity	0mA to 24mA		
Output diagnostics	Underrange, Overrange, Feedback error		
Output load	0 Ohms to 850 Ohms		
Thermal drift (from 25°C)	35 PPM per degree C typical		

Environmental Specifications

Operating temperature	0° C to +60° C (+32° to +140° F)		
Storage temperature	-40° to +100° C (-40° to +212° F)		
Humidity	5% to 95% (non-condensing)		
Vibration	5-10 Hz 0.2" (5.08mm) displacement, 10-200 Hz at 1G		

Refer to GFK-0867B for product standards and general specifications.

* In the presence of severe RF interference (IEC 801-3, 10 V/m), accuracy may be degraded to +/-0.25% of full scale reading.

Current-source 4 Input/2 Output Analog Blocks

June 2002

GFK-0422D

Using this Datasheet

This datasheet summarizes information about block installation, configuration, and diagnostics.

Your primary reference should be the Discrete and Analog Blocks User's Manual. It includes detailed instructions for block installation and configuration.

For additional information about systems and communications, including bus specifications, refer to the *I/O System and Communications Manual*.

Compatibility

Hand-held Monitor model IC66*HHM501E (version 3.7) or later is required for configuration.

For an IC697 series PLC, if the CPU is model IC697CPU731, it must be version G or later. If it is model IC697CPU771, it must be version E or later. The programming software must be version 2.02 or later. Bus Controller IC697BEM731C or later is required.

For an IC600 series PLC, the CPU must be rev. 105 or later. For an IC600 series "Plus" PLC, rev. 110 or later is required. The programming software must be rel. 4.02 or later.

For an IC550 series PLC, the CPU must be rev. 3.0 or later. The programming software must be rel. 2.01 or later.

If a Bus Switching Module will be connected directly to the block, it must be the 24/48 VDC version (IC66*BSM021).

Installation Instructions

Carefully inspect all shipping containers for damage. If any equipment is damaged, notify the delivery service immediately. Save the damaged shipping container for inspection by the delivery service. After unpacking the equipment, record all serial numbers. Save the shipping containers and packing material in case it is necessary to transport or ship any part of the system.

Block Mounting

Genius I/O blocks are considered "open equipment" and therefore must be installed within a protective enclosure. They should be located in an area that is clean and free of airborne contaminants. There should be adequate cooling airflow.

The block can be mounted right side up, or upside down. Leave at least 2 inches of space between blocks. Mount the block by drilling two screw or bolt holes for 8-32 hardware. Position the block so that the notches in the upper and lower flanges line up with the mounting holes. Mount the block using 8-32 screws. Use star washers to provide ground integrity.

Grounding

The block's mounting screws must not be used as the only means of grounding the block. Connect the green ground screw on the block to a reliable ground system using a short wire lead, minimum size AWG #12 (avg 3.3mm² in cross-section).

Warning

If mounting screws do not make good ground connection and the ground screw is not connected to a reliable ground, the block is not grounded. Electrical shock hazard exists. Death or personal injury may result.

Block Wiring

Do not overtorque the terminal screws. Recommended torque for all terminals is 6 in/lb (.678 N/M).

Serial Bus Wiring

Terminals 1 to 4 are for the serial bus. These terminals accept one AWG #12 wire (avg 3.3mm² cross-section) or two AWG #14 wires (each avg 2.1mm² in cross-section). The minimum recommended wire size is AWG #22 (avg .36mm² in cross-section).

Terminals 1 - 4 can also accommodate spade or ring terminals up to 0.27 inch (6.85mm) wide with a minimum opening for a #6 screw, and up to 0.20 inch (5.1mm) depth from the screw center to the back barrier. Be sure unshielded wire ends are not longer than 2 inches (5 cm).

Using one of the cable types recommended in the *System and Communications User's Manual*, connect the serial bus to terminals 1- 4. (If the block will control a Bus Switching Module, see below instead.)

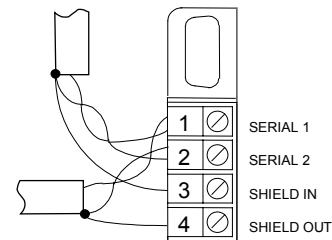

If the block is at either end of the bus, connect a terminating resistor of the appropriate type (see the System and Communications User's Manual for details) across its Serial 1 and Serial 2 terminals.

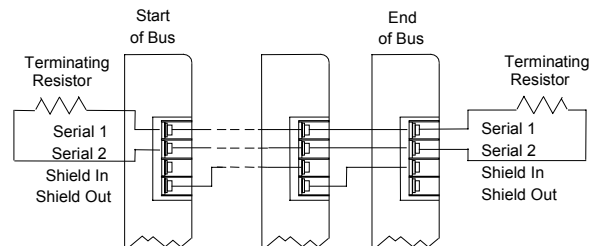

Connecting a Bus Switching Module

If a Bus Switching Module will be connected *directly* to the block, attach it to the serial bus terminals as shown on the next page. Connect the serial bus cables to the BSM as instructed in the *Bus Switching Module datasheet*. Wire either of the BSM pigtail wires to terminal 9 and the other to terminal 10.

Current-source 4 Input/2 Output Analog Blocks

June 2002

GFK-0422D

Field Wiring

Terminals 5 to 32 are for field devices. They take a single wire up to AWG #14 (avg 2.1mm² in cross-section). Minimum recommended size is AWG #20 (avg .54mm² in cross-section).

The ground (GND) terminal (5) is for block safety. It is connected to the block chassis, and to terminals 13, 16, 20, 24, 28, and 32 which are marked GND. Each channel has one ground terminal for shield termination, if desired.

Wiring for Block Power

For block power, connect an appropriate power source to terminals 6 and 7. For AC block power, connect the source to the H terminal and neutral to the N terminal. For DC block power, connect the source to the DC+ terminal and the return to the DC- terminal.

Self-powered or externally-powered transmitters are wired differently from those powered by the block.

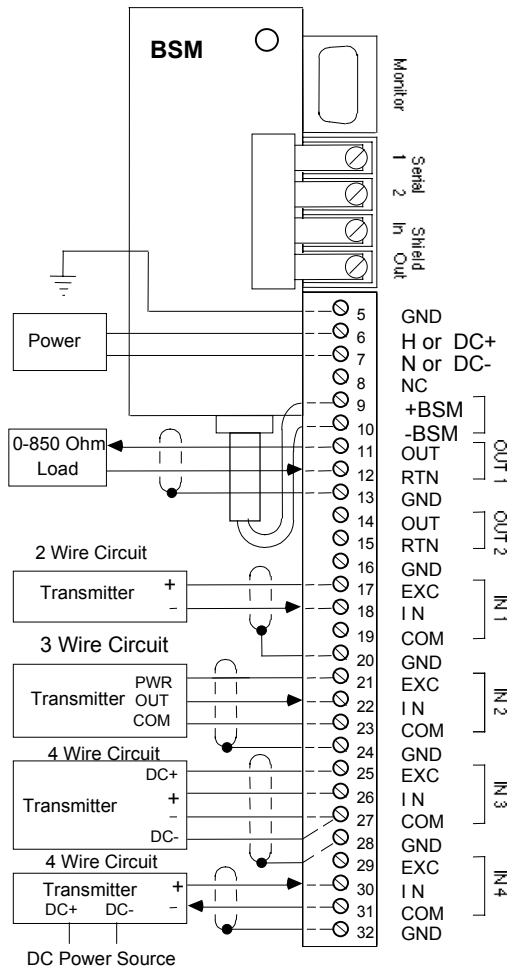

External Resistors for Grounded Output Loads

If both of the block's output loads are grounded, and the loads are widely separated by distance, an external resistor should be installed in each load's return line to the block. This will prevent possible damage to the block caused by the significant voltage differences that may occur between the two ground points. 10 Ohm resistors are suggested.

Removing an Electronics Assembly

The block's Electronics Assembly can be replaced with a compatible model without removing field wiring or reconfiguring the block.

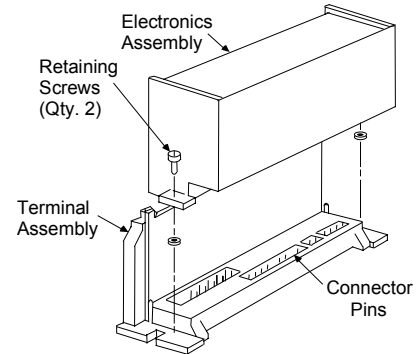

1. Unscrew the retaining screws at the top and bottom of the block.
2. Using a Block Puller (IC660BLM507), engage the tabs in the first vent slots. Move the tool to the center of the block and squeeze the handle.
3. Pull the Electronics Assembly upward.

Warning

If power is applied to the field terminals, power is also exposed on the connector pins at the base of the Terminal Assembly, and electrical shock hazard exists. Do not touch the connector pins! Death or injury may result.

Inserting an Electronics Assembly

1. Align the Electronics Assembly in the guides and push down firmly.

Caution

Do not exert excessive force; it may damage the block.

2. If unusual resistance is met, remove the Electronics Assembly. If power is applied to the block, DO NOT TOUCH THE CONNECTOR PINS! Inspect the Terminal Assembly, connector receptacle, and connector edge board (on the Electronics Assembly). Be sure the keying matches. Remove any obstacles and reinsert the Electronics Assembly. Pay close attention to the alignment of the guide pins.
3. Secure the Electronics Assembly with the screws on the top and bottom of the Terminal Assembly.

LEDs

The block's Unit OK and I/O Enabled LEDs show its operating status.

Unit OK	I/O Enabled	Meaning
ON	ON	Block functioning, CPU communicating
ON	OFF	Block functioning No CPU communications for 3 bus scans
ON	Blinking	Block functioning, Circuit forced
Blinking	ON	Circuit fault, CPU communicating
Blinking	OFF	Circuit fault No CPU communications for 3 bus scans
Alternate Blinking		Circuit fault, Circuit forced
Synchronous Blinking		No CPU communications - block number conflict
OFF	Blinking	Electronics/Terminal Assembly mismatch
OFF	OFF	No block power, or block faulty

Current-source 4 Input/2 Output Analog Blocks

June 2002

GFK-0422D

Block Operation

These blocks have four independent inputs and two independent outputs.

Inputs

Input channels use voltage to frequency converters and counters to translate analog currents to digital values. The block converts digital values to engineering units values, which it supplies to the CPU.

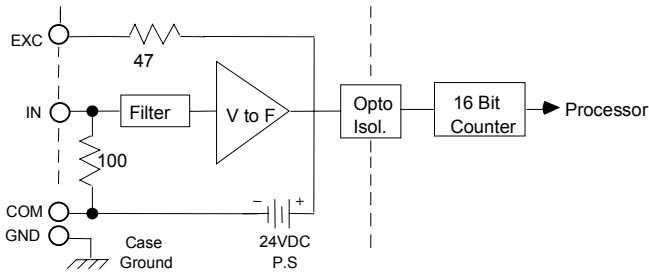

Each input has a 24 volt current loop power supply, capable of providing 25mA of current. Each input is isolated from all other circuits on the block. Input accuracy is 0.1%. Input conversion time can be selected from 16 to 400ms. Resolution increases as conversion time lengthens. Input resolution is 1mA for 200ms conversion time.

Outputs

The two independent output circuits are electrically common to each other and the BSM outputs, but isolated from all other circuits on the block. Power for the outputs' current loops is provided by the block.

Output channels use a dual 12-bit digital to analog converter, and can independently control currents from 0mA to 24mA. Output resolution is 6mA.

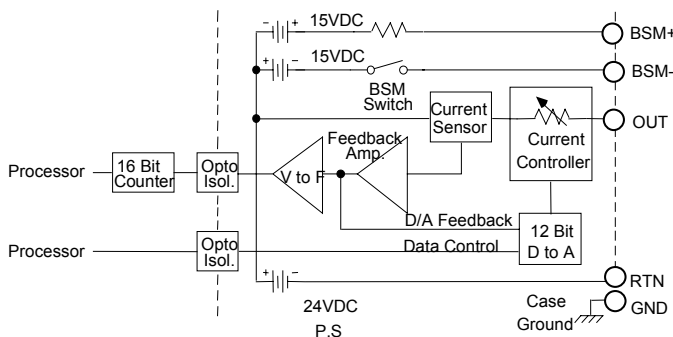

Two additional A to D channels are used to check the two output channels after a programmable settling time. The block indicates a fault if the feedback from these channels does not match the commanded value to within 250mA.

Diagnostics

The block's advanced diagnostics provide the messages listed below. Fault messages can be cleared from the Hand-held Monitor or the CPU.

High Alarm: Input over its high alarm limit

Low Alarm: Input under its low alarm limit

Open Wire: Input current is below 2mA

Input Overrange: Signal exceeds 25mA

Input Underrange: Current is negative, or 0 mA.

Output Overrange: Commanded output exceeds 24mA

Output Underrange: Commanded output is less than 0 mA.

Output Feedback Error: Wiring error or hardware fault.

Note: Nuisance diagnostics may be reported if the Output Feedback Time selected for the circuit is too brief. If this happens, increase the feedback time or disable output feedback testing.

Note: If the block is used outside the 4-20mA range, false Output Feedback diagnostics may be reported if a commanded output value is very low. Feedback data checking can be disabled when an output is commanded to less than 1mA, and re-enabled when the output is commanded to a value above 1mA.

Configuration

First, the block must be configured with a Hand-held Monitor to:

- Enter its Device Number (serial bus address).
- Enter its Reference Number (required only for IC600 and IC550 series PLCs only).

Note: If a block is configured offline, it must be properly grounded and have a 75 Ohm resistor installed across its Serial 1 and Serial 2 terminals. See the *Discrete and Analog I/O Blocks User's Manual* for instructions. The rest of the features can be configured either using a Hand-held Monitor, or by sending a Write Configuration datagram to the block from the host.

Feature	Circuit /Block	Factory Setting	Selections
Device Number	Block	null	0 to 31 (must be selected)
Reference Address	Block	none	Depends on host CPU type
Baud Rate, Kbd	Block	153.6 std	153.6 std, 153.6 ext, 76.8, 38.4
Report Faults	Circuit	yes	yes/no
Channel active	Circuit	active	active/inactive
Input Scaling	Circuit	1µA per eu	+/-32767 eng units 0 to +25000µA
Output Scaling	Circuit	1µA per eu	+/-32767 eng units 0 to +24000µA
Input conversion time	Block	400ms	16 to 400ms
Low Alarm	Circuit	0	+/-32767 eng. units
High Alarm	Circuit	+25000	+/-32767 eng. units
Output Feedback Enabled	Circuit	yes	yes/no
Output Feedback Time	Circuit	0ms	0 to 255ms
Hold Last State	Circuit	no	yes/no
Output Default	Circuit	4000	+/-32767 eng. units
BSM Present	Block	no	yes/no
BSM Controller	Block	no	yes/no
Outputs Default Time	Block	2.5 sec	2.5/10 seconds
CPU Redundancy	Block	none	none/standby
Configuration Protection	Block	disabled	enabled, disabled