



This Datasheet for the

[IC670ALG330](#)

Analog Output Current 8 Channel

<http://www.qualitrol.com/shop/p-14495-ic670alg330.aspx>

Provides the wiring diagrams and installation guidelines for this GE Field Control module.

For further information, please contact Qualitrol Technical Support at

1-800-784-9385

support@qualitrol.com

Analog Output Module

IC670ALG330

GFK-1376B
June 1997

8 Point Analog Current-Source Output Module

The 8 Point Analog Current-source Output Module (IC670ALG330) accommodates 8 current-loop outputs on a common power supply. It provides eight channels of analog current outputs with user-configurable scaling for each channel.

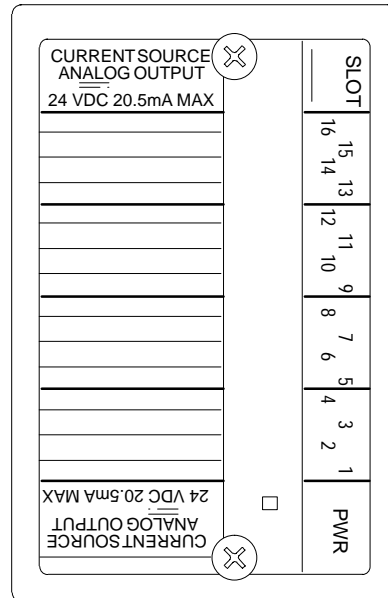

46770

- Supports 8 channels of output currents ranging from 0 to 20 mA with 16-bit resolution.
- Output overrange provided for up to approximately 20.48mA.
- Uses both word and bit data types.
- Can be field-recalibrated or reset to factory calibration. All calibration data is stored in FLASH memory.
- Individual channel configuration including default output level and scaling parameters.
- Reports Under/Overage, and Open Wire alarms.

Power Sources

The 8 Point Analog Current-source Output Module requires a separate source of power for the outputs.

LEDs

A single indicator shows module status:

- ON: normal operation
- Intermittent flashing: module fault
- OFF: No backplane power, no user power, or fatal fault.

GFK-1376B
June 1997

8 Point Analog Current-Source Output Module

Module Operation

During operation, the module receives engineering units output data from the Bus Interface Unit (BIU). It scales this data according to its calibration and configured scaling parameters, then converts the data to output current in the range of 0 mA to approximately 20.48 mA.

If the scaled data is below the minimum limit of the digital to analog converter, the module sets the output current to 0 mA. If the scaled data is above the maximum limit of the digital to analog converter, the module sets the output current to approximately 20.48 mA.

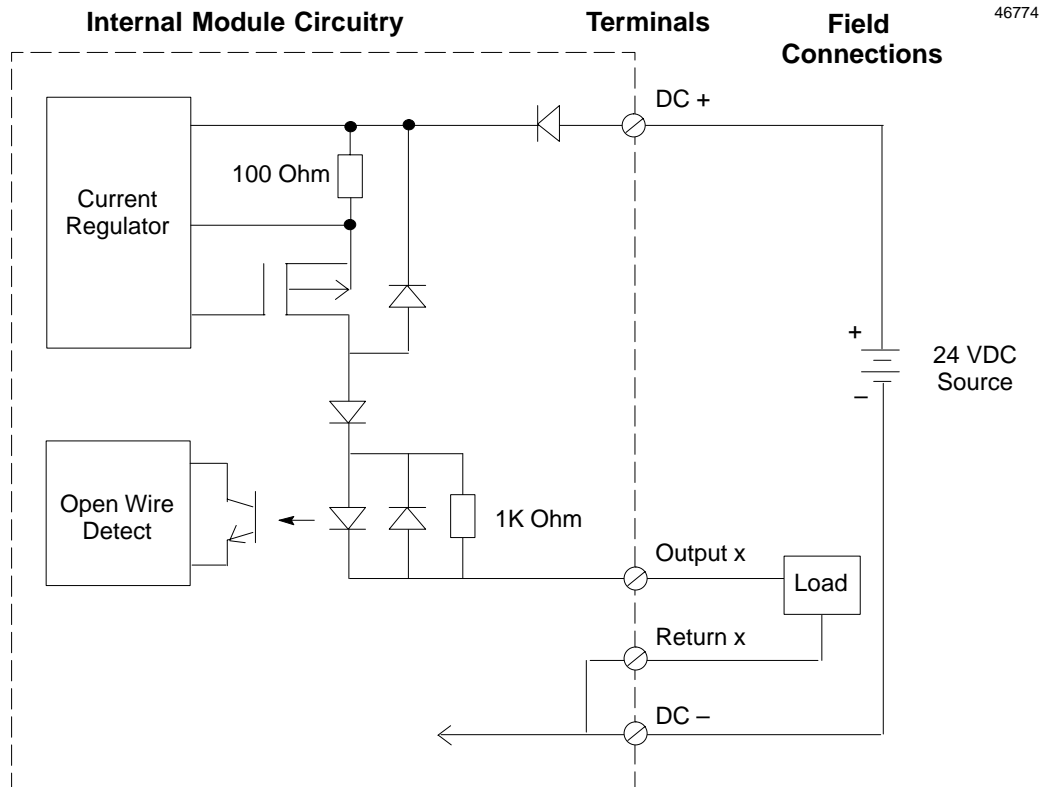

The 8 Point Analog Current-source Output Module provides the following alarms:

- **Over/Underrange:** indicates that an engineering units value sent by the host has resulted in an output value that is within approximately 30 microAmps of the module's maximum or minimum.
- **Open Wire:** The actual output value is below approximately 2mA. The Open Wire alarm is automatically enabled whenever the low span (output current) value is configured equal to or above 3.5mA.

If an alarm occurs, the module sets a bit in its optional discrete input data. These alarm bits can be monitored by the application logic. They can be reset by sending appropriate alarm-clearing discrete output data to the module.

8 Point Analog Current-Source Output Module

GFK-1376B
June 1997

Host Interface

The 8 Point Analog Current-source Output Module uses the following types of data:

- 0–8 words of analog output data
- 0–4 bytes of discrete input data for module and channel status.
- 0–2 bytes of discrete output data for clearing alarms.

The module exchanges data with a Bus Interface Unit in the same manner as other types of I/O modules—it provides all its input data and status bits when requested by the BIU, and receives fault-clearing commands and analog output data from the BIU.

The module can also be configured for “Group” data transfer with the BIU or with other intelligent devices in the same Field Control station. Group data transfer, and the steps for configuring it, are described in the *Bus Interface Unit User’s Manual*.

Compatibility

This module must be used with a Bus Interface Unit revision 2.0 or later.
Group data transfer is only available with revision 1.1 or later.

Keying Locations

Optional keying locations for the 8 Point Analog Current-source Output Module are:

KeyingLocations									
A	B	C	D	E	F	G	H	J	K
✓		✓						✓	✓

8 Point Analog Current-Source Output Module**Module Configuration Overview**

The 8 Point Analog Current-source Output Module is usually configured using a compatible hand-held programmer. The configuration can also be read or written from the bus in a system that supports such configuration. The table below summarizes configuration choices and defaults. The module will power up with the default configuration settings. For configuration instructions, refer to the *Bus Interface Unit User's Manual*.

Module Parameter	Description	Default	Choices
AnalogOutput Data Length	Length in words for the module's analog output data in the BIU's analog output (AQ) table.	8 words	0-8
AnalogOutput Reference	Starting offset for the module's analog output data in the BIU's analog output (AQ) table.		Userselected
Discrete Input Data Length	Length in bits for the module's optional discrete input diagnostic data in the BIU's discrete input (I) table.	32 bits	0, 8, 16, 24, 32
Discrete Input Reference	Starting offset for the module's diagnostic data in the BIU's discrete input (I) table.		Userselected
Discrete Output Data Length	Length in bits of the module's optional discrete output fault clearing data in the BIU's discrete output (Q) table.	16 bits	0, 8, 16
Discrete Output Reference	Starting offset for the module's fault clearing data in the BIU's discrete output (Q) table.		Userselected
(BIU) Defaults: Input data	If the BIU loses communications with the module, the module's discrete input (diagnostic) data can be set to zero or hold its last state.	Zero	Zero, Hold Last State
(BIU) Defaults: Output data	If the BIU loses communications with the network, the module's discrete and analog output data can be set to zero or hold its last state.	Zero	Zero, Hold Last State
LocalDefaults: Outputs	If a reset or local failure occurs, the module can set the actual outputs to zero or hold their last values (this requires local power).	Zero	Zero, Hold Last State
BIU Timeout	If the I/O scan is enabled and the module does not receive output data for this duration, the module defaults its outputs. Outputs remain defaulted until the module receives output data or power is cycled. The default output value is the Local Defaults setting. This parameter can only be changed by sending the module a configuration over the bus.	500mS	0 to 65535 mS
Channel Active	Determines whether a channel will respond to commanded analog output data and return alarms. If a channel is inactive its output is zero. If a previously-active channel is reconfigured as inactive, any pre-existingalarms can still be cleared using Q data.	Active	Inactive, Active
Range	There are three sets of default scaling parameters. (1) 4mA = 4000 (AQ), 20mA = 20000 (AQ) (2) 4mA = 0 (AQ), 20mA = 32000 (AQ) (3) 0mA = 0 (AQ) 20mA = 32000 (AQ) Any of these ranges can be edited by changing the parameters listed below. Custom scaling will result in a default range value of 0 (none).	1	1, 2, 3
Span Low	Actual current in microAmps to be scaled from low engineering units.	4000	0 to 20000
Span High	Actual current in microAmps to be scaled from high engineering units.	20000	0 to 20000
Engineering Low	Engineering units equivalent of the low span value.	4000	-32,768 to +32,767
Engineering High	Engineering units equivalent of the high span value.	20000	-32,768 to +32,767

8 Point Analog Current-Source Output ModuleGFK-1376B
June 1997

Module Features

Channel Active

Each channel can be configured as either active or inactive.

If a channel is Inactive, its output is 0mA and the analog output data for the channel is not used. Alarm (optional discrete input) data for the channel is not updated for a channel that has been configured as Inactive.

If the configuration of a channel is changed from Active to Inactive, the module stops updating its alarm data. Pre-existing alarms can still be cleared using the module's configured discrete output bits.

Local Output Defaults

In addition to being able to configure data defaults of zero or hold last state for the module's data in the BIU, local output defaults for the module are also configurable. These module local defaults determine whether the module will set the actual output currents to zero milliAmps or hold their last values if a module error occurs.

Hold Last State

If the output default is Hold Last State and user power is present, the channel output holds its last value if:

1. The BIU resets the module.
2. No output data is received from the BIU within the BIU Timeout period.
3. Backplane power is lost.
4. The module's watchdog timer expires.

If either of the last two faults occurs, the default output resolution of the value is reduced from 16 bits to 14 bits.

Outputs will continue to hold their last states until the module receives output data from the BIU or until user power is removed.

8 Point Analog Current-Source Output Module

Predefined Ranges and Custom Scaling

There are three predefined data scaling combinations, plus custom scaling.

Selection	Data Range (Engineering Units) = Output Current (μA)
1	4000 to 20000 = 4000 to 20000 (default)
2	0 to 32000 = 4000 to 20000
3	0 to 32000 = 0 to 20000
none	Custom; scaled by user

During operation, the module converts engineering units into digital values that represent output current.

Scaling

Scaling defines the constant-slope mapping from the value in engineering units sent by the BIU to a channel's output current. The default scaling (selection 1) provides an output current range of 4mA (low span value) to 20mA (high span value) for engineering units values of 4,000 to 20,000. The illustration below represents the default scaling.

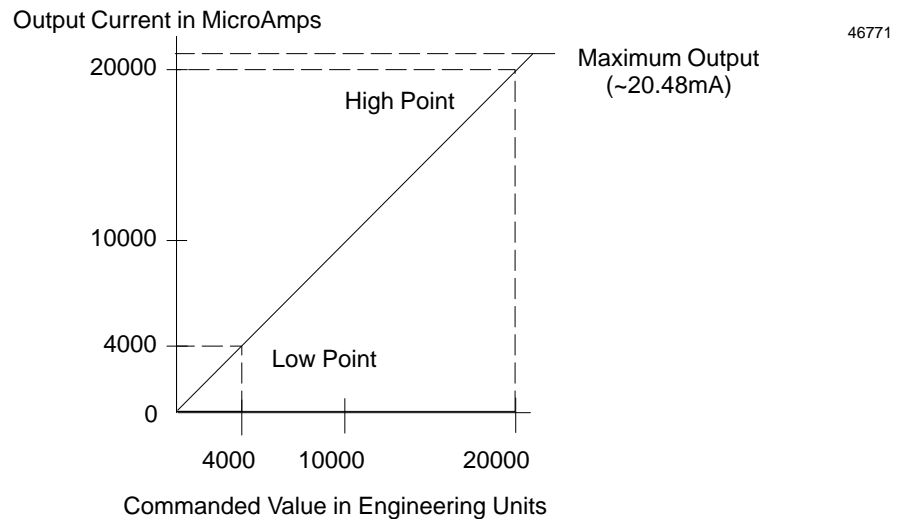

Scaling can be customized by changing any of the engineering units and/or output current values for each point. Span (output current) values are unsigned integers ranging from 0 to 20,000. Engineering units values are 16-bit signed integers from -32,768 to 32,767.

The scaling values selected do not restrict the hardware output range. For example, a channel with default scaling will output current below 4mA for engineering units values below 4,000.

It is possible to choose scaling parameters that actually do limit the current output. For example, associating a low engineering units value of -32,768 with a low span value of 2mA would assure that commanded values below that level would never be received by the module.

8 Point Analog Current-Source Output Module

GFK-1376B
June 1997

Module Specifications

Module Characteristics	
Number of channels (single ended)	8
Power supply range (see note 1)	18 to 30 VDC, 24 VDC typical. 10% maximum ripple
Operating temperature range	0 to 55 degrees C ambient
Isolation to ground and logic	1500 VAC for 1 minute, 250 VAC continuous
Current Drawn from BIU power supply	85 mA maximum
Current Drawn from external power supply	250 mA maximum (with all 8 outputs at 20 mA)
Output Characteristics	
Resolution	16 bits
Magnitude data size	14 bits
Accuracy (see note 4): at 25 C from 0 to +55 C	0.05% typical, 0.1% maximum 0.15%
Output Current Range Limits: 0 to 20 (overrange)	0.0 to 20.48 mA
Analog resolution	0.3125 µA per count, maximum resolution
Output load capacitance	2000 pF maximum
Output load inductance	0.5H maximum
User Load (dependent on temperature and power supply voltage. see notes 2 and 3)	0 to 1250 Ohms
Update time	1.5 mS typical
Open wire output current threshold	1.0 mA minimum, 3.5 mA maximum

note 1: External power supply maximum voltage is dependent on temperature and user load.

note 2: Thermal (operating temperature) and user load derating curves apply. See below.

note 3: $(V_{user} - 5VDC) / 20 \text{ mA} = R_{L(max)}$

note 4: In the presence of severe RF interference (IEC 801-3, 10V/m), accuracy may be degraded to ±0.5% tolerance.

Thermal Derating Curves

The chart below shows the minimum load in ohms at temperatures from 40 degrees to 55 degrees Celsius for user input power supply voltages of 18V, 24V, and 30V. If output load impedance is less than the minimum required, additional series resistance must be added.

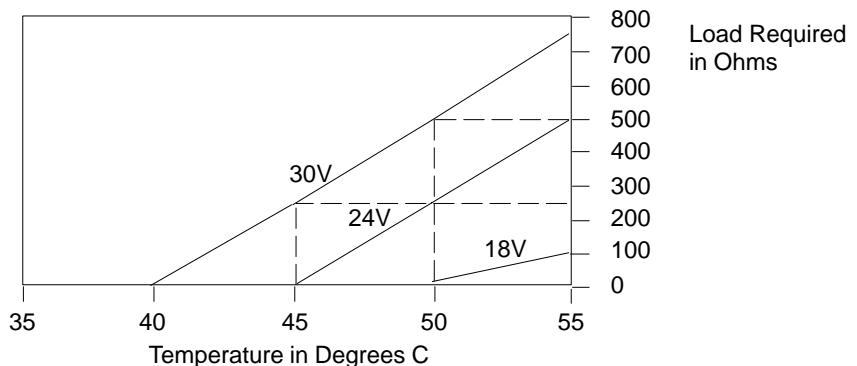

8 Point Analog Current-Source Output Module

Field Wiring

Instrumentation grade Shielded Twisted Pair wire should be used for best noise immunity. The shield should be terminated at a local panel ground near the module. The following illustration shows typical connections for this module.

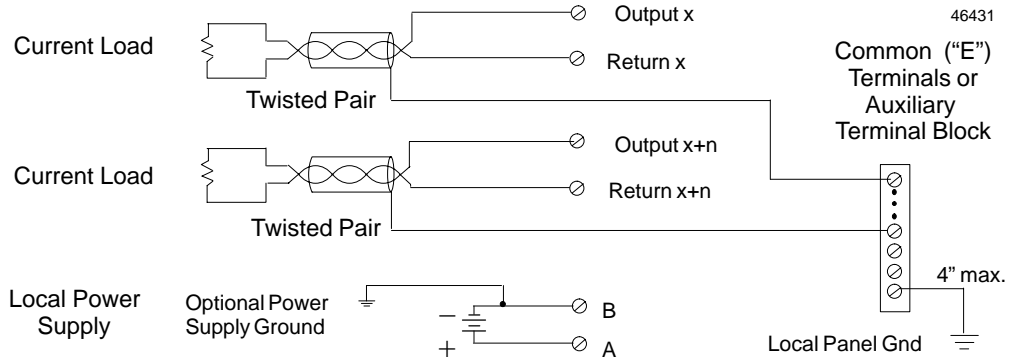

An Auxiliary Terminal Block can be used to provide additional wiring terminals for the shields. Auxiliary Terminal Blocks have all terminals connected together internally. The Auxiliary Terminal Block with box terminals (IC670ACC002) has 13 terminals; each accommodates one AWG #14 (avg 2.1mm² cross section) to AWG #22 (avg 0.36mm² cross section) wire. The Auxiliary Terminal Block with barrier terminals (IC670ACC001) has nine terminals; each can accommodate one or two wires up to AWG #14 (avg 2.1mm² cross section).

I/O Terminal Block Terminal Assignments

An Terminal Block with Box Terminals has 25 terminals per module. Each accommodates one AWG #14 (avg 2.1mm² cross section) to AWG #22 (avg 0.36mm² cross section) wire, or two wires up to AWG #18 (avg 0.86mm² cross section). If an external jumper is used, single-wire capacity is reduced from AWG #14 (2.10mm²) to AWG #16 (1.32mm²). An I/O Terminal Block with Barrier Terminals has 18 terminals per module. Each terminal can accommodate one or two wires up to AWG #14 (avg 2.1mm² cross section). An I/O Terminal Block with Connectors has one 20-pin male connector per module.

All Return terminals are common to each other.

I/O Terminal Block with Box Terminals (IC670CHS002 and 102)	I/O Terminal Block with Barrier Terminals (IC670CHS001 and 101)	I/O Terminal Block with Wire to Board Connectors (IC670CHS003 and 103)																																																																																																																																				
<table border="0"> <tr><td>Return 8</td><td>16</td><td>15</td><td>Output 8</td></tr> <tr><td>Return 7</td><td>14</td><td>13</td><td>Output 7</td></tr> <tr><td>Common</td><td>E8</td><td></td><td></td></tr> <tr><td>Return 6</td><td>12</td><td>11</td><td>Output 6</td></tr> <tr><td>Return 5</td><td>10</td><td>9</td><td>Output 5</td></tr> <tr><td>Common</td><td>E6</td><td></td><td></td></tr> <tr><td>Return 4</td><td>8</td><td>7</td><td>Output 4</td></tr> <tr><td>Return 3</td><td>6</td><td>5</td><td>Output 3</td></tr> <tr><td>Common</td><td>E4</td><td></td><td></td></tr> <tr><td>Return 2</td><td>4</td><td>3</td><td>Output 2</td></tr> <tr><td>Return 1</td><td>2</td><td>1</td><td>Output 1</td></tr> <tr><td>Common</td><td>E2</td><td></td><td></td></tr> <tr><td>DC-</td><td>B2</td><td>A2</td><td>DC+</td></tr> <tr><td>DC-</td><td>B1</td><td>A1</td><td>DC+</td></tr> </table>	Return 8	16	15	Output 8	Return 7	14	13	Output 7	Common	E8			Return 6	12	11	Output 6	Return 5	10	9	Output 5	Common	E6			Return 4	8	7	Output 4	Return 3	6	5	Output 3	Common	E4			Return 2	4	3	Output 2	Return 1	2	1	Output 1	Common	E2			DC-	B2	A2	DC+	DC-	B1	A1	DC+	<table border="0"> <tr><td>Return 8</td><td>16</td><td>15</td><td>Output 8</td></tr> <tr><td>Return 7</td><td>14</td><td>13</td><td>Output 7</td></tr> <tr><td>Return 6</td><td>12</td><td>11</td><td>Output 6</td></tr> <tr><td>Return 5</td><td>10</td><td>9</td><td>Output 5</td></tr> <tr><td>Return 4</td><td>8</td><td>7</td><td>Output 4</td></tr> <tr><td>Return 3</td><td>6</td><td>5</td><td>Output 3</td></tr> <tr><td>Return 2</td><td>4</td><td>3</td><td>Output 2</td></tr> <tr><td>Return 1</td><td>2</td><td>1</td><td>Output 1</td></tr> <tr><td>DC-</td><td>B</td><td>A</td><td>DC+</td></tr> </table>	Return 8	16	15	Output 8	Return 7	14	13	Output 7	Return 6	12	11	Output 6	Return 5	10	9	Output 5	Return 4	8	7	Output 4	Return 3	6	5	Output 3	Return 2	4	3	Output 2	Return 1	2	1	Output 1	DC-	B	A	DC+	<table border="0"> <tr><td>Return 8</td><td>11</td><td>10</td><td>Return 5</td></tr> <tr><td>Output 8</td><td>12</td><td>9</td><td>Output 5</td></tr> <tr><td>Return 7</td><td>13</td><td>8</td><td>Return 4</td></tr> <tr><td>Output 7</td><td>14</td><td>7</td><td>Output 4</td></tr> <tr><td>Return 6</td><td>15</td><td>6</td><td>Return 3</td></tr> <tr><td>Output 6</td><td>16</td><td>5</td><td>Output 3</td></tr> <tr><td>DC+</td><td>A2</td><td>4</td><td>Return 2</td></tr> <tr><td>DC+</td><td>A1</td><td>3</td><td>Output 2</td></tr> <tr><td>DC-</td><td>B2</td><td>2</td><td>Return 1</td></tr> <tr><td>DC-</td><td>B1</td><td>1</td><td>Output 1</td></tr> </table>	Return 8	11	10	Return 5	Output 8	12	9	Output 5	Return 7	13	8	Return 4	Output 7	14	7	Output 4	Return 6	15	6	Return 3	Output 6	16	5	Output 3	DC+	A2	4	Return 2	DC+	A1	3	Output 2	DC-	B2	2	Return 1	DC-	B1	1	Output 1
Return 8	16	15	Output 8																																																																																																																																			
Return 7	14	13	Output 7																																																																																																																																			
Common	E8																																																																																																																																					
Return 6	12	11	Output 6																																																																																																																																			
Return 5	10	9	Output 5																																																																																																																																			
Common	E6																																																																																																																																					
Return 4	8	7	Output 4																																																																																																																																			
Return 3	6	5	Output 3																																																																																																																																			
Common	E4																																																																																																																																					
Return 2	4	3	Output 2																																																																																																																																			
Return 1	2	1	Output 1																																																																																																																																			
Common	E2																																																																																																																																					
DC-	B2	A2	DC+																																																																																																																																			
DC-	B1	A1	DC+																																																																																																																																			
Return 8	16	15	Output 8																																																																																																																																			
Return 7	14	13	Output 7																																																																																																																																			
Return 6	12	11	Output 6																																																																																																																																			
Return 5	10	9	Output 5																																																																																																																																			
Return 4	8	7	Output 4																																																																																																																																			
Return 3	6	5	Output 3																																																																																																																																			
Return 2	4	3	Output 2																																																																																																																																			
Return 1	2	1	Output 1																																																																																																																																			
DC-	B	A	DC+																																																																																																																																			
Return 8	11	10	Return 5																																																																																																																																			
Output 8	12	9	Output 5																																																																																																																																			
Return 7	13	8	Return 4																																																																																																																																			
Output 7	14	7	Output 4																																																																																																																																			
Return 6	15	6	Return 3																																																																																																																																			
Output 6	16	5	Output 3																																																																																																																																			
DC+	A2	4	Return 2																																																																																																																																			
DC+	A1	3	Output 2																																																																																																																																			
DC-	B2	2	Return 1																																																																																																																																			
DC-	B1	1	Output 1																																																																																																																																			
<p>Terminals E1, E2, E4, E6, and E8 are electrically connected together, A1 and A2 are electrically connected together, B1 and B2 are electrically connected together.</p>		<p>46773</p>																																																																																																																																				

8 Point Analog Current-Source Output Module

GFK-1376B
June 1997

Diagnostics Data

The 8 Point Analog Current-source Output Module performs diagnostics and provides 32 bits (4 bytes) of diagnostic data to the BIU. Data is placed in the BIU's discrete input (I) data table starting at the configured reference. The module sets the appropriate bit of this data when a diagnostic condition is detected. Diagnostics bits remain set until cleared by the appropriate data outputs, as described below. The condition causing the fault must be corrected, or the module will set the bit again.

Use of this data is optional. The module is easily configured to use all, some, or none of the diagnostic data.

Module Diagnostics Bits (byte 0)

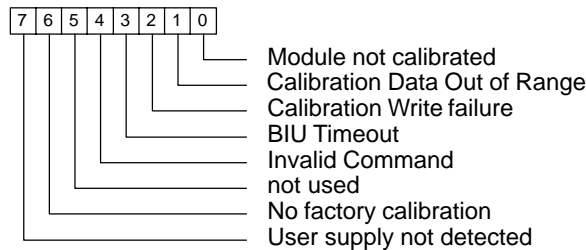

Channel Under/Overrange Bits (byte 2)

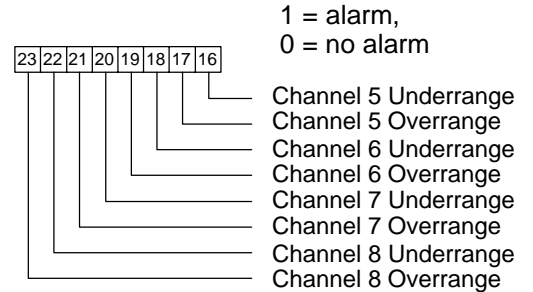

Channel Under/Overrange Bits (byte 1)

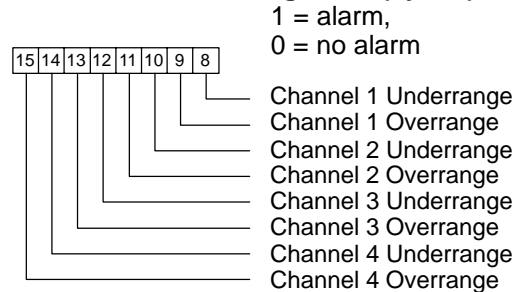

Channel Open Wire Bits (byte 3)

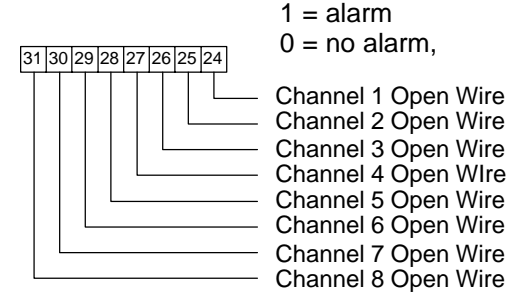

8 Point Analog Current-Source Output Module**Clearing Faults and Alarms**

The BIU uses two bytes of discrete output data to clear the module fault and alarm bits. The fault-clearing bits start at the module's configured discrete output reference in the BIU's discrete output (Q) table.

Setting a bit in the first byte of discrete output data to 1 clears the over/underrange and open wire alarms for the corresponding channel (even if the alarm conditions are still present).

The first two bits of the next byte can be used to clear module diagnostics (byte 0) bit #7 ("User supply not detected") and bit #3 ("BIU Timeout").

Bits #0-2, 4, and 6 in the module diagnostics byte are calibration-related and should never be set during normal operation. These bits cannot be cleared using discrete output (Q) data. If any of these bits is set during normal operation (not during calibration), a problem exists and the module should be returned.

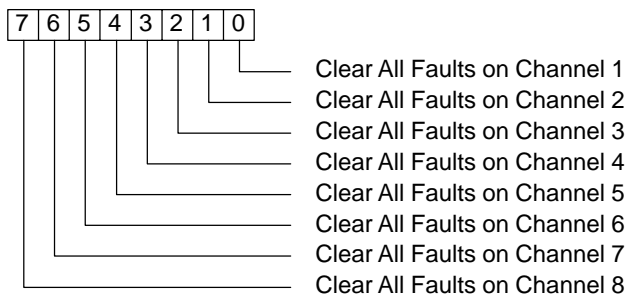
Output Command Bits to Clear Alarms (byte 0)**byte 1**