



Series Six Plus Programmable Controller

GI?K-0147B

June 1989

Central Processor Unit

8-Slot Rack

11-Slot Rack

General Description

The Central Processor Unit (CPU) for the Series Six Plus Programmable Logic Controller (PLC) contains a power supply, three control modules and a memory module, connected to a common backplane and enclosed within a mountable rack. The Series Six CPU rack is available in 2 sizes: 8 slots and 11 slots. The 8 slot rack contains an I/O backplane capable of supporting up to four I/O modules. The 11 slot rack contains an I/O backplane capable of supporting up to seven I/O modules. Three items must be ordered to make up a complete Series Six Plus CPU: (1) a basic unit which includes a rack with power supply, I/O Control module, Arithmetic Control module, ribbon cable, and field wiring trough, (2) Logic Control module, (3) Combined Memory module. The features and benefits of the Series Six Plus PLC are summarized in table 1.

Two of the three control modules, the Arithmetic Control and Logic Control modules, perform the central processing operations of the Series Six Plus Programmable Logic Controller. The Arithmetic Control module contains a 16-bit processor that performs all PLC arithmetic and logical operations. The Logic Control module provides Advanced, Expanded, and Expanded II functions to the processor as well as control and timing signals throughout the CPU.

The third control module, the I/O Control module, provides an interface between the CPU and an input/output (I/O) chain (containing up to 8000 inputs and 8000 outputs), and the Workmaster computer.

With an optional Auxiliary I/O module, an additional 8000 inputs and 8000 outputs can be included on the Auxiliary I/O chain.

The entire Series Six Plus PLC memory system is contained on a single, battery-backed, CMOS memory board, which is the Logic Memory module. This

module contains three types of memory: Internal memory, Register memory and Logic memory. The Internal memory consists of various internal data stored in Table and Scratchpad formats; the Register memory contains storage for up to 16K of 16-bit registers. The user program, which is developed in the Workmaster computer and consists of ladder diagram logic and/or mnemonic functions, is stored in the Logic memory. A Series Six Plus PLC can contain up to 64K of Logic memory.

The CPU can operate in one of two modes: STOP or RUN. In the STOP mode, the CPU performs a series of execution sequences during which the CPU communicates with various system peripherals and executes housekeeping routines.

In the RUN mode, the Series Six Plus CPU solves the user program in logic memory, scans the inputs and updates the outputs, and performs the operations executed in the STOP mode.

A Series Six Plus PLC option, the Communications Control module, allows the Series Six Plus to communicate with intelligent devices (host computer, programmable terminal, etc.) as well as the STR-LINK IIA and STR-LINK III recorders, and Series One, Series Three and Series Six PLCs.

Programs are entered, edited and monitored with the Workmaster computer using Logicmaster 6 programming software.

An IBM PC, PC-XT, or PC-AT personal computer using the unbundled version of Logicmaster 6 software can also be used for the programming functions.

Refer to table 2 for Series Six Plus PLC specifications.

Table 1. FEATURES AND BENEFITS

FEATURES	BENEFITS
Battery-backed CMOS memory: 4K, 8K, 16K, 32K or 64K of Logic Memory 1K to 16K (16-bit words) of Register Memory Table and Scratchpad Memory	Provides ample program storage; allows user to monitor and control I/O and Series Six Plus PLC. All logic memory is available to the user ladder program.
I/O Control module. Auxiliary I/O module	Supports up to 16K input and 16K output (8K I/O in Main chain, 8K I/O in Auxiliary chain) points with I/O Transmitter modules and optional Auxiliary I/O module.
Communications Control modules (option@): CCM2, CCM3, I/O CCM RS-232C Current Loop RS-422	Provides ease and flexibility in operation of Series Six Plus PLC, Two independent ports. Can be Master/Slave without other hardware.
Interface to Workmaster computer.	Expandability in programming capabilities.
Available in three versions to cover 95 to 260 V ac, 50/60 Hz, 24 V dc or 125 V dc source input power without modification,	Can be used in a variety of installations. No jumpers or rewiring required.
Compact size for 64K Logic memory, 16K register memory and up to 224 I/O points in one 19 inch rack.	Easy one rack installation for I/O and CPU capabilities.
GEnet™ Factory LAN for broader communications capabilities than with the Communications Control Modules.	Provides a 10 M bps token passing bus for high speed communications between GE Fanuc automation equipment. Uses the International Standards Organizations' Open System Interconnection model as its communication architecture and complies with the General Motors' Manufacturing Automation Protocol (MAP) specification which includes the IEEE 802.4 token bus standard.

GFK-0147B

a42334

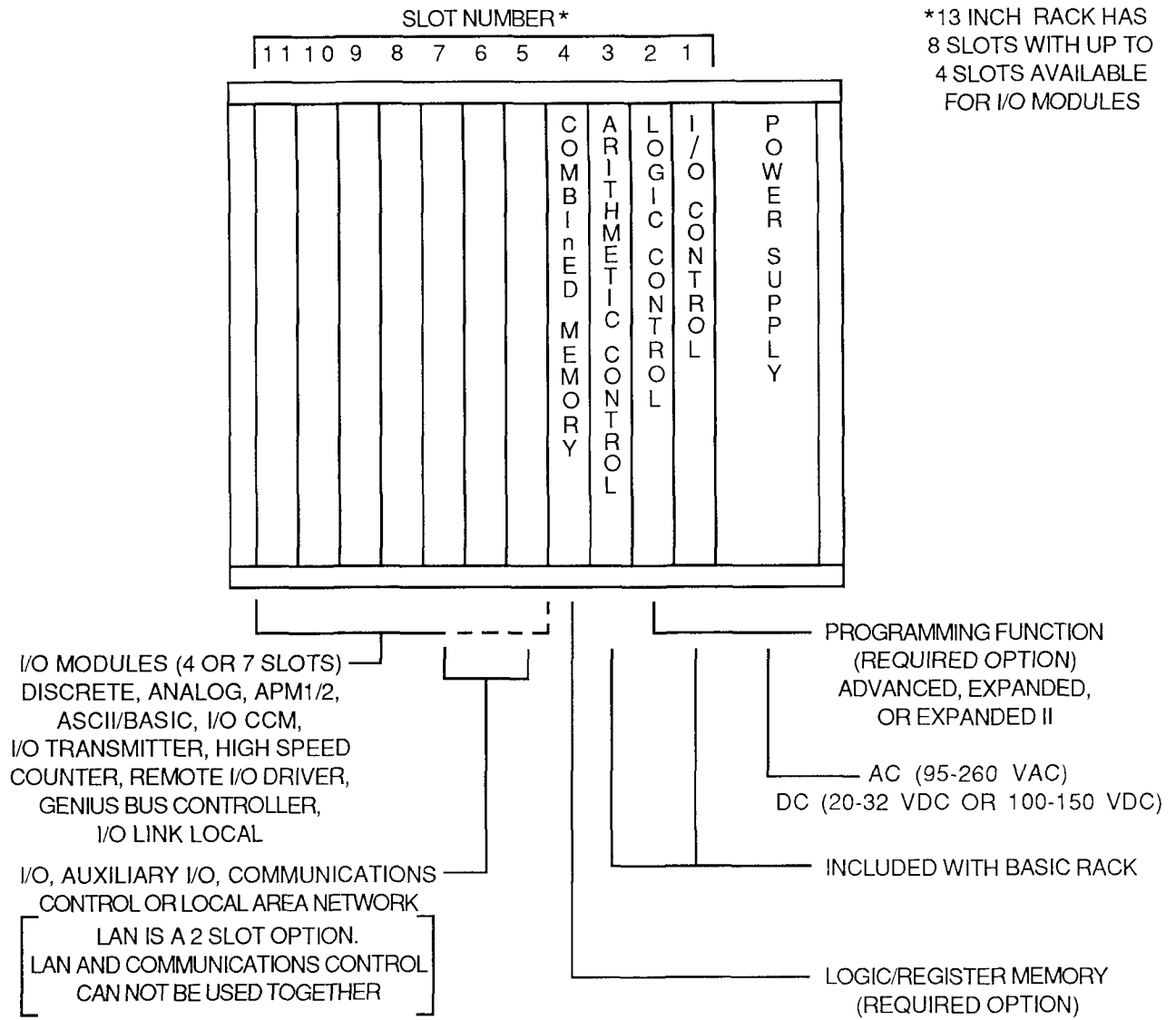

Figure 1. CPU RACK CONFIGURATION

a42259

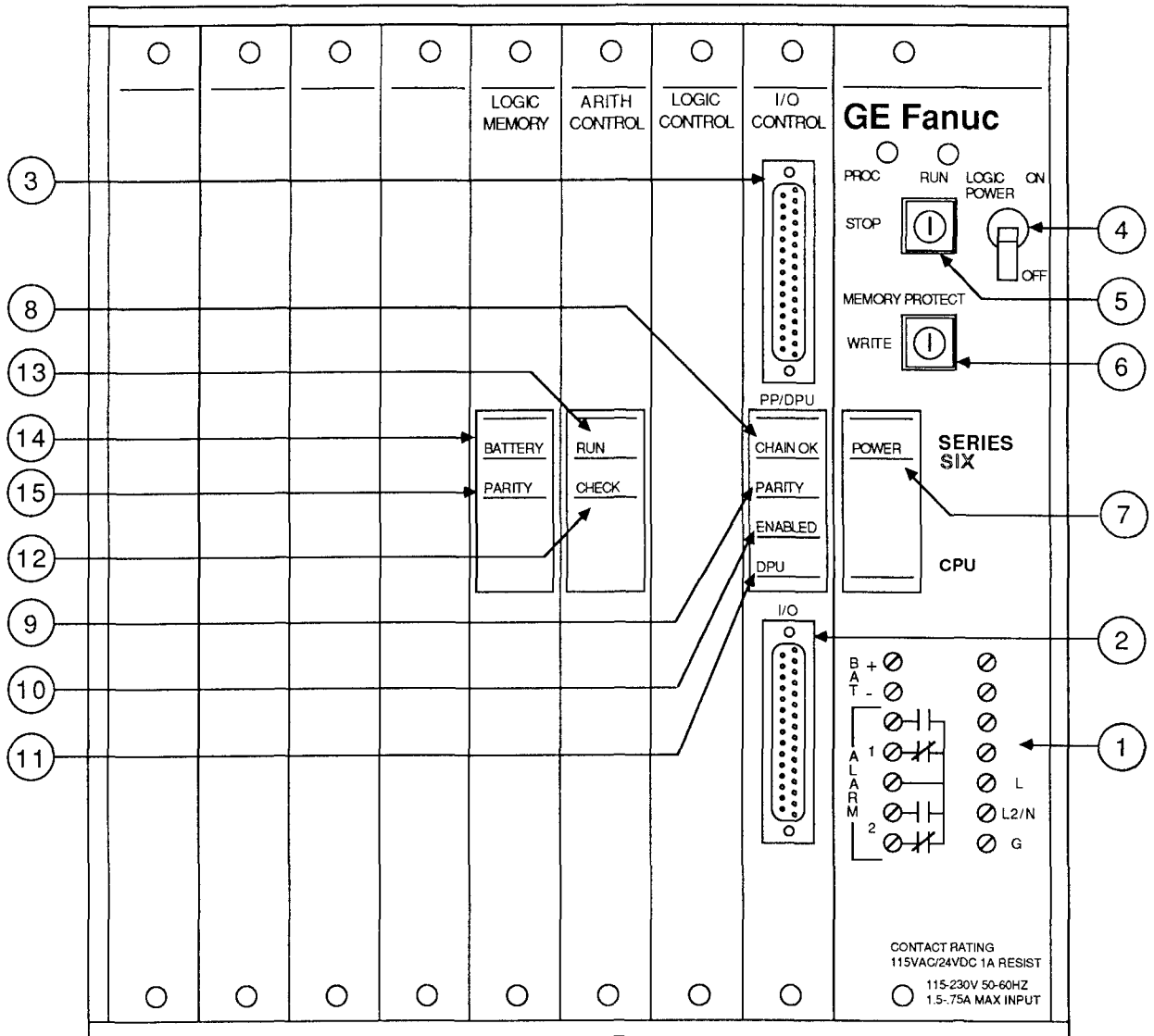

Figure 2. SERIES SIX PLUS CPU RACK USER ITEMS

GFK-0147B

1. Power-Supply Front-Panel Connector Block.
2. D-Type 36-Pin Connector to I/O Chain.
Connects to I/O Receiver or Advanced I/O Receiver module in nearest I/O rack in chain.
3. D-Type 36-Pin Connector to Workmaster computer.
4. Power Switch
5. CPU RUN/STOP Key Switch
STOP: CPU is unconditionally in the STOP mode.
RUN: CPU is in the RUN mode, unless this condition has been altered by commands from the Workmaster computer, or by the state of various control signals. When this switch is turned from STOP to RUN, the system starts when the outputs are enabled.
6. MEMORY PROTECT Key Switch
PROTECT: The contents of the Logic Memory and the Override Table are protected from being changed.
WRITE: The user program in the Logic Memory can be changed, and an override condition can be added to or removed from inputs or outputs through the Override Table.
7. POWER Light
On: The voltage levels of all three DC outputs (+12V, -12V, +5V) are within tolerance.
Off: At least one of these voltage levels is out of tolerance.
8. CHAIN OK Light
On: Continuity, power, and output data parity are OK at all I/O stations in the chain.
Off: A continuity, or power problem, or output data parity error exists at one of more I/O stations(s).
9. PARITY Light
On: Input data parity is OK at the I/O Control module.
Off: Input data parity error exists.
10. ENABLED Light
On: Outputs are enabled. CPU is operating in the RUN ENABLED mode.
Off: Outputs are disabled. CPU is in the RUN DISABLED or the STOP mode.
11. DPU Light
On: Data Processor is OK.
Off: A continuity error or other type of problem exists with the DPU. Also off if no DPU is connected.
12. CHECK Light
On: CPU execution sequence is proceeding and the self-test has passed at least once each 300ms (+/- 50 ms). CPU can be in RUN or STOP mode.
Off: CPU self-test has not been passed within 300 ms (+/- 50 ms). CPU goes to STOP mode: I/O chain is reset.
13. RUN Light
On: CPU execution sequence is proceeding and the self-test has passed at least once each 300ms (+/- 50 ms). CPU is in RUN mode.
Off: CPU is in STOP mode.
14. BATTERY Light
Steady On: Battery Normal
Flashing: Battery Low - CPU continues running. No. 2 alarm is activated. To protect the memory contents, the battery should be replaced before it fails.
Steady Off: Battery Failed - CPU continues running, but will not restart if stopped. No. 2 alarm remains activated. Memory contents will be lost when power is switched off or lost.
15. PARITY Light
On: Table, Register and Logic memory parity is OK.
Off: Parity error exists in either Table, Register or Logic memory. An error message identifying location of the error will appear in the scratchpad display area on the Workmaster computer screen.

Installation

This section provides a summary of the procedures described in Chapter 3 of the Series Six Plus User's Manual (GEK-96602). Do not attempt to install the Series Six Plus PLC without consulting that manual.

1. The Series Six Plus PLC can be rack, panel or wall mounted, depending on the position of the mounting brackets. **IMPORTANT:** Proper safety ground and signal ground connections must be made as described in the Series Six Plus User's Manual.
2. Connect the Lithium-Manganese Dioxide battery to either of the male jacks beneath the battery on the Logic Memory module.
3. Install the Logic Control module in slot 2, which is to the left of the I/O Control module. Use the extraction/insertion tool supplied with the basic CPU unit to insert (or remove) this module (or any other module) into the Series Six Plus rack.
4. Install the Logic Memory module in slot 4, which is to the immediate left of the Arithmetic Control module. Use the extraction/insertion tool supplied with the CPU to insert this module into the Series Six Plus rack.
5. Set the jumpers on the I/O Control module according to system requirements.
6. Make the following connections to the terminal block on the Series Six Plus PLC power supply:
 - 3-wire (grounding) AC power cord for AC power supply
 - DC source connections to POS and NEG terminal for DC power supply.
 - Alarm relay contacts (optional)
 - Auxiliary battery (optional)
 - Install the protective cover plate after making these connections.
 - Connect the cable from the primary I/O chain to the lower faceplate connector on the I/O Control module. Connect the cable from the Workmaster computer or Program Development Terminal to the upper connector (Workmaster required with Expanded functions). If neither the Workmaster computer nor the PDT is to be connected, the upper connector can be left empty.

NOTE

After a power fault, the system comes back in the mode (STOP, RUN ENABLED, or RUN DISABLED) in which it was operating before power was lost.

Both the RUN and the CHECK indicator can flash momentarily when power is turned on in the CPU. A valid RUN or CHECK state, however, is indicated by a steady glow of the LED.

See outline drawings of racks on pages 7-10.

a43009

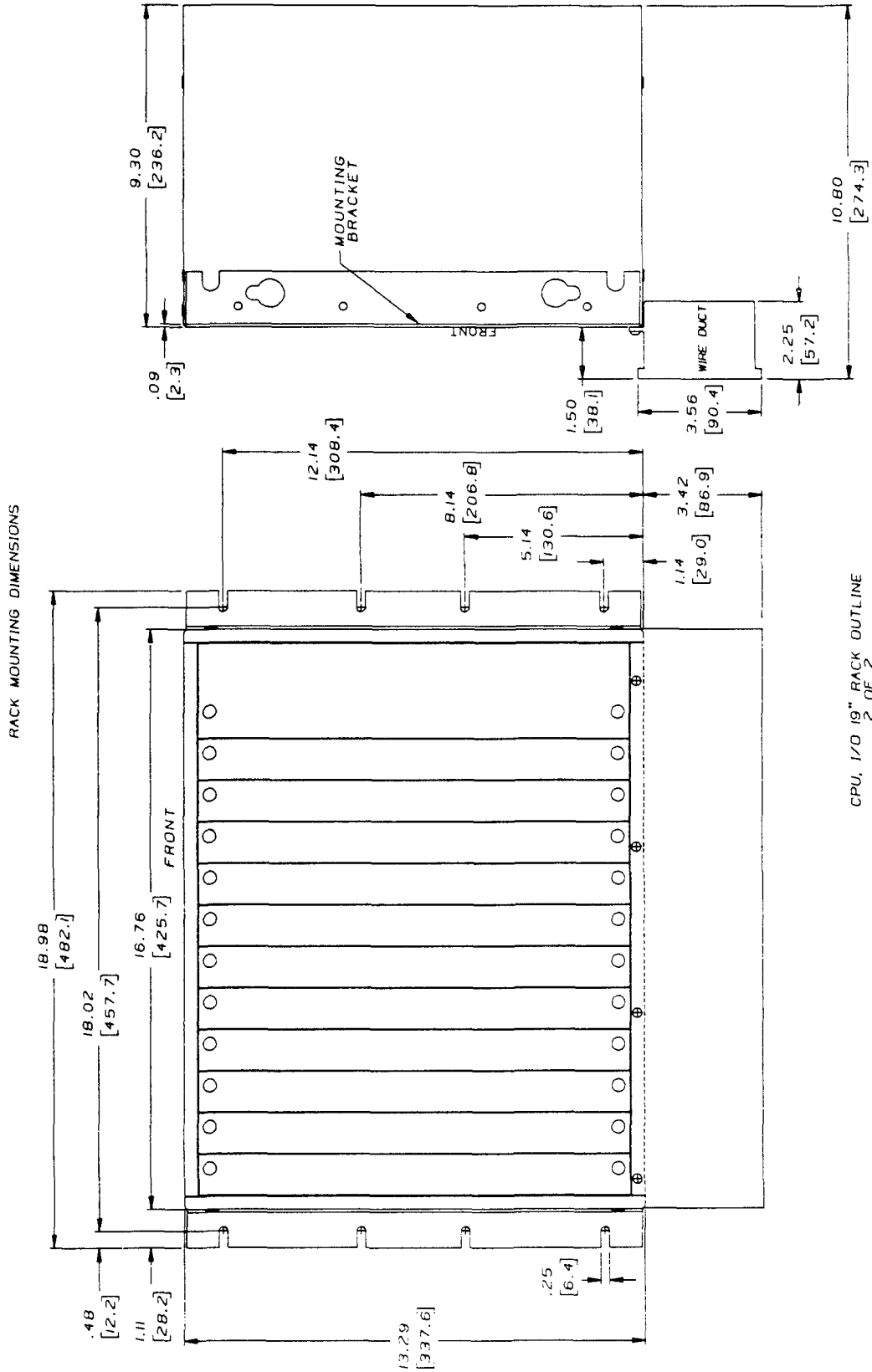

CPU, 1/0 19" RACK OUTLINE
2 OF 2

GFK-0147B

Table 2. SPECIFICATIONS

Dimensions (19", 11 slots):	
Rack-Mount	19.0(W) x 13.4(H) x 9.3(D) inches (483 x 340 x 236 millimeters)
Panel Mount	20.0(W) x 13.4(H) x 9.3(D) inches (508 x 340 x 236 millimeters)
Dimensions (13", 8 slots):	
Rack-Mount	16.0(W) x 13.4(H) x 9.3(D) inches (406 x 340 x 236 millimeters)
Panel Mount (Brackets on sides)	16.0(W) x 13.4(H) x 9.3(D) inches (406 x 340 x 236 millimeters)
Panel Mount (Brackets on Top and Bottom, Side by Side Mount)	13.25(W) x 16.15(H) x 9.3(D) inches (340 x 410 x 236 millimeters)
Weight (filled), 11 slot	37 pounds (17 kg)
Storage Temperature	-20 to +70C (-4 to +158F)
Operating Temperature	0 to +60C (+32 to +140F) outside of rack
Humidity	5% to 95% (non-condensing)
Power Requirements	Three power supplies are available: <ul style="list-style-type: none"> 1. 95-260 V ac 47-63 Hz 250VA Max. 2. 20-32 V dc 180 watts Max. 3. 100-150 V dc 200 watts Max.
Allowable Power Interruptions	33 ms minimum at 115 V ac line 10 ms minimum at 20 V dc 4 ms minimum at 100 V dc
Noise Immunity	Meets requirements of NEMA ICS 2-230 and ANSI C 37.90A
Memory Configuration (16.bit words)	5K total: 4K Logic Memory and 1K register Memory 12K total: 4K Logic Memory and 8K Register Memory 16K total: 8K Logic Memory and 8K Register Memory 24K total: 16K Logic Memory and 8K Register Memory 48K total: 32K Logic Memory and 16K Register Memory 80K total: 64K Logic Memory and 16K Register Memory
Input Capacity maximum	16000 points when in Expanded I/O mode
Output Capacity maximum	16000 points when in Expanded I/O mode

Basic unit includes rack, power supply, I/O Control module, Arithmetic Control module, ribbon cable (connects Arithmetic Control to Logic Control), module extraction/insertion tool, mounting brackets, I/O termination plug, and field wiring trough.

Table 3. ORDERING INSTRUCTIONS

DESCRIPTION				CATALOG NUMBER
<u>Series Six Plus CPU</u>				
with 95 to 260 V ac Power Supply, 11 slot				IC600CP630
with 24 V dc Power Supply, 11 slot				IC600CP634
with 125 V dc Power Supply, 11 slot				IC600CP635
with 95 to 260 V ac Power Supply, 8 slot				IC600CP610
with 24 V dc Power Supply, 8 slot				IC600CP612
with 125 V dc Power Supply, 8 slot				IC600CP615
<u>Logic Control Module (select one)</u>				
Advanced Functions				IC600CB525
Expanded Functions				IC600CB526
Expanded II Functions				IC600CB5 15
<u>Memory Options</u>				
	Total User	Logic	Register	
	Memory	Memory		
<u>Memory</u>				
	5 K	4 K	1K	IC600LX605
	12K	4 K	8K	IC600LX612
	16 K	8K	8 K	IC600LX616
	24K	16K	8 K	IC600LX624
	48K	32K	16 K	IC600LX648
	80K	64K	16K	IC600LX680
<u>Renewal Part</u>				
Series Six Plus CPU	8-slot rack without		power supply	IC600CR610
Series Six Plus CPU	11-slot rack without		power supply	IC600CR620



This symbol on the nameplate means the product is listed by Underwriters Laboratories Inc. (UL Standard No. 508, Industrial Control Equipment, subsection Electronic Power Conversion Equipment.)

For further information, contact your local GE Fanuc North America Distributor or sales office.