

Barrier-Style I/O Carrier

October 1999

GFK-1555A

Description

The Barrier-Style I/O Carrier has 36 barrier-style terminals for field wiring. It provides mounting, backplane communications, and field wiring for one I/O module.

Module Compatibility

Barrier-style Carrier version B and later is compatible with all I/O module types. Barrier-style Carrier version A should not be used with the following I/O module types:

- 240VAC Isolated Input Module, 4 Point
- 240VAC Isolated Input Module, 8 Point
- 240VAC Isolated Input (4 Pt) / Relay Output (8 Pt) Mixed Module

Preinstallation Check

Carefully inspect all shipping containers for damage. If any equipment is damaged, notify the delivery service immediately. Save the damaged shipping container for inspection by the delivery service. After unpacking the equipment, record all serial numbers. Save the shipping containers and packing material in case it is necessary to transport or ship any part of the system.

Clearance and Orientation

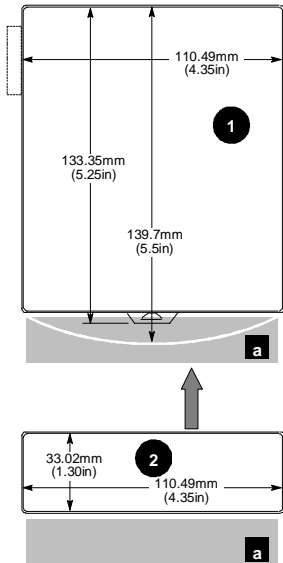

Carriers must be mounted on a horizontal DIN rail.

1. **Barrier-Style I/O Carrier**
 - a. Allow adequate space for I/O wiring.
2. **Auxiliary I/O Terminals (optional)**
 - a. Allow adequate space for device wiring. Multiple Auxiliary Terminals may be used to provide additional wiring terminals

The carrier with module attached fits into a 70mm deep enclosure.

Rated thermal specifications are based on a clearance 2 inches (5.1cm) above and below the equipment and 1 inch (2.54cm) on each side of the assembled equipment.

Installing the Carrier on the DIN Rail

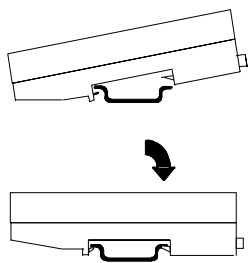

All connecting carriers must be installed on the same section of 35mm x 7.5mm DIN rail. The rail must have a conductive (unpainted) finish for proper grounding. For best stability, the DIN rail should be installed on a panel using screws spaced approximately 6 inches (5.24cm) apart.

The carrier snaps easily onto the DIN rail. No tools are required for mounting or grounding to the DIN rail.

Removing the Carrier from the DIN Rail

1. Turn off power to the power supply.
2. (If the carrier is attached to the panel with a screw) remove the panel-mount screw.
3. Slide the carrier away from the other carriers until the connectors on both sides disengage from the adjacent carriers.
4. With a small flathead screwdriver, pull the DIN rail latch outward while tilting the other end of the carrier down to disengage it from the DIN rail.

Panel-Mounting

If excessive vibration is a factor the carrier should also be screwed down to the mounting panel.

Note 1. Tolerances are +/- 0.13mm (0.005in) non-cumulative.

Note 2. 1.1-1.4Nm (10-12 in/lbs) of torque should be applied to M3.5 (#6-32) steel screw threaded into material containing internal threads and having a minimum thickness of 2.4mm (0.093in).

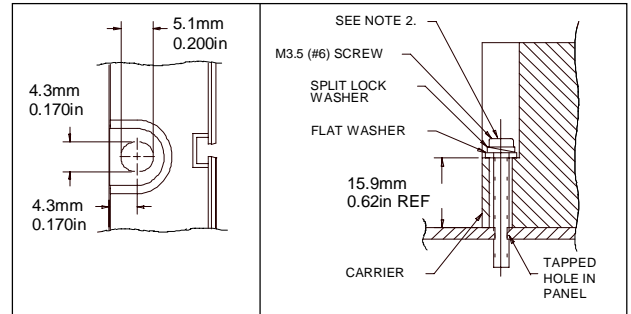

Field Wiring Terminals

Each terminal accommodates one or two solid or stranded wires from AWG #22 (avg. 0.36mm² cross section) to AWG #14 (avg. 2.1mm² cross section). Use copper wire rated for 90 degrees C. When inserting two wires in the same position, the wires must be the same size and type (solid or stranded).

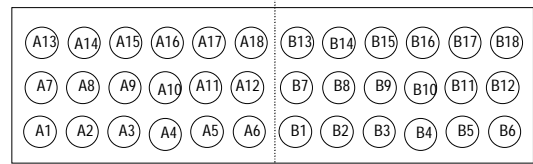

The carrier accommodates current levels up to 2 Amps per point or 8 Amps per each power and ground, and a voltage range of up to 264 VAC. Voltage transients up to 300 VAC will not damage the carrier.

Using Auxiliary I/O Terminals

One or more Auxiliary I/O Terminals can be used to provide extra field wiring connections if needed. Auxiliary I/O Terminals are installed by inserting the tabs into the slots on the I/O carrier and pressing downward. Additional Auxiliary I/O Terminals can be connected together in the same way. Screws can be inserted through the panel-mount holes for added stability if needed.

Auxiliary I/O Terminals have two groups of 6 internally-bussed terminals. There is no electrical connection from the I/O Carrier to the Auxiliary I/O Terminals; any necessary electrical reference must be provided.

Each terminal accommodates one or two solid or stranded wires from AWG #22 (avg. 0.36mm² cross section) to AWG #14 (avg. 2.1mm² cross section). Use copper wire rated for 90 degrees C. When inserting two wires in the same position, the wires must be the same size and type (solid or stranded).

Auxiliary I/O Terminals must be installed before connecting field wiring.

Auxiliary I/O Terminals accommodate current levels up to 8 Amps and voltage up to 264 VAC. Voltage transients up to 300 VAC will not cause damage.

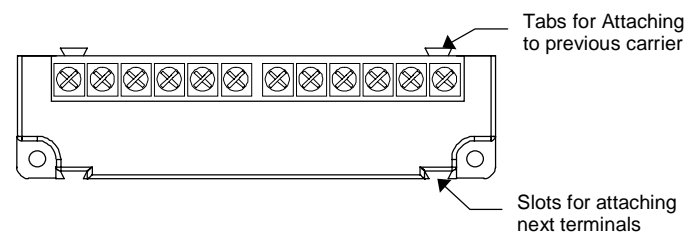

Barrier-Style I/O Carrier

October 1999

GFK-1555A

Using A Shorting Bar

A Shorting Bar is available that may be used instead of an Auxiliary I/O Terminals unit if the I/O module has only one I/O board inside the module housing. A Shorting Bar must be installed *directly on the carrier* in the unused position before installing the I/O module.

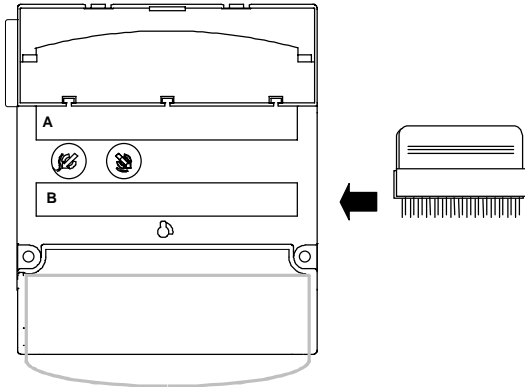

Setting the Carrier Keying

Set the keying dials on the carrier to match the factory keying on the underside of the module. One dial selects alphabetic characters and the other selects numbers.

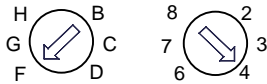

Module Installation

The I/O module mounts vertically (perpendicular to the DIN rail) on the carrier.

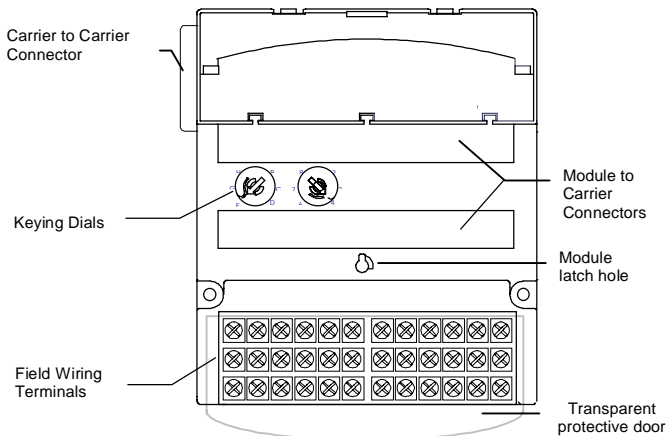

Installing a Module on the Carrier

Note: Before installing a module in an operating system, refer to the information below about Module Hot Insertion and Removal.

The latch on the module must be in the unlocked position as illustrated to install a module on its carrier.

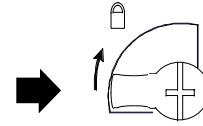

Align the three T-shaped projections on the module side with the slots on the carrier and align the latch post on the module with the hole on the carrier.

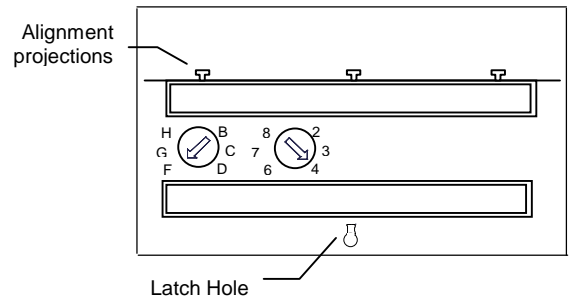

Press the module straight down onto the carrier, seating it fully.

Turn the latch to the locked position to secure the module to the top of the carrier.

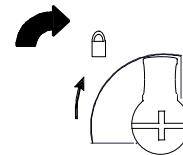

Hot Insertion and Removal of Modules

If external power to a module's field devices is removed, the module itself can be removed/inserted in an operating system (backplane power and CPU or NIU active) without affecting the rest of the system.

Caution

Operating equipment may be very hot, especially at higher ambient temperatures. If the equipment is hot, do not touch it directly.

Such "hot insertion" and removal should not be attempted in hazardous locations. Personal injury, system malfunction and/or damage to the equipment may occur.

This equipment is suitable for use in non-hazardous locations or in Class 1, Div. 2, Groups A, B, C, and D, and Class 1 Zone 2 locations.

Explosion hazard: Substitution of components may impair suitability for Class I, Division 2 and Class 1 Zone 2.