



This Datasheet for the

IC660BBA023

Block 24/48Vdc Thermocouple Input 6 Channels

<http://www.qualitrol.com/shop/p-14418-ic660bba023.aspx>

Provides the wiring diagrams and installation guidelines for this GE Series 90-30 module.

For further information, please contact Qualitrol Technical Support at

1-800-784-9385

support@qualitrol.com

Thermocouple Input Blocks

June 2002

GFK-0055D

Description

Thermocouple Input Blocks are primarily used for monitoring temperature, with standard thermocouple types connected to the inputs. They can also be used for measuring low-level voltage input signals.

Two Thermocouple blocks are available:

- **115 VAC/125 VDC Thermocouple block** (IC66*BBA103)
- **24/48 VDC Thermocouple block** (IC66*BBA023)

They are the same except for the power supply.

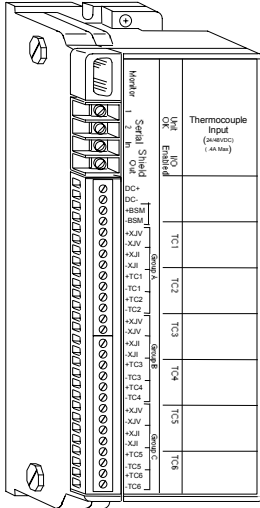

Features

A Thermocouple block has six input circuits, in three isolated groups. ± 10 V common mode voltage (maximum) allowed between 2 points in a group. Each group has two thermocouple input circuits and two remote cold junction compensation inputs. Group to group isolation is 300 volts.

Each input can interface to type J, K, T, E, B, R, S, and N (#14 AWG Nicrosil vs. Nisil) thermocouples. The block provides cold junction compensation for all thermocouple input measurements.

Each channel can be configured to use an internal sensor, an external sensor, or a user-defined value (in the range of ± 327.67 mV) for cold-junction compensation. An external signal from a remote junction can be either a voltage (XJV) or a current (XJI) analog of temperature. The XJV input is scaled for 1.0 mV per degree Centigrade and the XJI input is scaled for 1.0 μ A per degree Kelvin. After compensation, the block linearizes each thermocouple input measurement according to the NBS monograph for the thermocouple type in use.

Each input measurement can be adjusted up to ± 100.0 degrees C or ± 100.0 degrees F for greatest accuracy.

An output is provided to drive a Bus Switching Module (version IC66*BSM021 only).

Thermocouple blocks perform the following diagnostics:

- Internal fault detection
- Open Wire detection
- Overrange and underrange input indication
- High and low input alarms

Specifications

Catalog Numbers

115 VAC/125 VDC Thermocouple Block	IC66*BBA103
Terminal Assembly	IC66*TBA103
Electronics Assembly	IC66*EBA103
24/48 VDC Thermocouple Block	IC66*BBA023
Terminal Assembly	IC66*TBA023
Electronics Assembly	IC66*EBA023

Block Specifications

Size (height x width x depth)	8.83" (22.44cm) x 3.34" (8.48cm) x 3.91" (9.93cm)		
Weight	4 lbs. (1.8 kg)		
LEDs (I/O Block)	Unit OK, I/O Enabled		
Block to Block Isolation	1500V		
Group to Group Isolation	300V		
Heat Dissipation	9W maximum		
Block Power	115VAC	125VDC	24/48VDC
Power supply voltage (@9W)	93 - 132 VAC 47 - 63 Hz	105 - 145 VDC 10% max. ripple	18 - 56 VDC 10% max. ripple
Power supply dropout time	1 cycle	10ms	10ms

Input Specifications

Voltage measurement: Range Resolution	-25.0mV to +150mV Less than ± 4 μ V. Less than ± 10 μ V error typ, ± 20 μ V max.
Accuracy (at 25°C)*	8 Hz
Bandwidth of input amplifier filter	± 2 μ V per °C typical

Internal Cold Junction Measurement:

Range	0 to 60°C
Offset at 25°C	± 2 °C typ. Adjustable to zero at any temperature.
Linearity	± 0.15 °C
Resolution	Less than ± 0.01 °C
Temperature coefficient	± 0.05 ° per °C

External Cold Junction Measurement:

Range	-25.0°C to +150.0 °C
Scale factors	1.0°C per millivolt, 1.0°K per microampere
Resolution	Less than ± 0.01 °C
Accuracy	± 0.1 °C
Input update time (all channels):	2.0 seconds (typ), 3.0 seconds (max)
Open wire detection response:	less than 5.0 seconds
Diagnostics	Open Wire, Overrange, Underrange, High Alarm, Low Alarm, Internal Fault

Refer to GFK-0867 for product standards and general specifications.

* In the presence of severe RF interference (IEC 801-3, 10V/m), accuracy may be degraded to ± 1 (0.5% of full-scale reading plus 0.5% or reading).

Using this Datasheet

This datasheet summarizes information about block installation, configuration, and diagnostics. Your primary reference should be the *Discrete and Analog Blocks User's Manual*. It includes detailed instructions for block installation and configuration. For additional information about systems and communications, including bus specifications, refer to the *I/O System and Communications Manual*.

Thermocouple Input Blocks

June 2002

GFK-0055D

Compatibility

Thermocouple blocks are compatible with:

For an IC697 series PLC, the CPU must be rel. 2 (IC697CPU731 or 771) or later. The Bus Controller must also be: rel 2 (IC697BEM731) or later. The programming software must be rel 2.02 or later.

For an IC600 series PLC, the CPU must be rev. 105 or later. For an IC600 series Plus PLC, the CPU must be rev. 110 or later. The Bus Controller must be model IC66*CBB902 or 903. The programming software must be rel. 4.02 or later.

For an IC550 series PLC, the CPU must be rev. 3.0 or later. The programming software must be rel. 2.01 or later.

Hand-held Monitor model IC66*HHM501D (version 3.5) or later can be used with these blocks. However, HHM version 3.7 or later is required for full configuration capability.

If a Bus Switching Module is connected directly to the block, it must be the 24/48 VDC version (IC66*BSM021).

Installation Instructions

Carefully inspect all shipping containers for damage. If any equipment is damaged, notify the delivery service immediately. Save the damaged shipping container for inspection by the delivery service. After unpacking the equipment, record all serial numbers. Save the shipping containers and packing material in case it is necessary to transport or ship any part of the system.

Block Mounting

Genius I/O blocks are considered "open equipment" and therefore must be installed within a protective enclosure. They should be located in an area that is clean and free of airborne contaminants. There should be adequate cooling airflow.

For best performance, it is recommended that this block be mounted in such a manner as to minimize the change in ambient temperature to which it is exposed.

The block can be mounted right side up, or upside down. Leave at least 2 inches of space between blocks. Mount the block by drilling two screw or bolt holes for 8-32 hardware. Position the block so that the notches in the upper and lower flanges line up with the mounting holes. Mount the block using 8-32 screws. Use star washers to provide ground integrity.

Grounding

The block's mounting screws must not be used as the only means of grounding the block. Connect the green ground screw on the block to a reliable ground system using a short wire lead, minimum size AWG #12 (avg 3.3mm² in cross-section).

WARNING: If mounting screws do not make good ground connection and the ground screw is not connected to a reliable ground, the block is not grounded. Electrical shock hazard exists. Death or personal injury may result.

Removing an Electronics Assembly

The block's Electronics Assembly can be replaced with a compatible model without removing field wiring or reconfiguring the block.

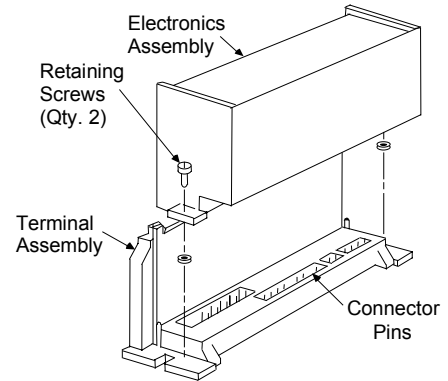

1. Unscrew the retaining screws at the top and bottom of the block.
2. Using a Block Puller (IC660BLM507), engage the tabs in the first vent slots. Move the tool to the center of the block and squeeze the handle.
3. Pull the Electronics Assembly upward.

WARNING: If power is applied to the field terminals, power is also exposed on the connector pins at the base of the Terminal Assembly, and electrical shock hazard exists. Do not touch the connector pins! Death or injury may result.

Inserting an Electronics Assembly

1. Align the Electronics Assembly in the guides and push down firmly.

CAUTION: Do not exert excessive force; it may damage the block.

2. If unusual resistance is met, remove the Electronics Assembly. If power is applied to the block, DO NOT TOUCH THE CONNECTOR PINS! Inspect the Terminal Assembly, connector receptacle, and connector edge board (on the Electronics Assembly). Be sure the keying matches. Remove any obstacles and reinsert the Electronics Assembly. Pay close attention to the alignment of the guide pins.
3. Secure the Electronics Assembly with the screws on the top and bottom of the Terminal Assembly.

Note: If the Electronics Assembly has been removed from a block for some length of time, contaminants may have built up on the exposed connector pins. After the block is reassembled, these contaminants could affect the accuracy of measurements. When reassembling the block, push the Electronics Assembly in and out a few times to assure a fresh mating surface.

Thermocouple Input Blocks

June 2002

GFK-0055D

Block Wiring

Do not overtorque the terminal screws. Recommended torque for all terminals is 6 in/lb (.678 N/M).

Serial Bus Wiring

Using one of the cable types recommended in the *System and Communications User's Manual*, connect the serial bus to terminals 1-4. If a Bus Switching Module will be connected to the block, see below instead.

Terminals 1 to 4 are for the serial bus. These terminals accept one AWG #12 wire (avg 3.3mm² cross-section) or two AWG #14 wires (each avg 2.1mm² in cross-section). The minimum recommended wire size is AWG #22 (avg .36mm² in cross-section).

Terminals 1 - 4 can also accommodate spade or ring terminals up to 0.27 inch (6.85mm) wide with a minimum opening for a #6 screw, and up to 0.20 inch (5.1mm) depth from the screw center to the back barrier. Be sure unshielded wire ends are not longer than 2 inches (5 cm).

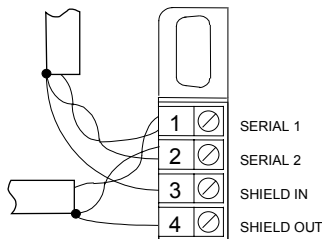

If the block is at either end of the bus, connect a terminating resistor of the appropriate type (see the *System and Communications User's Manual* for details) across its Serial 1 and Serial 2 terminals.

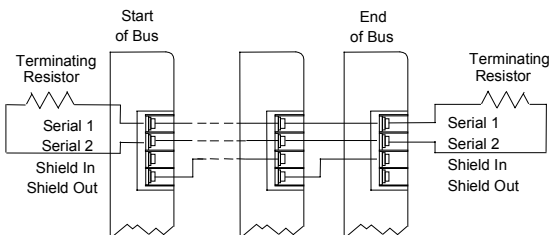

Installing a Bus Switching Module

If a Bus Switching Module will be connected *directly* to the block, install it at the block's serial bus terminals, as shown in the diagram on the next page. Connect the bus cables to the BSM. Connect either of the BSM pigtail wires to terminals 7. Connect the other to terminal 8.

Field Wiring

Terminals 5 to 32 are for field devices. They take a single wire up to AWG #14 (avg 2.1mm² in cross-section). Minimum recommended size is AWG #20 (avg .54mm² in cross-section).

Wiring for Block Power

For block power, connect an appropriate power source to terminals 5 and 6. For the 115 VAC/125 VDC block version, connection can be of either polarity. For the 24/48 VDC version, the polarity should be observed as marked, although protection is provided against accidental reversed input polarity.

Wiring for Thermocouples

Thermocouple wires should be connected to the six channels observing the proper polarity. For American color coding, connect the red wire to the (-) terminal.

For the smaller gauge thermocouple wires, connector-type crimp pins of the same alloy are recommended to make installation easier.

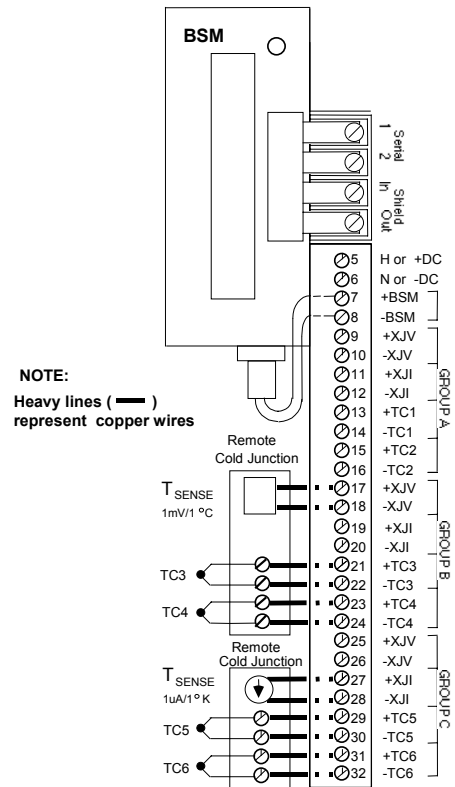

LEDs

The block's Unit OK and I/O Enabled LEDs show its operating status:

Unit OK	I/O Enabled	Meaning
ON	ON	Block functioning, CPU communicating
ON	OFF	Block functioning No CPU communications for 3 bus scans
ON	Blinking	Block functioning, Circuit forced
Blinking	ON	Circuit fault, CPU communicating
Blinking	OFF	Circuit fault No CPU communications for 3 bus scans
Alternate Blinking		Circuit fault, Circuit forced
Synchronous Blinking		No CPU communications - block number conflict
OFF	Blinking	Electronics/Terminal Assembly mismatch
OFF	OFF	No block power, or block faulty

Thermocouple Input Blocks

June 2002

GFK-0055D

Block Operation

A Thermocouple Input Block has three isolated pairs of inputs. Transformers isolate power and optical couplers provide signal isolation.

For each pair of inputs:

1. After filtering, each signal input is sequentially switched into a common amplifier whose output is applied to a voltage to frequency converter. The output signal frequency of the VFC is applied to a frequency counter via an optical coupler. The output frequency is counted for a 400 millisecond gate time, which provides rejection of line frequency pickups.
2. The multiplexer intersperses other inputs between the two main thermocouple input times. These other inputs come from the cold junction sensors and from internal references. The cold junction inputs are measured and stored for later compensation of the normal thermocouple input measurement errors.
3. To detect and correct for any gain or offset drift in the amplifier or VFC, the block takes new readings of factory-calibrated internal reference levels during operation. These new measurements are compared to reference values stored by the block.
4. The processor converts the cold junction temperature value to a voltage for the thermocouple type in use. This voltage is then added to the thermocouple measurement before converting to thermal units. To compensate for small differences between the cold junction temperature measurement and the actual cold junction temperature, an offset adjustment can be entered using a Handheld Monitor.

Diagnostics

Block diagnostics are listed below. Fault messages can be cleared from the Hand-held Monitor or the CPU.

High Alarm: Input over its high alarm limit

Low Alarm: Input under its low alarm limit

Open Wire: Missing or faulty connection to a thermocouple input, XJV input, or XJI input.

Overrange or Underrange: Reported only if engineering units of degrees are selected. Indicates one of the following conditions:

- Input temperature exceeds the expected range for the thermocouple type in use. The expected range for each thermocouple type is listed in the *Discrete and Analog Blocks User's Manual*.
- Overrange: Cold junction sensor reading above +150°C (may be caused by an open wire if XJV sensor is in use).
- Underrange: Cold junction sensor reading below -50°C (may be caused by an open wire if XJI sensor is in use).

Internal Channel Fault: One or more of the block's internal references is faulty. While the fault is present, input data of 0 is reported for each channel using the faulty reference(s).

Configuration

First, the block must be configured with a Hand-held Monitor to:

- Enter its Device Number (serial bus address).
- Enter its Reference Number (required only for IC600 and IC550 series PLCs only).

Note: If a block is configured offline, it must be properly grounded and have a 75 Ohm resistor installed across its Serial 1 and Serial 2 terminals. See the *Discrete and Analog I/O Blocks User's Manual* for instructions. The rest of the features can be configured either using a Hand-held Monitor, or by sending a Write Configuration datagram to the block from the host.

Feature	Circuit or Block	Factory Setting	Selections
Device Number	Block	null	0 to 31 (a number must be selected)
Reference Address	Block	none	Depends on host CPU type
Baud Rate	Block	153.6 std	153.6 std, 153.6 ext, 76.8, 38.4 Kbd
Channel Active	Circuit	yes	yes, no
Report Faults	Circuit	yes	yes/no
Units	Block	°C	C, F, mV, counts
Thermocouple type	Circuit	Type J	J, K, T, E, B, R, S, N or (L)inear
Compensation method	Circuit	Internal	Internal, Ext. voltage, Ext. current, user-supplied
Comp. value (for user-supplied method)	Circuit	0.00mV	+/-326.67mV
Offset value	Circuit	0.00°	+/-100.0°C or +/-100.0°F
Low Alarm	Circuit	-250°C	-32,767 to +32,767 or 0 to +65,535
High Alarm	Circuit	+1400°C	-32,767 to +32,767 or 0 to +65,535
BSM Present	Block	no	yes, no
BSM Controller	Block	no	yes, no
Configuration Protection	Block	disabled	enabled, disabled