



This Datasheet for the

## [IC660BBA025](#)

Block 24/48Vdc Analog Current Source 6 Outputs

<http://www.qualitrol.com/shop/p-14420-ic660bba025.aspx>

Provides the wiring diagrams and installation guidelines for this GE Series 90-30 module.

For further information, please contact Qualitrol Technical Support at

**1-800-784-9385**

[support@qualitrol.com](mailto:support@qualitrol.com)

# Current-source Analog Output Blocks

June 2002

GFK-0546D

## Description

Current-source Analog Output Blocks have 6 output circuits for devices that accept 4 to 20mA signals. Outputs 5 and 6 can also be used for voltage applications. Two Current-source Analog Output blocks are available:

- **115 VAC Current-source Analog Output Block** (IC66\*BBA105)
- **24/48 VDC Current-source Analog Output Block** (IC66\*BBA025)

These blocks are identical except for the power supply.

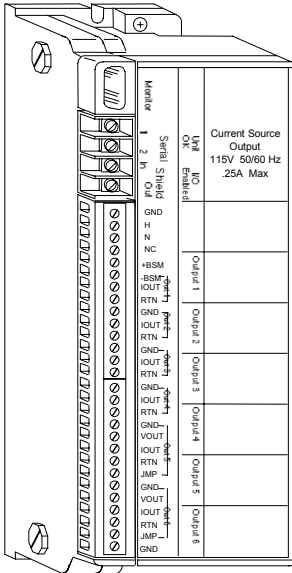

## Features

Block features include:

- Six 4-to-20 mA analog output circuits
- No calibration required for operation
- Software configurable
- Advanced diagnostics
- Dedicated Bus Switching Module control

These blocks provide power to all circuits; no separate power is required for 4-20mA signals. Each output provides power and control of a 4-to-20mA current loop. This power is isolated from the rest of the block. The outputs and BSM circuitry are electrically common. Output accuracy is 0.15% at 25°C. Output resolution is 6µA.

The block has a dedicated digital output that can be used to drive a Bus Switching Module (IC66\*BSM012 only). The outputs and BSM circuitry are electrically common.

Configurable features of these blocks include:

- Output Hold Last State or default
- Circuit scaling to engineering units values
- Output feedback checking and feedback time
- CPU Redundancy

Fault reporting can be enabled or disabled circuit-by-circuit. These blocks automatically perform the following diagnostic checks:

- Output Overage and Underrange
- Output Feedback

## Specifications

### Catalog Numbers

115 VAC/125 VDC Current Source Analog Output Block	IC66*BBA105
Terminal Assembly	IC66*TBA105
Electronics Assembly	IC66*EBA105
24/48 VDC Current Source Analog Output Block	IC66*BBA025
Terminal Assembly	IC66*TBA025
Electronics Assembly	IC66*EBA025

### Block Specifications

Size (height x width x depth)	8.83" (22.44cm) x 3.34" (8.48cm) x 3.91" (9.93cm)		
Weight	4 lbs. (1.8 kg)		
LEDs (I/O Block)	Unit OK, I/O Enabled		
Block to Block Isolation	1500V for one minute		
Heat Dissipation	12 Watts maximum		
Block Power (nominal);	115VAC	125VDC	24/48VDC
Power supply voltage	98-132 VAC	105-145 VDC	18-56
Maximum current	250mA	140mA	600mA
Frequency/ripple	47-63 Hz	10% max. ripple	10% max. ripple
PS dropout time	1 cycle	10 ms min.	10ms min.

### Output Specifications

Output accuracy at 25° C	0.15% of full scale reading		
Output resolution	6µA		
Output update frequency	25ms		
Range	< 4mA to 20mA		
Overrange capacity	0mA to 24mA		
Output diagnostics	Underrange, Overage, Feedback error		
Output load	0 Ohms to 850 Ohms (current application) 0 to 10mA: 0 to 5-volt application 0 to 10mA: 0 to 20-volt (maximum) voltage application		
Thermal drift (from 25°C)	35 PPM per degree C typical		

### Environmental Specifications

Operating temperature	0° C to +60° C (+32° to +140° F)		
Storage temperature	-40° to +100° C (-40° to +212° F)		
Humidity	5% to 95% (non-condensing)		
Vibration	5-10 Hz 0.2" (5.08mm) displacement, 10-200 Hz at 1G		

Refer to GFK-0867B for product standards and general specifications.

\*In the presence of severe RF interference (IEC 801-3, 10 V/m), accuracy may be degraded to +/-0.25% of full scale reading.

# Current-source Analog Output Blocks

June 2002

GFK-0546D

## Compatibility

These blocks are compatible with all Bus Controllers. Handheld Monitor model IC66\*HHM501G (version 4.0) or later is required for configuration.

For an IC697 series PLC, the CPU must be release 2 or later. The bus controller and programming software must be release 3 or later.

For an IC600 series PLC, the CPU must be rev. 105 or later. For an IC600 series "Plus" PLC, rev. 110 or later is required. The bus controller must be IC66\*CBB902 or IC66\*CBB903. The programming software must be rel. 4.02 or later.

For an IC550 series PLC, the CPU must be rev. 3.0 or later. The programming software must be rel. 2.01 or later.

If a Bus Switching Module will be attached directly to the block, it must be the 24/48 VDC version (IC66\*BSM021).

## Using this Datasheet

This datasheet summarizes information about block installation, configuration, and diagnostics.

Your primary reference should be the *Discrete and Analog Blocks User's Manual*. It includes detailed instructions for block installation and configuration.

For additional information about systems and communications, including bus specifications, refer to the *I/O System and Communications Manual*.

## Installation Instructions

Carefully inspect all shipping containers for damage. If any equipment is damaged, notify the delivery service immediately. Save the damaged shipping container for inspection by the delivery service. After unpacking the equipment, record all serial numbers. Save the shipping containers and packing material in case it is necessary to transport or ship any part of the system.

## Block Mounting

Genius I/O blocks are considered "open equipment" and therefore must be installed within a protective enclosure. They should be located in an area that is clean and free of airborne contaminants. There should be adequate cooling airflow.

The block can be mounted right side up, or upside down. Leave at least 2 inches of space between blocks. Mount the block by drilling two screw or bolt holes for 8-32 hardware. Position the block so that the notches in the upper and lower flanges line up with the mounting holes. Mount the block using 8-32 screws. Use star washers to provide ground integrity.

## Grounding

The block's mounting screws must not be used as the only means of grounding the block. Connect the green ground screw on the block to a reliable ground system using a short wire lead, minimum size AWG #12 (avg 3.3mm<sup>2</sup> in cross-section).

### Warning

**If mounting screws do not make good ground connection and the ground screw is not connected to a reliable ground, the block is not grounded. Electrical shock hazard exists. Death or personal injury may result.**

## Block Wiring

Do not overtorque the terminal screws. Recommended torque for all terminals is 6 in/lb (.678 N/M).

## Serial Bus Wiring

Terminals 1 to 4 are for the serial bus. These terminals accept one AWG #12 wire (avg 3.3mm<sup>2</sup> cross-section) or two AWG #14 wires (each avg 2.1mm<sup>2</sup> in cross-section). The minimum recommended wire size is AWG #22 (avg .36mm<sup>2</sup> in cross-section).

Terminals 1 - 4 can also accommodate spade or ring terminals up to 0.27 inch (6.85mm) wide with a minimum opening for a #6 screw, and up to 0.20 inch (5.1mm) depth from the screw center to the back barrier. Be sure unshielded wire ends are not longer than 2 inches (5 cm).

Using one of the cable types recommended in the *System and Communications User's Manual*, connect the serial bus to terminals 1- 4. (If the block will control a Bus Switching Module, see below instead.)

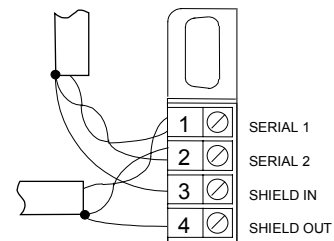

If the block is at either end of the bus, connect a terminating resistor of the appropriate type (see the *System and Communications User's Manual* for details) across its Serial 1 and Serial 2 terminals.

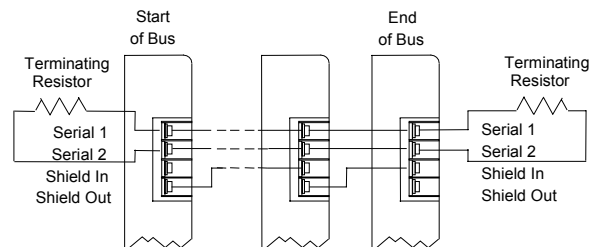

## Connecting a Bus Switching Module

If a Bus Switching Module will be connected *directly* to the block, attach it to the serial bus terminals as shown on the next page. Connect the serial bus cables to the BSM as instructed in the *Bus Switching Module datasheet*. Wire either of the BSM pigtail wires to terminal 9 and the other to terminal 10.

# Current-source Analog Output Blocks

June 2002

GFK-0546D

## Field Wiring

Terminals 5 to 32 are for field devices. They take a single wire up to AWG #14 (avg 2.1mm<sup>2</sup> in cross-section). Minimum recommended size is AWG #20 (avg .54mm<sup>2</sup> in cross-section).

The ground (GND) terminal (5) is for block safety. It is connected to the block chassis, and to terminals 13, 16, 19, 22, 27, and 32 which are marked GND. Each channel has one ground terminal for shield termination, if desired.

## Power Source Wiring

Connect an appropriate power source to terminals 6 and 7. For AC block power, connect the source to the H terminal and neutral to the N terminal. For DC block power, connect the source to the DC+ terminal and the return to the DC- terminal.

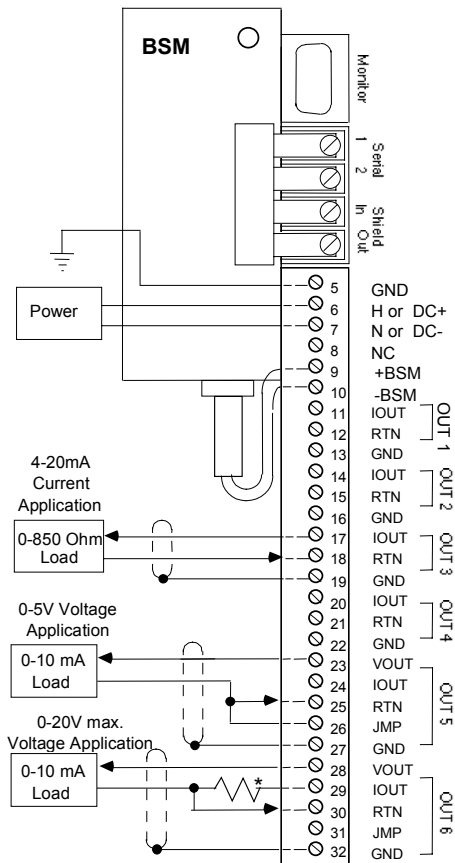

\* User-Specified Resistor: 1K Ohm Maximum

## Wiring for I/O Devices

**Wiring for Current Outputs:** If the load requires current in the 4 to 20mA range, connect it between the IOUT and RTN terminals (for circuits 1 through 6).

**Wiring for Voltage Outputs:** If the load requires 0 to 5 volts power, connect the load across the VOUT and RTN terminals (circuits 5 and 6 only). Attach a jumper across the RTN and JMP terminals.

If the load requires a different voltage range, connect it across the VOUT and RTN terminals. Do not jumper the RTN and JMP terminals. Instead, install an appropriate resistor across the IOUT and RTN terminals. For example, the maximum voltage obtainable if a 500 ohm resistor is used is:

$$V_{MAX} = 20mA * 500 Ohms = 10V$$

## Removing an Electronics Assembly

The block's Electronics Assembly can be replaced with a compatible model without removing field wiring or reconfiguring the block.

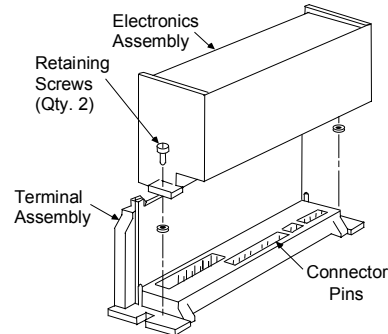

1. Unscrew the retaining screws at the top and bottom of the block.
2. Using a Block Puller (IC660BLM507), engage the tabs in the first vent slots. Move the tool to the center of the block and squeeze the handle.
3. Pull the Electronics Assembly upward.

### Warning

**If power is applied to the field terminals, power is also exposed on the connector pins at the base of the Terminal Assembly, and electrical shock hazard exists. Do not touch the connector pins! Death or injury may result.**

## Inserting an Electronics Assembly

1. Align the Electronics Assembly in the guides and push down firmly.

### Caution

**Do not exert excessive force; it may damage the block.**

2. If unusual resistance is met, remove the Electronics Assembly. If power is applied to the block, DO NOT TOUCH THE CONNECTOR PINS! Inspect the Terminal Assembly, connector receptacle, and connector edge board (on the Electronics Assembly). Be sure the keying matches. Remove any obstacles and reinsert the Electronics Assembly. Pay close attention to the alignment of the guide pins.
3. Secure the Electronics Assembly with the screws on the top and bottom of the Terminal Assembly.

## LEDs

The block's Unit OK and I/O Enabled LEDs show its operating status.

Unit OK	I/O Enabled	Meaning
ON	ON	Block functioning, CPU communicating
ON	OFF	Block functioning No CPU communications for 3 bus scans
ON	Blinking	Block functioning, Circuit forced
Blinking	ON	Circuit fault, CPU communicating
Blinking	OFF	Circuit fault No CPU communications for 3 bus scans
Alternate Blinking		Circuit fault, Circuit forced
Synchronous Blinking		No CPU communications - block number conflict
OFF	Blinking	Electronics/Terminal Assembly mismatch
OFF	OFF	No block power, or block faulty

# Current-source Analog Output Blocks

June 2002

GFK-0546D

## Block Operation

The block has six independent output circuits which are electrically common to each other and the Bus Switching Module outputs, but isolated from all other circuits on the block. Power for the outputs' current loops is provided by the block.

The output channels use a dual 12-bit digital to analog converter, and can independently control currents from 0mA to 24mA.

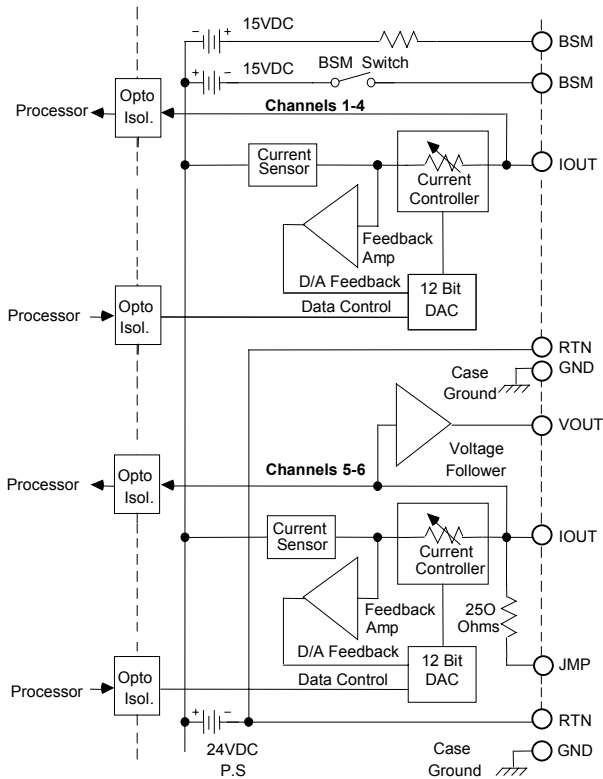

16-bit output data sent to the block is displayed by a Hand-held Monitor as an integer. The block's configured scaling determines the corresponding output signal value.

For example:

An **Output value** of 3581 engineering units with a **Scaling** of 200:1 would produce an **output current** of 17.905mA

## Diagnostics

The block's advanced diagnostics provide the messages listed below. Fault messages can be cleared from the Handheld Monitor or the CPU.

**Output Underrange and Overrange Diagnostics:** The block sends an UNDERRANGE message if conversion of the engineering units output it receives from the CPU results in a commanded output less than 0mA. It sends an OVERRANGE message if conversion of the engineering units output it receives from the CPU results in an output signal level that exceeds 24mA. The block clamps the output to 0mA or 24mA to protect external hardware.

**Output Feedback Error:** This diagnostic is used to detect wiring errors or other hardware faults on output circuits. After waiting for a configurable period of time, the block checks the current level of the output. If it is less than approximately 1.5mA, the block reports a Feedback Error. The block continues sending new values from the CPU to the output. Feedback fault reporting should be disabled if a channel is configured for a voltage application. Nuisance diagnostics may be reported if the Output Feedback Time selected for the circuit is too brief. If this happens, increase the feedback time or disable output feedback testing.

## Configuration

First, the block must be configured with a Hand-held Monitor to:

- Enter its Device Number (serial bus address).
- Enter its Reference Number (required only for IC600 and IC550 series PLCs only).

**Note:** If a block is configured offline, it must be properly grounded and have a 75 Ohm resistor installed across its Serial 1 and Serial 2 terminals. See the *Discrete and Analog I/O Blocks User's Manual* for instructions. The rest of the features can be configured either using a Hand-held Monitor, or by sending a Write Configuration datagram to the block from the host.

Feature	Circuit /Block	Factory Setting	Selections
Device Number	Block	null	0 to 31 (must be selected)
Reference Address	Block	none	Depends on host CPU type
Baud Rate, Kbd	Block	153.6 std	153.6 std, 153.6 ext, 76.8, 38.4
Report Faults	Circuit	yes	yes/no
Channel active	Circuit	active	active/inactive
Output Scaling	Circuit	1µA per eu	+32767 eng units 0 to +24000µA
Output Feedback Enabled	Circuit	yes	yes/no
Output Feedback Time	Circuit	0ms	0 to 255ms
Hold Last State	Circuit	no	yes/no
Output Default	Circuit	4000	+132767 eng. units
BSM Present	Block	no	yes/no
BSM Controller	Block	no	yes/no
Outputs Default Time	Block	2.5 sec	2.5/10 seconds
CPU Redundancy	Block	none	none/standby
Configuration Protection	Block	disabled	enabled, disabled