

115VAC/125VDC 8-Circuit Isolated I/O Blocks

June 2002

GFK-0040E

Description

115 VAC/125 VDC Isolated Genius I/O blocks have four isolated groups of two I/O circuits, each rated to operate at a nominal 115 volts AC or 125 volts DC.

- **115VAC/125VDC 8 Circuit Isolated I/O Blocks** (IC66*BBS102 and BBS100). These blocks report a Failed Switch diagnostic if any output's commanded state is not the same as the actual state of the block's own internal switch.
- **115 VAC/125VDC Isolated I/O Blocks without Failed Switch Diagnostic** (IC66*BBS103 and BBS101). For applications where field wiring such as manual switches will be wired in parallel with block outputs. These blocks ignore differences between an output's commanded state and the actual state of the block's internal switch.

Isolation is rated to withstand 250 VAC/VDC continuous between any group and ground and between any two groups. Transient rating is 2000V peak for 10 sec.

Control power for the block is tapped off the input/output device voltages wired to the terminals. The block has terminals for a separate power source for the internal electronics. The block power supply can be independently either AC or DC. The block need not be powered in the same manner as the circuits.

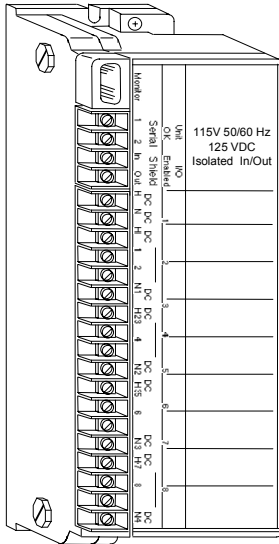

Features

Block features include:

- AC or DC circuit voltage
- Output Pulse Test capability
- Selectable Input Filter Time from 10ms to 100ms
- Output powerup defaults
- Output Hold Last State or default
- CPU Redundancy type
- Bus Switching Module control

Electronic fusing is built into each circuit used as an output. The circuit is shut down 5 μ S after a short occurs. It can be easily restarted from a Hand-held Monitor or from the CPU. The blocks perform these additional diagnostic checks:

- Overtemperature Open Wire for tristate inputs.
- Detection of loss of I/O power on pairs of circuits
- Overload Detection and Shutdown
- No-Load Detection

Specifications

Catalog Numbers	
115VAC/125VDC Isolated I/O Block:	IC66*BBS102, replaces IC66*BBS100
Terminal Assembly	IC66*TSS100
Electronics Assembly	IC66*EBS100
115VAC/125VDC Isolated I/O Block, No Failed Switch:	IC66*BBS103, replaces IC66*BBS101
Terminal Assembly	IC66*TSS100
Electronics Assembly	IC66*EBS101
Block Specifications	
Size (height x width x depth)	8.83" (22.44cm) x 3.34" (8.48cm) x 3.91" (9.93cm)
Weight	4 lbs. (1.8 kg)
LEDs (I/O Block)	Unit OK, I/O Enabled
LEDs (each circuit)	On logic side of switch
Block to block Isolation	1500V
Heat Dissipation	16.8W max. with 8 inputs on, 45.6W max. with 8 outputs at 2 Amps
Required control power	8 Watts maximum (block only)
Operating voltage (one source)	AC: 93-132VAC, DC: 105-132VDC
Frequency	AC: 47-63 Hz, DC: 10% maximum ripple
Power supply dropout time	AC: 1 cycle, DC: 10ms
Input Specifications	
Input processing time (typical)	AC: 2ms + filter, DC: 0.8ms + filter
Selectable input filter times	10 to 100ms in 10ms increments
Input diagnostics	Open Wire, Overtemperature, Loss of I/O Power, Failed Switch
Non-tristate input, OFF state	
min. voltage across input device (IN to H)	AC: 60V RMS, DC: 70 VDC
max. leakage through input device	AC: 1 mA, DC: 2mA
Non-tristate input, ON state	
max. voltage across input device (IN to H)	AC: 20V RMS, DC: 35VDC
max. switch current threshold	AC: 6mA RMS, DC: 5mA
Tristate input, voltage across input device (IN to H)	
OFF state acceptable voltage	AC: 16V RMS-40V RMS, DC: 16 VDC-35 VDC
ON state maximum voltage	AC: 4V RMS, DC: 3.5 VDC
Input load network, Resistor to N:	13K Ohms
Input load network, Capacitor to H:	BBS100 and BBS101: 0.22 μ f BBS102 and BBS103: 0.1 μ f
Output Specifications	
Ckt. output current (steady state)	AC: 2 A RMS, DC: 2A resistive (1A inductive*)
Max. inrush current	Up to 2 cycles: AC: 25A peak, DC: 25A peak (10ms max), 2-6 cycles, AC: 14 Amps peak
Output Leakage (maximum) Current at 0 volt output:	BBS102 and 103, AC: 7mA, DC: 2mA BBS100 and 101, AC: 13mA, DC: 2mA
Output Leakage (maximum) Voltage at open output:	BBS102 and 103, AC: 65V, DC: 40V BBS100 and 101, AC: 95V, DC: 40V
Output switch	(OFF to ON/ON to OFF): Zero crossing
Maximum switching frequency	once per second
Turn-on delay (maximum)	AC: 0.5 Hz + 1ms, DC: 1ms
Voltage drop (at 2A)	2.5 volts
Voltage drop (at 30A inrush)	10 volts
Minimum load (No Load disabled), Resistive:	BBS102 and BBS103, AC: 25mA, DC: 10mA BBS100 and BBS101, AC: 30mA, DC: 10mA
Minimum load (No Load disabled), Inductive:	BBS102 and BBS103, AC: 40mA, DC: 10mA BBS100 and BBS101, AC: 100mA, DC: 10mA
No Load enabled threshold	50mA
Maximum block output current	15 Amps at 35° C, 7.5 Amps at 60° C
Fusing	Internal electronic short circuit trip, 100ms (AC), 10ms (DC) long time trip
Output diagnostics	Short Ckt, Overload, No Load, Overtemp., Loss of I/O Power. BBS100/102: Failed Switch
* DC inductive load rating is 2A with external flyback diode or other coil suppression.	
Environmental Specifications	
Operating Temperature	-0° to +60°C (32° to +140°F)
Storage Temperature	-40 °C (-40° to +212°F)
Humidity	5% to 95% (non-condensing)
Vibration	5-10Hz 0.2" (5.08mm) displacement, 10-200Hz at 1G

Refer to GFK-0867 for product standards and general specifications.

115VAC/125VDC 8-Circuit Isolated I/O Blocks

June 2002

GFK-0040E

Using this Datasheet

This datasheet summarizes information about block installation, configuration, and diagnostics.

Your primary reference should be the *Discrete and Analog Blocks User's Manual*. It includes detailed instructions for block installation and configuration.

For additional information about systems and communications, including bus specifications, refer to the *I/O System and Communications Manual*.

Compatibility

Hand-held Monitor: These blocks are fully compatible with a Hand-held Monitor identified by catalog number IC66*HHM501. They may also be used with HHM500. HHM501 is required to change baud rate configuration, or to configure the block for redundancy.

I/O Blocks: These blocks are backward-compatible with previous block versions (IC66*CBS100, IC66*BBS100, and IC66*BBS101). They may be used as replacements for earlier versions. However, their Terminal Assemblies are not backward-compatible, as explained below.

Electronics Assembly: Electronics Assembly IC66*EBS100H may be used to replace any Electronics Assembly IC66*ELS100 or IC66*EBS100. Electronics Assembly IC66*EBS101C may be used to replace any version IC66*ELS100, EBS100, or EBS101. These Electronics Assemblies draw lower leakage current (7mA) than earlier versions (which drew 13mA).

Terminal Assembly: The Terminal Assembly for these blocks (IC66*TSS100E) is *not compatible with some earlier versions of their Electronics Assemblies* (IC66*EBS100A to G, or IC66*EBS101A or B). If Terminal Assembly IC66*TSS100E will be used to replace an earlier version of the Terminal Assembly, it will also be necessary to upgrade the Electronics Assembly. This can be done by replacing the entire Electronics Assembly with version IC66*EBS100H or IC66*EBS101C, or later. It can also be done by upgrading the Electronics Assembly firmware.

Installation Instructions

Carefully inspect all shipping containers for damage. If any equipment is damaged, notify the delivery service immediately. Save the damaged shipping container for inspection by the delivery service. After unpacking the equipment, record all serial numbers. Save the shipping containers and packing material in case it is necessary to transport or ship any part of the system.

Block Mounting

Genius I/O blocks are considered "open equipment" and therefore must be installed within a protective enclosure. They should be located in an area that is clean and free of airborne contaminants. There should be adequate cooling airflow.

The block can be mounted right side up, or upside down. Leave at least 2 inches of space between blocks. Mount the block by drilling two screw or bolt holes for 8-32 hardware. Position the block so that the notches in the upper and lower flanges line up with the mounting holes. Mount the block using 8-32 screws. Use star washers to provide ground integrity.

Grounding

The block's mounting screws must not be used as the only means of grounding the block. Connect the green ground screw on the block to a reliable ground system using a short wire lead, minimum size AWG #12 (avg 3.3mm² in cross-section).

Warning

If mounting screws do not make good ground connection and the ground screw is not connected to a reliable ground, the block is not grounded. Electrical shock hazard exists. Death or personal injury may result.

Removing an Electronics Assembly

The block's Electronics Assembly can be replaced with a compatible model without removing field wiring or reconfiguring the block.

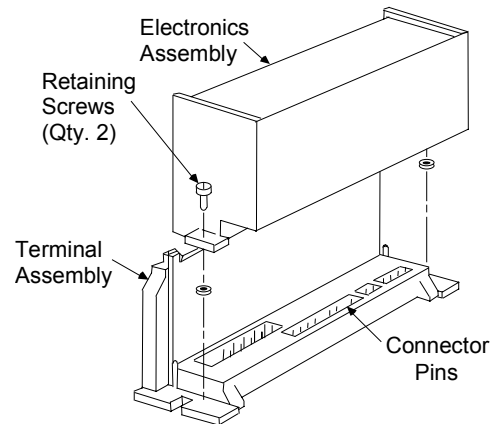

1. Unscrew the retaining screws at the top and bottom of the block.
2. Using a Block Puller (IC660BLM507), engage the tabs in the first vent slots. Move the tool to the center of the block and squeeze the handle.
3. Pull the Electronics Assembly upward.

Warning

If power is applied to the field terminals, power is also exposed on the connector pins at the base of the Terminal Assembly, and electrical shock hazard exists. Do not touch the connector pins! Death or injury may result.

Inserting an Electronics Assembly

1. Align the Electronics Assembly in the guides and push down firmly.

Caution

Do not exert excessive force; it may damage the block.

2. If unusual resistance is met, remove the Electronics Assembly. If power is applied to the block, **DO NOT TOUCH THE CONNECTOR PINS!** Inspect the Terminal Assembly, connector receptacle, and connector edge board (on the Electronics Assembly). Be sure the keying matches. Remove any obstacles and reinsert the Electronics Assembly. Pay close attention to the alignment of the guide pins.
3. Secure the Electronics Assembly with the screws on the top and bottom of the Terminal Assembly.

Block Wiring

All terminals accept one AWG #12 wire (avg 3.3mm² cross-section) or two AWG #14 wires (each avg 2.1mm² in cross-section). The minimum recommended wire size is AWG #22 (avg .36mm² in cross-section).

Terminals 1 - 4 can also accommodate spade or ring terminals up to 0.27 inch (6.85mm) wide with a minimum opening for a #6 screw, and up to 0.20 inch (5.1mm) depth from the screw center to the back barrier. Be sure unshielded wire ends are not longer than 2 inches (5 cm).

Do not overtorque the terminal screws. Recommended torque for all terminals is 6 in/lb (.678 N/M).

115VAC/125VDC 8-Circuit Isolated I/O Blocks

June 2002

GFK-0040E

Serial Bus Wiring

Using one of the cable types recommended in the *System and Communications User's Manual*, connect the serial bus to terminals 1- 4. (If a Bus Switching Module will be connected *directly* to the block, see below instead).

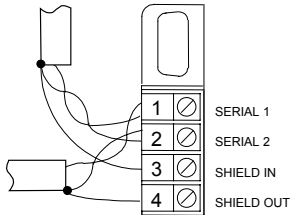

If the block is at either end of the bus, connect a terminating resistor of the appropriate type (see the *System and Communications User's Manual* for details) across its Serial 1 and Serial 2 terminals.

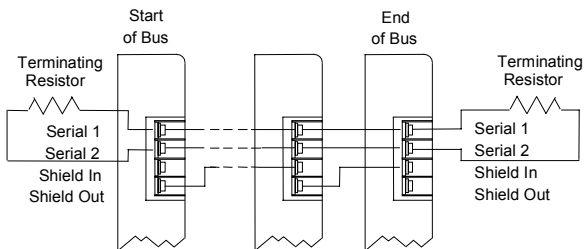

Wiring for a Bus Switching Module

If the block will be a BSM Controller, install the Bus Switching Module at the block's serial bus terminals. Attach the bus cables to the BSM terminals, as described in the Bus Switching Module datasheet. Wire the BSM like a load to circuit 1 by connecting either BSM pigtail wire to terminal 8, and the other to neutral or DC- (such as terminal 10).

Power Connections

Up to five separate power sources can be connected to the Terminal Assembly. Circuit power and block power do not have to be the same type. Block power may be DC while circuit power is AC, or the reverse. Isolation is rated to withstand 250 volts AC or DC continuous between any group and ground, or between any two groups.

Block Power

For block power, connect a 115 volt AC or 125 VDC source to the top H terminal (5). Connect neutral to the N terminal (6). All H terminals are internally bussed, as are all N terminals.

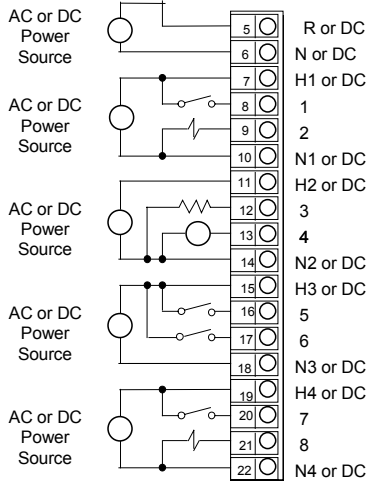

Circuit Power

Each circuit pair can have its own power supply. All circuits must use either AC or DC power. If circuit power is AC, both circuits of a pair must be wired to the same AC phase. However, different pairs of circuits can be wired to different C phases.

Caution

If separate AC power is used for any group of circuits on a block, all power connections within the group must be wired to that same 120 VAC source.

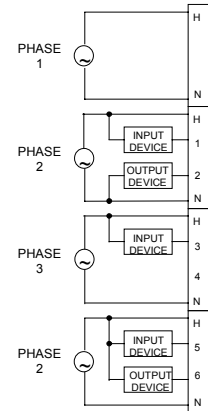

Wiring for I/O Devices

For each input device, connect one terminal to the Hot side of AC power or positive side of 125 VDC. Connect the other to the I/O block at terminal 8, 9, 12, 13, 16, 17, 20, or 21.

For each output, connect one terminal to block terminal 8, 9, 12, 13, 16, 17, 20, or 21. Connect the other to the neutral side of AC power or the negative side of 125 VDC. The block must have both sides of power connected to it.

Only one wire need be run to the field device. Depending on the layout and current loads, hot connections can be bussed together and made by one wire to the block or power source. Neutral connections can also be bussed together and made by one wire.

Wiring for Tristate Inputs

For input circuit configured as a tristate input, install a 5.1K ohm, 1/2 Watt or larger non-inductive resistor across the dry contacts of the input device. This added resistance is required to use the Open Wire diagnostic.

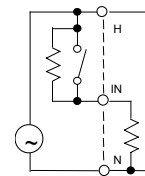

Interfacing Small Loads to an Isolated Block

If any output will drive an inductive load drawing less than 50 mA, it may be necessary to add resistance at the load. See the *Genius Discrete and Analog I/O Blocks User's Manual* for instructions.

External Suppression

If a contact is wired between the block and a load, install suppression across the load. Resistor capacitor suppressors are preferred for low current, high inductance loads. For a high-power load, instead use a voltage-clamping device such as a MOV. RC suppressors are also recommended to reduce electro-magnetic interference.

Power supply-side switches may require line to line suppression if power is to be switched with devices energized.

See the *Discrete and Analog I/O Blocks User's Manual* for more information about using suppression.

115VAC/125VDC 8-Circuit Isolated I/O Blocks

June 2002

GFK-0040E

Block Operation

An Isolated block has four isolated groups of two I/O circuits, each rated to operate at a nominal 115VAC or 125VDC.

The block can be configured as an inputs-only, outputs-only, or combination block.

If the block is configured as a combination block, circuits can be any mix of inputs and/or outputs. The actual state of each output will be returned to the CPU in the corresponding input reference location. The CPU can monitor the feedback state to verify (after an appropriate delay) that the output switching device has operated properly and that the load has the proper voltage and current applied.

If the block is configured as an inputs-only block, all circuits must be regular inputs or tristate inputs. If the block is configured as an outputs-only block, all circuits must be outputs; no feedback analysis will be performed.

Each circuit has its own LED. If the circuit is used as an input, the LED indicates the presence of threshold voltage at the input terminal. If the circuit is used as an output, the LED indicates the state commanded by the CPU.

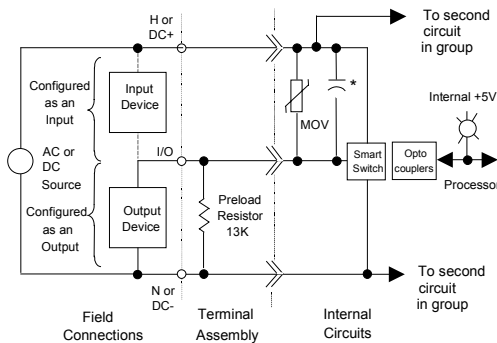

* .2µF for Block IC66*BBS100 and 102
.1µF for Block IC66*BBS101 and 103

LEDs

The block's Unit OK and I/O Enabled LEDs show its operating status:

Unit OK	I/O Enabled	Meaning
ON	ON	Block functioning, CPU communicating
ON	OFF	Block functioning, No CPU communications for 3 bus scans
ON	Blinking	Block functioning, Circuit forced
Blinking	ON	Circuit fault, CPU communicating
Blinking	OFF	Circuit fault, No CPU communications for 3 bus scans
Alternate Blinking		Circuit fault, Circuit forced
Synchronous Blinking		No CPU communications - block number conflict
OFF	Don't Care	No block power, or block faulty

For each input circuit, the circuit LED indicates the presence of threshold voltage at the input terminal. Output circuit LEDs show the state commanded by the CPU.

Diagnostics

The block's advanced diagnostics provide the messages listed below. Fault messages can be cleared from the Hand-held Monitor or the CPU.

Loss of I/O Power: One pair of switches is disconnected from field power. Result: if either of the disconnected circuits is an input, the block sets it to 0. Any disconnected output is turned off. The Loss of I/O Power diagnostic message is automatically sent to the HHM, but it is not automatically sent to the CPU unless the block is Pulse Tested. The Unit OK light will not blink if a Loss of I/O Power fault occurs.

Open Wire: Voltage, but no current detected on tristate input.

Overtemperature: The block's internal temperature exceeds 100°C. The block sends an OVERTEMPERATURE message and turns off the circuit.

Short Circuit: The instantaneous current on an output exceeds 30 Amps during the first two line cycles or 20 Amps thereafter. The block turns the output off within microseconds.

Overload: A load exceeds 2.8 Amps (2.0 Amps RMS) continuously for 100ms. The block turns the output off.

No Load: Optional. The load does not continuously draw 50 mA from the output circuit.

Failed Switch: For blocks IC66*BBS100 and BBS102, this diagnostic typically indicates that a circuit's internal feedback state is not the same as the commanded state.

Blocks IC66*BBS101 and BBS103 ignore differences between an output's commanded state and the actual state of the internal switch. They do not modify the output state if a discrepancy exists. Blocks BBS101 and BBS103 should be used in applications where mechanical switches on outputs would cause false Failed Switch diagnostic messages to be generated.

All of these blocks may generate a Failed Switch diagnostic if internal failure of a switch is detected.

Configuration

First, the block must be configured with a Hand-held Monitor to:

- Enter its Device Number (serial bus address).
- Enter its Reference Number (required only for IC600 and IC550 series PLCs only).

Note: If a block is configured offline, it must be properly grounded and have a 75 Ohm resistor installed across its Serial 1 and Serial 2 terminals. See the *Discrete and Analog I/O Blocks User's Manual* for instructions. The rest of the features can be configured either using a Hand-held Monitor, or by sending a Write Configuration datagram to the block from the host.

Feature	Circuit or Block	Factory Setting	Selections
Baud Rate	B	153.6 std	153.6 std, 153.6 ext, 76.8, 38.4
Block I/O Type	B	input	input, output, combination
AC/DC Circuit Voltage	B	AC	AC or DC
Pulse Test	B	enabled	enabled, disabled
Input Filter Time	B	20ms	10-100ms
Circuit I/O Type	C	input	input, output, tristate input
Report Faults	C	yes	yes, no
Hold Last State	C	no	yes, no
Output Default	C	off	on, off
Report No Load	C	yes	yes, no
Overload Shutdown	C	yes	yes, no
BSM Present	B	no	yes, no
BSM Controller	B	no	yes, no
Output Timeout	B	2.5 sec	2.5, 10 seconds
Redundancy Mode	B	none	none, standby, duplex
Duplex Def. State	B	off	on, off
Config. Protect	B	disabled	enabled, disabled