



This Datasheet is for the

[IC693ACC301](#)

Backup Battery for RAM Memory

<http://www.qualitrol.com/shop/p-14537-ic693acc301.aspx>

Provides the wiring diagrams and installation guidelines for this GE Series 90-30 module.

For further information, please contact Qualitrol Technical Support at

1-800-784-9385

support@qualitrol.com

Chapter 6

Memory Backup and Backup Battery

Backup Battery for RAM Memory (All Supplies)

The long-life Lithium battery (IC693ACC301) used to maintain the contents of the CMOS RAM memory in the CPU is accessed by removing the cover plate located at the bottom of the power supply faceplate. This battery is mounted on a plastic clip attached to the inside of this cover.

The battery is wired to a small Berg female connector that connects to either of the two Berg male connectors mounted on the Power Supply printed circuit board. This battery can be replaced with power applied to the PLC.

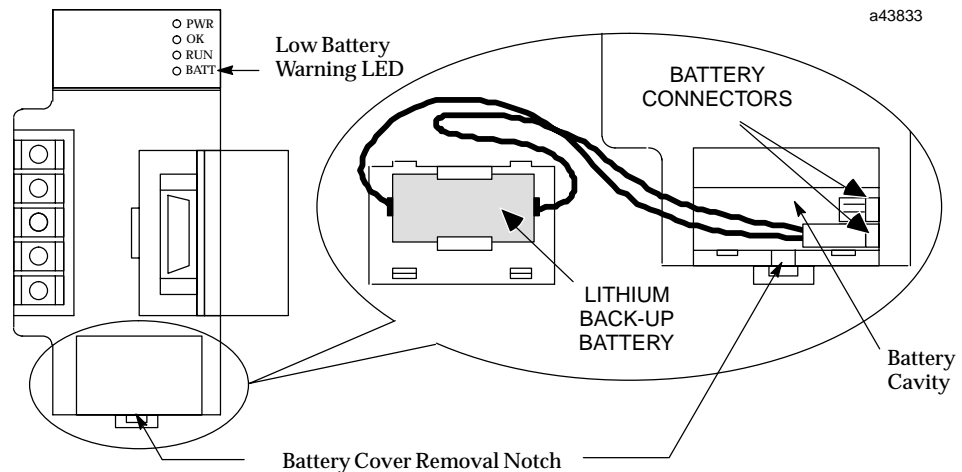

Figure 6-1. Backup Battery for RAM Memory

Caution

If a Low Battery Warning (BATT LED turns ON) occurs, replace the battery located in the power supply *before* removing power from the rack. Otherwise, there is a possibility that data will be corrupted or the application program will be cleared from memory.

Battery Replacement Instructions

Warning

To avoid the chance of losing the contents of RAM memory, you can carefully perform the following steps with PLC power ON. This procedure should only be performed by qualified electrical personnel who are trained in applicable electrical safety rules and procedures. Failure to follow standard electrical safety practice can result in injury or death to personnel, damage to equipment, or both.

- Carefully insert the tip a small pocket-size screwdriver approximately 1/4 inch (6 mm) into the battery cover removal slot, located beneath the battery cover (see previous figure).
- Gently rotate the screwdriver about 45 degrees to loosen the cover.
- Remove cover with fingers. The battery is mounted in a clip on the back of the cover. It has a pair of leads with a connector that is plugged-in to a connector on a circuit board inside the power supply.
- Carefully reach into battery cavity with your fingers (do not use a metal object to do this) and unplug the battery connector.
- Remove the old battery from the clip on the battery cover and set it aside. Be careful not to mix it up with the new battery.
- Carefully reach into battery cavity with your fingers (do not use a metal object to do this) and plug in new battery connector.
- Clip new battery into clip on battery cover.
- Snap battery cover back onto power supply.

Battery Replacement/Memory Protection Factors

Since there are differences in each PLC application, each user will have to determine on an individual basis what strategy to use. There are several factors to consider when planning a battery replacement/memory protection strategy:

- How critical is the application? Will considerable loss be sustained if the PLC goes down? If so, frequent replacement of the battery would be a wise choice. For critical applications, the cost of a battery would be quite low in comparison to the cost of a PLC shut-down.
- How readily can a backup program be loaded? Are there technicians on-site who know how to load a backup program? Is the backup program accessible at all times to those responsible for maintaining the equipment? Is a personal computer or equivalent equipped with GE Fanuc programming software available at all times for use in loading the backup program?
- Do you have a preventive maintenance program? A formal program would help ensure that the battery is replaced on time. Some users replace the backup battery each year during their annual shut-down period.
- How accessible is the PLC? In some applications, the PLC may be mounted in a remote location that is not easily accessed.
- Safety codes. Some users may have safety rules that would not allow replacing the battery with power applied.
- How is the PLC used? Is power left on all the time, or is it shut down every day? See the heading "Factors Affecting Battery Life."
- Some users run without a backup battery by using one of the PROM options. See the section below called "Operating Without a Memory Backup Battery" to determine if this strategy is suitable for your application.

The Importance of Backing up your Program

Experience has shown that regardless of what strategy you use to maintain PLC memory, you should, additionally, always keep an up-to-date backup copy of your application program. The effort required to create and maintain a backup copy is very small compared to the work required to reprogram, or re-key from hardcopy, your entire application if, due to some misfortune, it was lost. Other suggestions to help minimize down time:

- Make sure the backup copy is readily accessible to those who may need to use it.
- Train more than one person to load the backup program in case that one person is not available when needed. Information on creating a backup can be found in GE Fanuc's software user's manuals. This procedure is also covered in applicable GE Fanuc programming software training courses.
- Ensure that a suitable computer (usually a laptop type) is equipped with GE Fanuc PLC programming software and will be readily available to load the backup program to the PLC.
- Create a written backup procedure. Fortunately, restoring your program from the backup copy is probably not something you will do very often. As a result, however, some of the steps could easily be forgotten.

Factors Affecting Battery Life

Replacing your battery once per year is a good rule of thumb. However, no one can predict precisely how long a backup battery will last because this depends upon what CPU is used, what temperature it is subjected to, and how it is used. Considering the following list of factors that affect battery life will help you decide how frequently to replace the battery in your application:

- A battery that is not in use has an estimated life (called its "shelf life") of 5 years at "room temperature" (25 degrees C, or 77 degrees F).
- A battery that is used continuously (supplying current to memory circuits with PLC power off) has an average estimated life of one year for CPU models 331 and above, and 2 years for CPU models 311, 313 and 323, if used at room temperature.
- As long as a PLC is powered up, its battery is not being used; so how often you power down your PLC has a direct affect on battery life. Some users keep their PLC powered up all of the time while others turn theirs off every night.
- Temperature has a relatively large affect on battery life. Temperatures considerably above room temperature (25 degrees C, or 77 degrees F), or below freezing (0 degrees C, or 32 degrees F) will appreciably shorten battery life.
- The type of CPU has a small affect on battery life. Some CPUs have more memory than others. Also, some CPUs have a clock and some do not. More memory requires more battery current to maintain its contents; and a clock requires battery current to maintain its operation.

Low Battery Warning Methods

There are three basic ways that the PLC warns of a low battery:

- The red "BATT" LED on the Power Supply module lights when the battery is low. The disadvantage of this method is that the PLC is often mounted in an enclosure, so this LED might not be easily seen.
- The PLC Fault Table is updated with a battery low message. Viewing the PLC Fault Table requires that a programmer be connected to the PLC.
- Certain System Reference bits are set to logic 1 when the battery is low. These are %SA011 (LOW_BAT), %SC009 (ANY_FLT), %S010 (SY_FLT), and %SC012 (SY_PRES). The most specific is %SA011 (LOW_BAT). This bit could be used as a contact in your ladder logic program to turn on an output that controls a warning light on an operator panel (as in the example rung below), or to send a warning to an operator interface terminal.

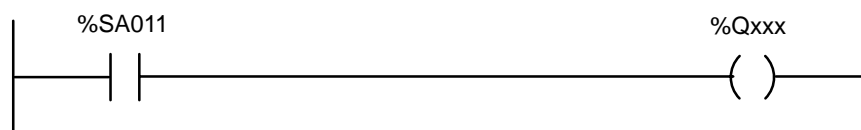

In the rung shown above, the %SA011 contact will close when a low battery is detected by the PLC. This will turn on the %Q output coil, which addresses an output module's output that will turn on a warning light. An alternate method would be to communicate the status of the coil (which, in that case, would probably be a %M coil) to a Human to Machine Interface (HMI) terminal such as a GE Fanuc CIMPLICITY HMI unit. The HMI could be programmed to display a warning message when that

particular bit goes to a logic 1. For more information about System Reference bits and ladder logic programming, see the the *Series 90-30/20/Micro PLC CPU Instruction Set Reference Manual*, GFK-0467.

Operating Without a Memory Backup Battery

Whether it would be to your advantage to use a battery-less scheme depends on your application. There are various advantages and disadvantages to consider in making your decision.

Possible Advantage

The obvious advantage of operating without a memory backup battery is that you are freed from the need to maintain the battery. To be able to run without a battery, you need to have a PROM device – either an EPROM, EEPROM, or Flash PROM – installed in your system. These devices can store program logic, configuration, and register values without the need for a backup battery, and you can configure your CPU to read the contents of PROM into RAM memory each time the PLC is powered up.

Possible Disadvantages

Information is not stored to your PROM device automatically. To store information, you must stop the PLC, then use a programming device to tell the CPU to write the current PLC (RAM) memory contents to the PROM device. This requirement may make battery-less operation undesirable for many users. For example, in many applications, important data is gathered and stored in RAM register memory, data such as the current level of material in a tank that is being filled, or a running count of parts produced, etc. This constantly changing data is not being copied automatically to the PROM device. It only exists in RAM memory. Therefore, if power is lost and there is no RAM memory backup battery, this data will be lost.

However, one way to preserve data in a battery-less system is to send it over a network to a computer that can store the data on its hard drive. Also, static data (data that doesn't change) contained in RAM memory, such as mathematical constants or look-up table type information, can be stored initially in PROM and automatically written back to RAM each time the PLC powers up.

Another consideration is that if you change your program (or configuration), someone will have to remember to write the changed information to the PROM device. If that step is forgotten, then the change only exists in RAM memory, and in a battery-less system, it will be lost the next time power is removed from the PLC.

Configuring a Battery-Less System

Here are the basic steps to configure a system to run battery-less:

- Equip your CPU with a PROM device. On some CPUs a PROM device is purchased as an option; on others, it is a standard feature. The CPU chapter of this manual has a table that identifies the standard PROM configuration for each CPU.
- There are three CPU configuration parameters involved. Configure them as follows: **Pwr Up Mode:** RUN; **Logic/Cfg:** PROM; **Registers:** PROM.
- Store your folder (include Program Logic, Configuration, and Register Data) to the PLC. This places your entire folder into RAM (working) memory.

- Write PLC (RAM) memory to the PROM device. Make sure you write all data (Program Logic, Configuration, and Register Data) to the PROM. Note that the type of PROM device depends on what model CPU you have and how it is equipped.
- If you are using a 340 or higher CPU (such as a CPU350, CPU351, etc.), read the next section for an additional requirement.

When configured this way, the contents of PROM memory will be written into RAM memory each time the PLC powers up.

Operation Without a Memory Backup Battery Using a 340 or Higher CPU

This information is applicable only to CPU model numbers 340 and higher (such as CPU350, CPU351, etc.). In systems that do not use a memory backup battery, a standard 0.1" Berg jumper should be installed across either of the two power supply battery connectors to ensure reliable restarting of the CPU after a power cycle. This jumper should not be installed if a battery is plugged into either the power supply or CPU battery connector.

Determining Battery Age Using Battery Date Code

Battery age can be determined from the date code stamped on the battery.

The battery, manufactured by Panasonic, will have a four-digit date code. It will be something like 5615 or 7Y34. Use the following information to determine the date of manufacture.

- First digit shows the year in a rotating 10-year cycle. For example, 0=1990, 1=1991, 2=1992 ... 9=1999, 0=2000, 1=2001, 2=2002, etc. This seeming duplication should not be a problem because the shelf life of these batteries is 5 years. Batteries in inventory that are older than 4 years old should be discarded according to the manufacturer's instructions (since they have less than one year of life remaining we would not recommend using them in a PLC). This will ensure that outdated batteries are not mistaken for newer batteries.
- Second digit shows the month. 1=January, 2=February, 3=March, 4=April, 5=May, 6=June, 7=July, 8=August, 9=September, O=October, Y=November, Z=December.
- Third digit shows the week of the month.
- Fourth digit shows the day of the week. 1=Monday, 2=Tuesday, 3=Wednesday, 4=Thursday, 5=Friday, 6=Saturday, 7=Sunday.

For example, the code 7612 is interpreted as:

Manufactured on June 3, 1997

RAM Memory Battery Backup Connection Path

CMOS RAM memory is a volatile type of memory, which means that it can lose its contents (ladder program, configuration, etc.) if power is removed. To retain RAM memory contents under no-power conditions, a long-life lithium battery is provided. This battery is normally mounted in the rack's Power Supply module. To avoid accidental disconnection of the memory backup battery, it is beneficial to know the connection path between the battery and the memory circuits:

For embedded CPUs: The battery connection path to RAM memory is through the Power Supply's baseplate connector and across the backplane board to the RAM circuits.

For modular CPUs: The battery connection path to RAM memory is through the Power Supply's baseplate connector, across the backplane board, and through the CPUs baseplate connector to the RAM circuits inside the CPU module.

Obviously, removing the Power Supply module from the PLC breaks the connection between the backup battery and the RAM memory circuits for both embedded and modular CPUs. Also, in a modular CPU system, removing the CPU module would disconnect the backup battery from the memory circuits. ***In addition, to avoid the possible problems associated with losing the contents of RAM memory, we recommend that you maintain an up-to-date backup copy of your program folder.*** Instructions for creating program folder backups can be found in the *Logicmaster 90, Series 90-30 Programming Software User's Manual*, GFK-0466, *Control User's Guide*, GFK-1295, and *VersaPro Programming Software User's Guide*, GFK-1670.

Super Capacitor Memory Backup

Besides the backup battery, the RAM memory circuits in both Embedded and Modular CPUs are further protected by a "super capacitor," which can store enough charge to maintain memory for a short time if the battery is disconnected. The amount of protection time provided by the super capacitor depends on the following:

- The PLC power supply supplies 5 VDC to the memory circuits, including the super capacitor. Therefore, when PLC power is turned off, the super capacitor has an initial 5 VDC charge. If the battery is also disconnected shortly after PLC power is turned off, the super capacitor will begin discharging from the 5 VDC level until its charge reaches 2 VDC, at which time memory contents will be lost. When used this way, the super capacitor can maintain memory contents for a minimum of 1 hour.
- The memory backup battery supplies 3 VDC to the memory circuits, including the super capacitor. Therefore, if PLC power has been turned off for an hour or more and only the battery is powering the memory circuits, the super capacitor has a 3 VDC charge. Then, if the battery is disconnected, the super capacitor will begin discharging from the 3VDC level until its charge reaches 2 VDC, at which time memory contents will be lost. When used this way, the super capacitor can maintain memory contents for a minimum of 20 minutes.

Maintaining RAM Memory During Storage or Shipment of a CPU

Modular CPUs

Modular CPUs have an internal connector for a backup battery so that RAM memory contents can be retained while the CPU is being stored or shipped. This arrangement should not to be used when the CPU module is installed in the baseplate and the backup battery is installed in the power supply. To use a backup battery in the CPU module, it is necessary to remove the front cover of the CPU module. This can be accomplished by following these steps:

- To avoid losing memory contents once the CPU is removed from the PLC, we recommend you install the backup battery into the CPU within 20 minutes. First, make sure PLC power is off, then remove the CPU module.
- Gently squeeze the front cover of the CPU module and pull it forward, away from the module case, while gently pressing in on the 4 front cover tabs sequentially with

a small screwdriver. The front cover tabs latch into holes on each side of the module case (refer to Figure 2-1 for location of front cover holding tabs).

- After removing the front cover, plug the memory backup battery into the two-prong battery connector on the front of the CPU module's printed circuit board.
- While the battery is connected to the CPU, you will have to leave the CPU's front cover off. Also, the battery should be temporarily secured to the module with cable ties or tape to keep it from being accidentally damaged or disconnected.

The Battery Accessory Kit, described below, may also be used on a Modular CPU baseplate if the power supply has to be removed. This would require leaving the CPU module mounted in the baseplate.

Embedded CPUs

Embedded CPU Models 311, 313, and 323 can be stored or shipped with a power supply installed and the power supply battery connected in order to maintain the contents of RAM memory. However, another option (that doesn't require the use of a power supply) is to use the Battery Accessory Kit, described next.

Battery Accessory Kit (IC693ACC315)

The Battery Accessory Kit (IC693ACC315) lets you maintain RAM memory contents without using a power supply. It is useful for maintaining memory contents while a baseplate is being stored or shipped. The Battery Accessory Kit consists of a battery with an attached connector mounted on a circuit board. The circuit board has a connector that plugs into the power supply backplane connector (see the figure below). The Battery Accessory Kit can be used on either Embedded or Modular Series 90-30 CPU baseplates.

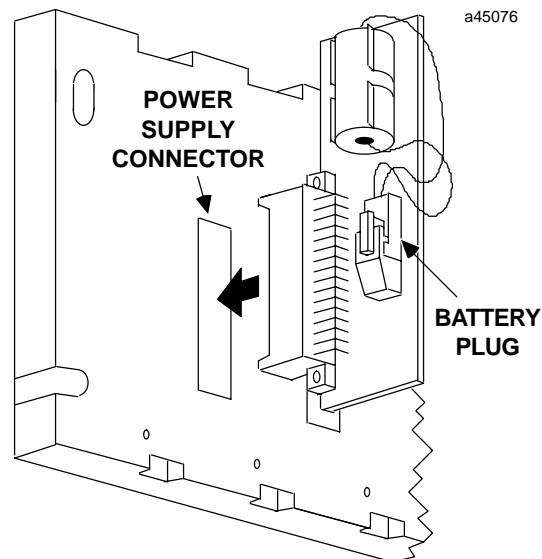

Figure 6-2. Installing the Battery Accessory Kit

Battery Accessory Kit Installation

1. Insert the plug on the end of the battery cable into the 2-pin connector on the Battery Accessory board. The battery plug is normally not plugged into the accessory connector. This prevents accidental discharge of the battery during storage and handling.
2. Align the backplane connector on the Battery Accessory board with the power supply connector on the baseplate backplane. Push the Battery Accessory board toward the baseplate until it is fully seated. See the figure above.
3. If the baseplate is to be shipped with the Battery Accessory board installed, ensure that the board is held in place by packing material or cable ties. The cable ties can be installed in holes provided on both ends of the accessory board and secured to the baseplate.

Caution

To avoid losing CPU data, the Battery Accessory must be installed within 1 hour after turning off PLC power, or 20 minutes after removing the memory backup battery. See the section “Super Capacitor Memory Backup” section for details.

When the Battery Accessory is removed, a power supply module with a good battery must be installed and/or input power applied within 20 minutes to avoid losing CPU data. See the section “Super Capacitor Memory Backup” section for details.

Batteries in Power Supplies on Expansion or Remote Racks

Batteries in power supplies on Expansion or Remote racks, are not in use. Only the battery in a CPU rack supplies backup power to RAM memory. Batteries in non-CPU racks may be removed and used as spares, if they meet the age requirements stated previously in this chapter.