



This Datasheet is for the

[IC693ALG390](#)

Analog Voltage Output - 2 Channel

<http://www.qualitrol.com/shop/p-14574-ic693alg390.aspx>

Provides the wiring diagrams and installation guidelines for this GE Series 90-30 module.

For further information, please contact Qualitrol Technical Support at

1-800-784-9385

support@qualitrol.com

Chapter 11

Analog Output Modules

Analog Voltage Output - 2 Channel IC693ALG390

The *2-Channel Analog Voltage Output* module for the Series 90-30 Programmable Logic Controller provides two output channels, each capable of converting 13 bits of binary (digital) data to an analog output for use as required by your application. The Analog Voltage Output module is capable of providing outputs in the range of -10 to $+10$ volts. Resolution of the converted signal is 12 bits binary plus sign which is effectively 13 bits (1 part in 8192). Both channels are updated on every scan (about 5 milliseconds). User data in the %AQ registers is in a 16-bit 2's complement format. The 13 most significant bits from the %AQ register are converted to sign magnitude by the PLC and sent to the module for use by the D/A converter circuitry. The placement of the 13 bits converted to sign magnitude is shown below. The relationship between the voltage output and the data from the D/A converter is shown in Figure 3-30.

MSB													LSB		
S	D11	D10	D9	D8	D7	D6	D5	D4	D3	D2	D1	D0	X	X	X

S = Sign bit.
X = not applicable to this discussion.

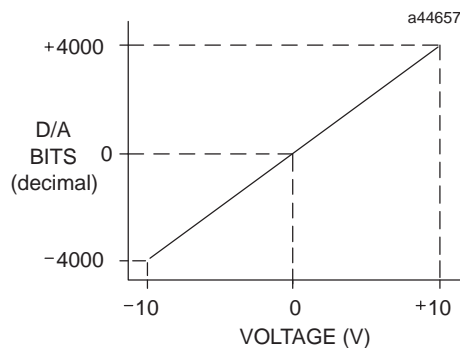

Figure 11-1. D/A Bits vs. Voltage Output

The state of the module, if the CPU goes to the STOP mode or RESET, can be either *Default to 0 volts* or *Hold-Last-State*. Selection of the desired state is made by configuring the DEF0 jumper on the detachable terminal connector on the module. If the jumper is not installed, the outputs will Hold-Last-State on STOP or RESET. Scaling of the output is shown below.

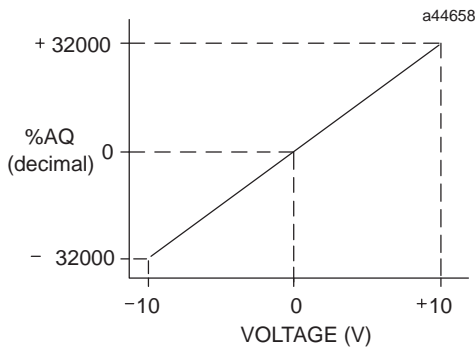

Figure 11-2. Scaling for Voltage Output

The primary power source for the module is the isolated +24 VDC power supplied by the PLC power supply. Two terminals are provided on the module’s terminal connector for user supplied +24 volts. This allows you to provide a standby power supply, so that the outputs can continue to hold their value if the internal supply is lost and Hold Last State is selected. Additionally, you can also supply the module voltage to reduce the load on the PLC isolated +24 VDC power supply. The user supply must be used when the applied voltage is 0.7 volts higher than the isolated +24 VDC supply, which can range from 21.5 volts to 26.5 volts. An LED at the top of the module’s faceplate is ON when the module’s power supply is operating.

To minimize capacitive loading and noise, all field connections should be wired using a good grade of twisted, shielded instrumentation cable. The shields should be connected to GND on the user terminal connector block. The GND connection provides access to the baseplate (frame ground) resulting in superior rejection of noise caused by any shield drain currents.

The module provides electrical isolation of externally generated noise between field wiring and the backplane through the use of optical isolation. This module can be installed in any I/O slot of a 5 or 10-slot baseplate in a Series 90-30 PLC system. Refer to page 3-11 to determine the number of Analog Voltage Output modules that can be installed in a system.

Table 11-1. Specifications for Analog Voltage Output Module, IC693ALG390

Voltage Range	-10 to +10 volts
Calibration	Factory calibrated to 2.5 mV per count
Supply Voltage (nominal)	+24 VDC, from isolated +24 VDC on backplane or user supplied voltage source, and +5 VDC from backplane
External Supply Voltage Range	18 to 30 VDC
External Supply Voltage Ripple	10%
Update Rate	5 msec (both channels) <i>This update rate is approximate since it is determined by I/O scan time, and is application dependent.</i>
Resolution	2.5 mV (1 LSB = 2.5 mV)
Absolute Accuracy †	± 5 mV at 25° C (77° F)
Offset	1 mv maximum, 0 to 60° C (32° to 140° F)
Output Loading (maximum)	5 mA (2K ohms minimum resistance)
Output Load Capacitance	2000 pico farads, maximum
Isolation	1500 volts between field side and logic side
Internal Power Consumption	32 mA from +5 volt supply 120 mA from +24 volt supply (isolated backplane or user supply)

Refer to Appendix B for product standards and general specifications.

† In the presence of severe RF interference (IEC 801-3, 10V/m), accuracy may be degraded to ±50mV.

IC693ALG390 Analog Voltage Output Block Diagram

The following figure is a block diagram of the 2-Channel Analog Voltage Output Module, IC693ALG390.

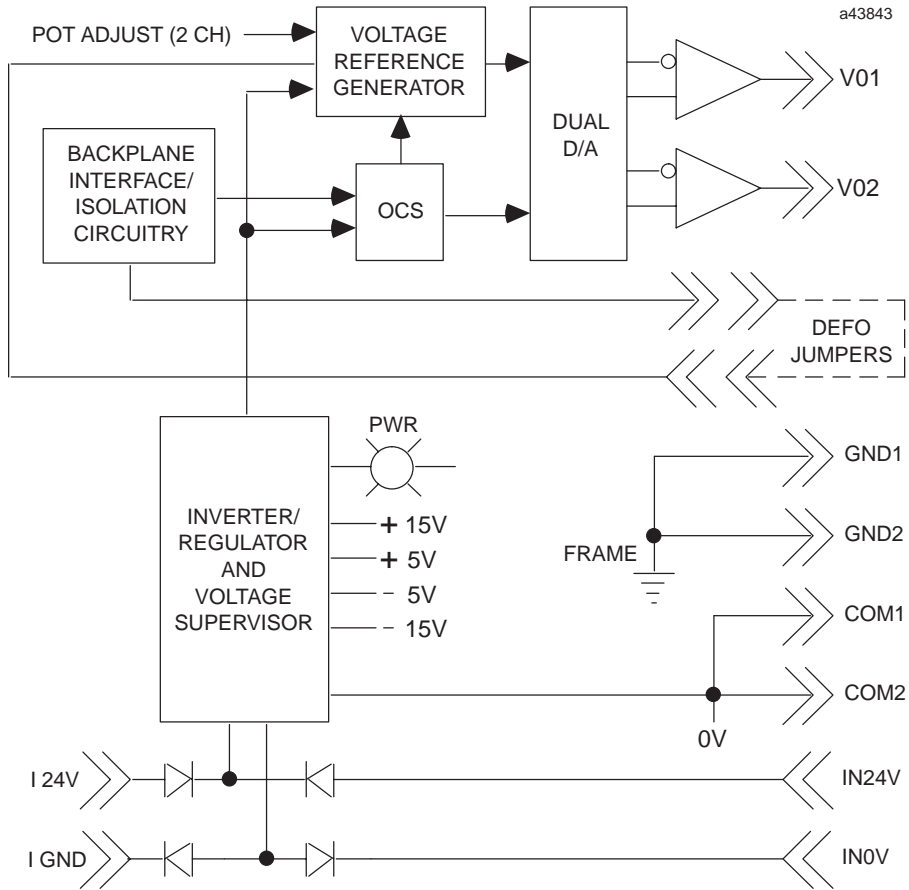

Figure 11-3. Analog Voltage Output Module Block Diagram - IC693ALG390

IC693ALG390 Analog Output Module Field Wiring Diagram

The following figure provides information for connecting field wiring to the Analog Voltage Output module.

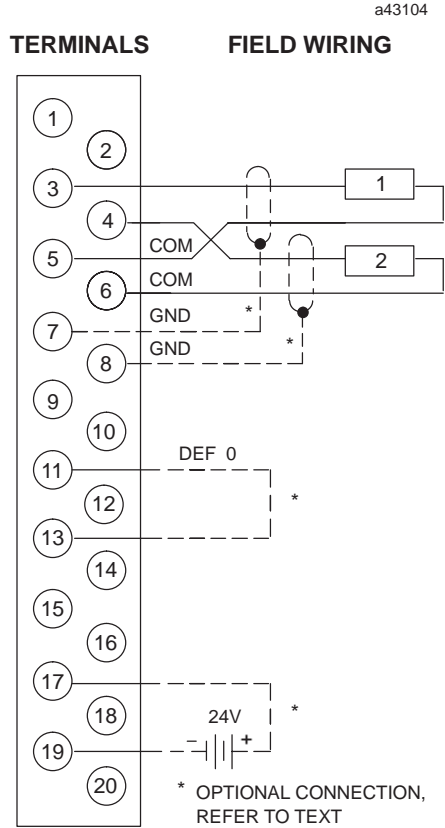

Figure 11-4. Field Wiring for Analog Voltage Output Module - IC693ALG390

Note

Please refer to Chapter 2 for wiring and shield ground connection details.