



This Datasheet is for the

IC693CBL300

I/O Bus Expansion Cables

<http://www.qualitrol.com/shop/p-14589-ic693cbl300.aspx>

Provides the wiring diagrams and installation guidelines for this GE Series 90-30 module.

For further information, please contact Qualitrol Technical Support at

1-800-784-9385

[**support@qualitrol.com**](mailto:support@qualitrol.com)

IC693CBL300/301/302/312/313/314 I/O Bus Expansion Cables

(Includes Instructions for Building Custom Length Cables)

Description

I/O bus expansion cables (IC693CBL300, 301, 312, 313, 314), called “Wye cables,” have a single male 25-pin D connector on one end and a two-headed (one male, one female) 25-pin D connector on the other end as shown in (A) of the figure. The 50 foot (15m) (IC693CBL302) cable has a single male connector on the CPU baseplate end and a single terminated male connector on the expansion baseplate end. The 3 foot cable (IC693CBL300) can also be used as a WYE adapter cable to simplify building custom length cables (see the section “Cable Application Suggestions” later in this Chapter).

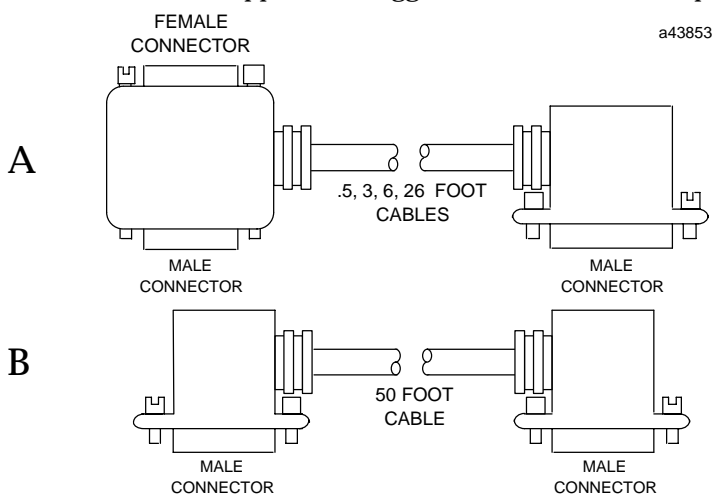

Figure 10-15. Detail of I/O Bus Expansion Cables

Cable Lengths

- IC693CBL300 3 feet (1 meter), *continuous shield*
- IC693CBL301 6 feet (2 meters), *continuous shield*
- IC693CBL302 or IC693CBL314 50 feet (15 meters), *continuous shield*
- IC693CBL312 0.5 feet (0.15 meters), *continuous shield*
- IC693CBL313 25 feet (8 meters), *continuous shield*

Function of Cables

The I/O Bus expansion cables are used to extend the I/O bus to expansion or remote baseplates in a Series 90-30 I/O system when additional I/O slots are needed or baseplates are required some distance from the CPU baseplate. The prewired I/O bus expansion cables can be used for connecting either expansion or remote baseplates. Where required cable length is not available in a standard cable, a custom cable must be built (see the section “Building Custom Length I/O Bus Expansion Cables” for detailed instructions).

Connecting the Cables

- Connect the single male connector to the 25-pin female connector on the right side of the CPU baseplate.
- Connect the male connector on the dual connector end of the cable to the 25-pin female connector on the first expansion baseplate.
- Connect the unused 25-pin female connector on the dual connector end of the cable to either the single male connector of a second I/O bus expansion cable to continue the I/O bus expansion chain, or to an I/O bus Terminator plug if this is the last cable in the expansion chain.

Important Notes About I/O Bus Expansion Cables

1. The maximum number of cables that can be included in an I/O expansion system is seven, and the total maximum cable length between the CPU baseplate and the last expansion baseplate is 50 feet (15 meters). The total maximum cable length between the CPU baseplate and the last remote baseplate is 700 feet (213 meters). Failure to observe these maximum cable lengths could result in erratic operation of the PLC system.
2. CPUs 350 – 364 support a maximum of seven I/O expansion cables. CPUs 331 – 341 support a maximum of four I/O expansion cables.
3. The 50 foot (15 meter) I/O bus expansion cable (IC693CBL302), which has a male connector on each end, has the I/O bus terminating resistors built into the end connector on the cable. If this cable is used, *you would not install a separate terminator block.*

Caution

I/O Bus Expansion cables should NOT be connected or disconnected with power applied to the I/O expansion baseplate(s). Unexpected PLC operation may result.

Cable Application Suggestions

In general, it is advantageous to use standard, factory-built cables, where possible, to save time and avoid wiring errors.

Using Standard Cables

- For connecting between baseplates (either between a CPU and expansion baseplate, between two expansion baseplates or between two remote baseplates) in the same cabinet when a standard length (0.5, 1, 2, 8, or 15 meters) will fit the need.
- As a Wye jumper for custom built point-to-point cables (IC693CBL300 is often used for this). This combination saves time since a point-to-point cable can be built much faster than a Wye cable. An example of this is shown in Figure 10-23.

Using Custom Built cables

- When you need a cable length not available in a standard size.
- When a cable must be routed through a conduit that is not large enough for a standard cable's connector to fit through.

Building Custom Length I/O Bus Expansion Cables

This section provides details needed to create custom length I/O Bus Expansion cables.

Two Types of Custom Built Cables

The two types are:

- **Point-to-Point** – these have a single male connector on one end and a single female connector on the other end. These are usually used with the IC693CBL300 which supplies the Wye connection. This combination saves time since a point-to-point cable can be built much faster than a Wye cable.
- **Wye** - these have a single male connector on one end and two connectors (one male and one female) on the other end.

Components Needed to Build Custom Length I/O Bus Expansion Cables

Note: the special two-headed Wye connector used on the standard Wye cables is not available as a separate component.

Item	Description
Cable:	Belden8107 only (no substitutes): Computer cable, overall braid over foil shield, twisted-pair 30volt/80°C (176°F) 24 AWG (.22 mm ²) tinned copper, 7 x 32 stranding Velocity of propagation = 70% † Nominal impedance = 100Ω
25 Pin Male Connector:	Crimp Plug = Amp 207464-1; Pin = Amp 66506-9 Solder Plug = Amp 747912-2
25 Pin Female Connector:	Crimp Receptacle = Amp 207463-2; Pin = Amp 66504-9 Solder Receptacle = Amp 747913-2
Connector Shell:	Kit - Amp 745833-5: Metal-plated plastic (plastic with nickel over copper) † Crimp ring - Amp 745508-1, split ring ferrule

† = Critical Information

‡ Vendor part numbers listed for user assembled cables are provided for reference only and do not suggest or imply that they are preferred. Any part meeting the same specification can be used.

Expansion Port Pin Assignments

The following table lists the expansion port pin assignments you will need when building remote cables. All connections between cables are point-to-point, that is, pin 2 of one end to pin 2 of the opposite end, pin 3 to pin 3, etc.

Table 10-2. Expansion Port Pin Assignments

Pin Number	Signal Name	Function
16	DIODT	I/O Serial Data Positive
17	DIODT/	I/O Serial Data Negative
24	DIOCLK	I/O Serial Clock Positive
25	DIOCLK/	I/O Serial Clock Negative
20	DRSEL	Remote Select Positive
21	DRSEL/	Remote Select Negative
12	DRPERR	Parity Error Positive
13	DRPERR/	Parity Error Negative
8	DRMRUN	Remote Run Positive
9	DRMRUN/	Remote Run Negative
2	DFRAME	Cycle Frame Positive
3	DFRAME/	Cycle Frame Negative
1	FGND	Frame Ground for Cable Shield
7	0V	Logic Ground

I/O Expansion Bus Termination

When two or more baseplates are cabled together in an expansion system, the I/O expansion bus must be properly terminated. The I/O bus *must be terminated* at the last baseplate in an expansion system. Each signal pair is terminated with 120 ohm, 1/4 watt resistors wired between the appropriate pins, as follows (see the above table, also):

pins 16 - 17; 24 - 25; 20 - 21; 12 - 13; 8 - 9; 2 - 3

The I/O bus termination can be done one of the following ways:

- By installing an *I/O Bus Terminator Plug*, catalog number IC693ACC307, on the last expansion baseplate (local expansion baseplate or remote baseplate) in the system. The Terminator Plug has a resistor pack physically mounted inside of a connector. The I/O Bus Terminator Plug is shipped with each baseplate; only the last baseplate in the expansion chain can have the I/O Bus Terminator Plug installed. Unused I/O Bus Terminator Plugs can be discarded or saved as spares.
- If an expansion system has only one expansion baseplate, the I/O bus can be terminated by installing as the last cable, the 50 foot (15 meter) I/O Expansion cable, catalog number IC693CBL302 or IC693CBL314. These cables have the termination resistors installed in the end that connects to the expansion baseplate connector.
- You can also build a custom cable with termination resistors wired to the appropriate pins for installation at the end of the bus.

Shield Treatment

All GE Fanuc factory made cables are made with a *continuous*, or 100% shield. This means that the braided cable shield is connected to the metal shell of the connector around the entire perimeter of the connector. This provides a low impedance path to frame ground for any noise energy that is coupled onto the cable shield.

For custom length cables made per Figure 10-18, the best noise immunity is achieved when using a metallized connector cover that makes contact with the cable's braided and foil shielding and with the connector shell on the terminating end.

Note

It is **not sufficient** to only solder the drain wire to the connector shell. It is required that the cable's shield be continuous across the entire length of the cable, including at the terminations. The figure below shows the recommended method for folding the braided shield back before inserting the cable into a metallized cover.

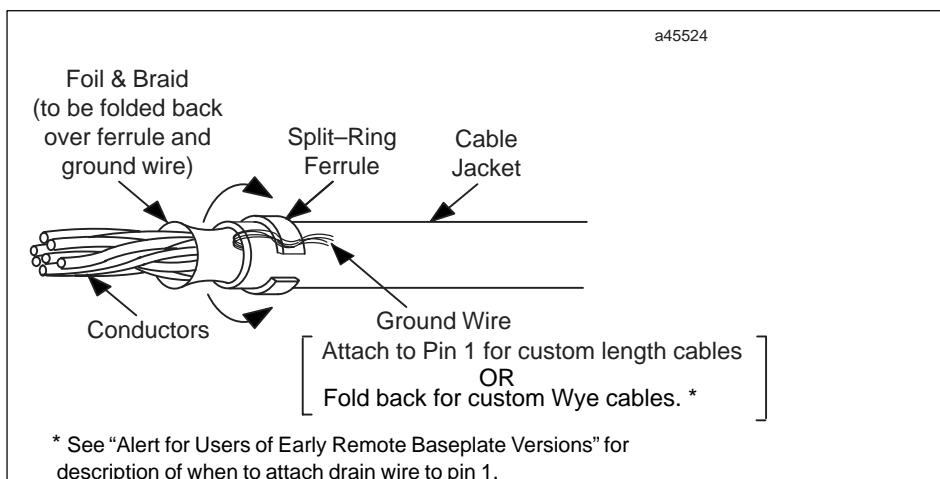

Figure 10-16. How to use Split-Ring Ferrules for Foil and Braided Cable Shield

For typical industrial applications, all expansion and remote baseplate cables can be made with plastic shell covers and should be wired as shown in Figure 10-19. In either case, pin 1 should be wired into both ends of the custom length cable and the recommendations listed below should be followed for the Wye cables treatment in the remote (IC693CHS392/399) baseplates.

When using 100% shielded cables all local (CPU and expansion) baseplates in the system must be solidly referenced to the same ground point or a potential difference between baseplates could disturb signal transmission.

Alert for Users of Early Remote Baseplate Versions

In early remote baseplates versions, IC693CHS393E (and earlier) and IC693CHS399D (and earlier), it is necessary to remove pin 1 of the mating cable where the cable plugs into the baseplate. This means that when using a factory made Wye cable, such as IC693CBL300, you must break pin 1 out of the male end where it plugs into the remote

baseplate before using it with one of these baseplates. *Custom built Wye cables for these baseplates should be built using Figure 10-20.*

Remote baseplates IC693CHS393F (and later) and IC693CHS399E (and later) have a change inside the baseplate which eliminates the need to remove pin 1 from the mating cable. When using factory made Wye cable with these baseplates, it is **not** necessary to remove pin 1 from the cable. Custom built Wye cables for these baseplates can be made using either Figure 10-20 or Figure 10-21. Figure 10-21 shows how the standard (factory made) Wye cables are made.

By removing pin 1 in custom built Wye cables made for the earlier versions of remote baseplates, the pin 7 (0V) signal reference originates in the main (CPU) baseplate. In these earlier versions of the remote baseplates, pin 1 was tied to pin 7 (0V) and also AC coupled to the remote frame ground. When using these baseplates in combination with the 100% shielded Wye cables, the pin 7 (0V) reference would be improperly DC coupled to the remote frame ground through the D-subminiature connector shell, which is DC coupled to the remote frame ground.

In the remote baseplates IC693CHS393F (and later) and IC693CHS399E (and later), the pin 1 shield signal is DC coupled to the remote frame ground and *not* attached to pin 7 (0V). This allows the best noise immunity by providing a good continuous cable shield, and still allows the pin 7 (0V) signal reference to originate in the CPU baseplate without the need for removing pin 1 in any factory or custom built cable. The D-subminiature connector shell is still DC coupled to the remote frame ground.

Making a 100% Shielded Cable

Use the following steps to build a 100% shielded cable:

1. Strip approximately 5/8 inch of insulation from your custom cable to expose the shield.
2. Remove the male Pin 1 from any connector plugging directly into an older version remote baseplate (IC693CHS393E, IC693CHS399D, or earlier).
3. Put split-ring ferrule over cable insulation (Figure 10-17).
4. Fold the shield back over top of the cable insulation and ferrule.
5. Place the collar of the metal hood over top of the folded shield and securely clamp the hood.
6. Test your cable for continuity between both connector shells. Connect an ohmmeter between the shells and flex the cable at both ends. If the metalized connector hood is not making proper contact with the cable shield at either end, the connection will show intermittent continuity on the ohmmeter.
7. Plug the metal hooded cable onto a remote baseplate expansion port connector or into a GE Fanuc WYE cable and securely tighten the two screws. Installing and tightening the screws will electrically connect the shield to the remote baseplate frame ground, which should in turn should be connected to earth ground as instructed in the "Installation" chapter, under the heading "Baseplate Safety Grounding."

Wiring Diagrams

The following wiring diagrams show the wiring configuration for I/O expansion system cables. Wiring diagrams are provided for both point-to-point cables and Wye cables.

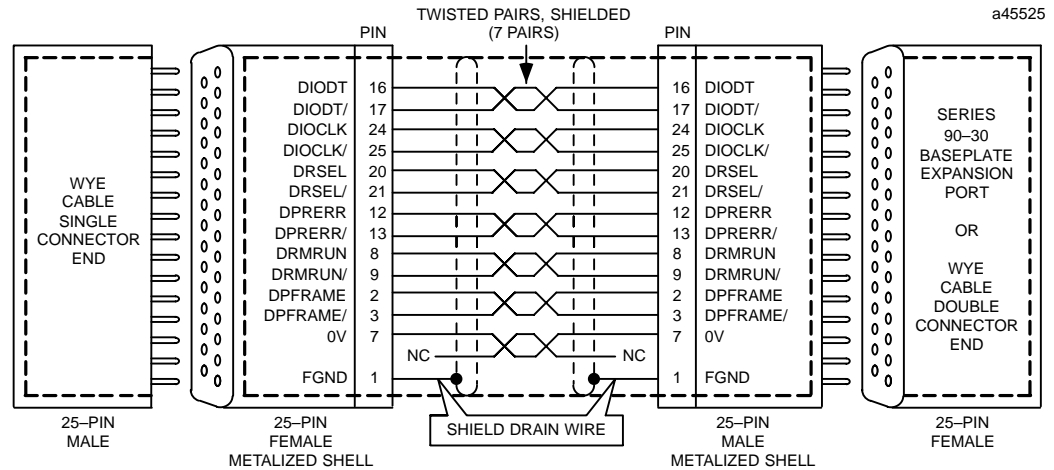

NOTE:
 Bold dashed line shows continuous (100%) shielding when metallized shell connectors are plugged together.

Figure 10-17. Point-To-Point Cable Wiring for Continuous Shield Custom Length Cables

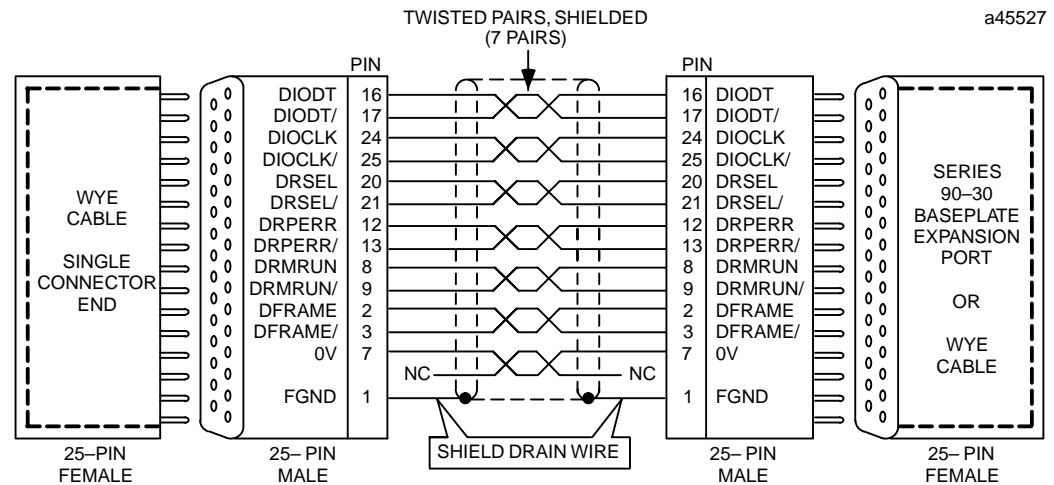
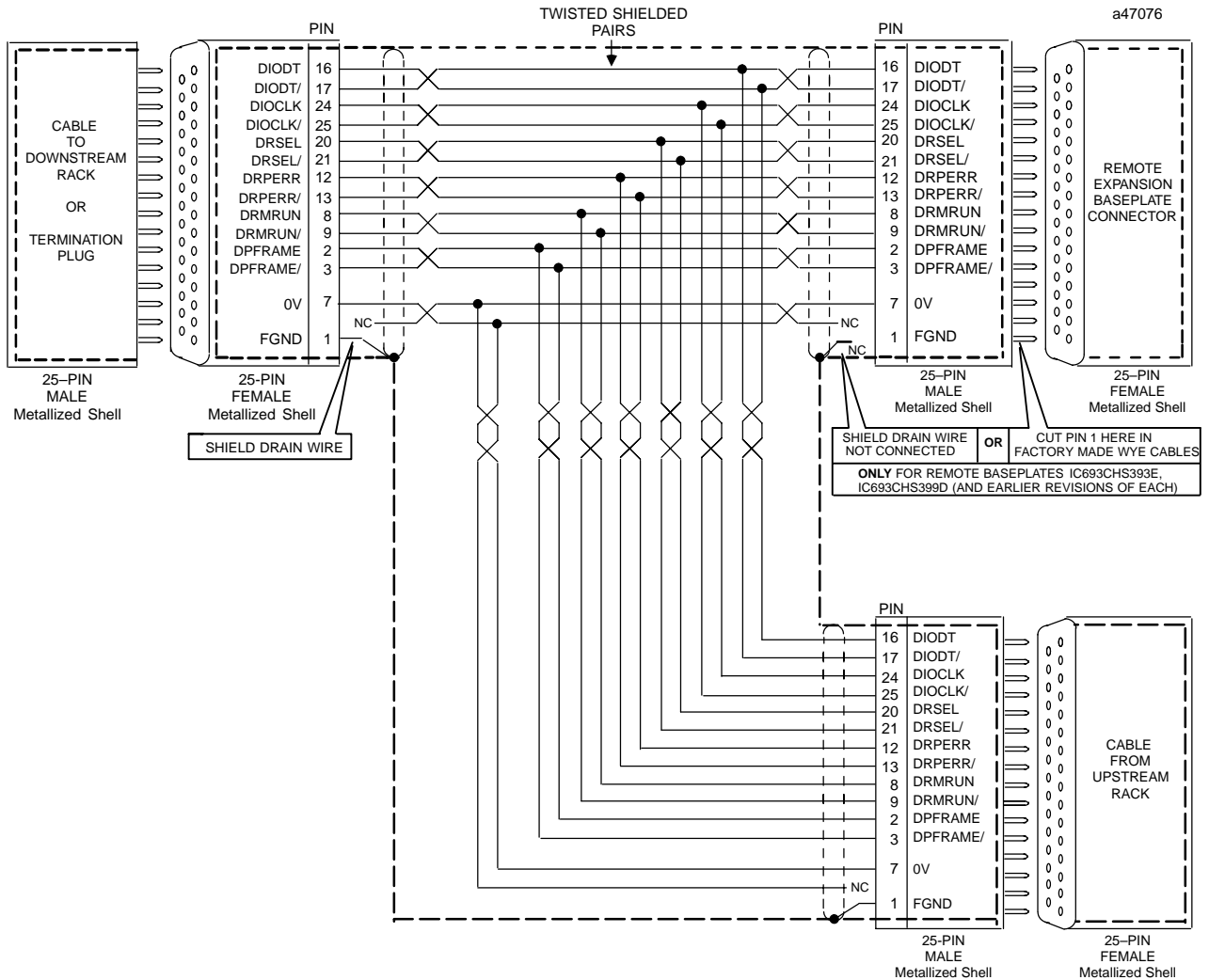

Figure 10-18. Point-To-Point Cable Wiring Diagram for Applications Requiring Less Noise Immunity



NOTE:
 Bold dashed line shows continuous (100%) shielding when metallized shell connectors are plugged together.

Figure 10-19. Earlier Versions of Remote Baseplate Custom WYE Cable Wiring Diagram

Note

In remote baseplates, IC693CHS393E (and earlier) and IC693CHS399D (and earlier), it is necessary to remove pin 1 of the mating cable where the cable plugs into the baseplate. This means that when using a factory made Wye cable, IC693CBL300, you must break pin 1 out of the male end where it plugs into the remote baseplate before using it with one of these baseplates. *Custom built Wye cables for these baseplates should be built using Figure 10-20.* See the section "Alert to Users of Early Remote Baseplate Versions" for more details.

Remote baseplates IC693CHS393F (and later(and IC693CHS399E (and later) have a change inside the baseplate which alleviates the need to remove pin 1 from the mating cable. When using factory made Wye cable with these baseplates, it is **not** necessary to remove pin 1 from the cable. Custom built Wye cables for these baseplates can be made using either Figure 10-20 or Figure 10-21. Figure 10-21 shows how the factory made Wye cable are made.

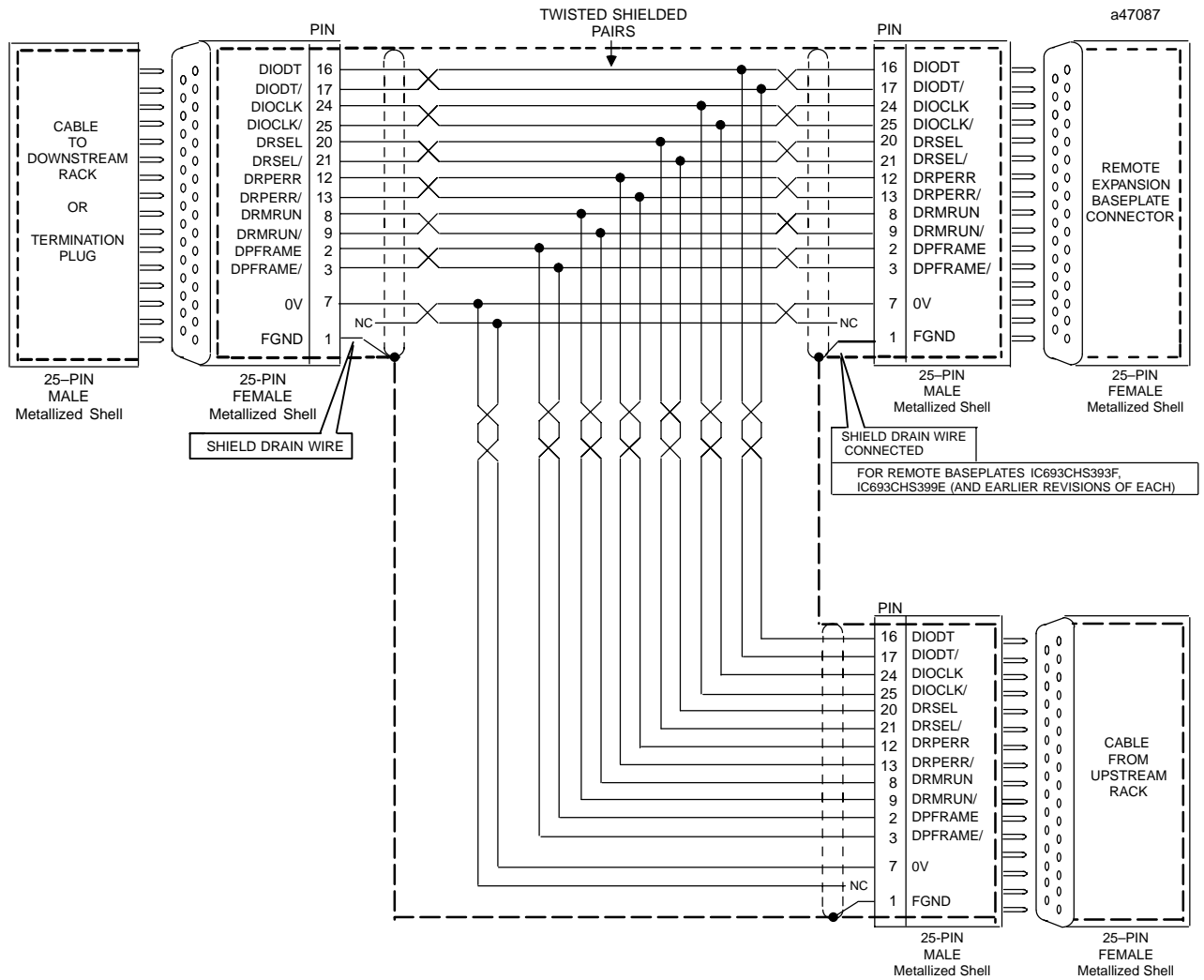

NOTE:
 Bold dashed line shows continuous (100%) shielding when metallized shell connectors are plugged together.

Figure 10-20. Current Remote baseplate (IC693CHS393/399) Custom Wye Cable Wiring Diagram

Application Examples

Expansion System Cable Connections

The following example shows cable connections in a system that has expansion baseplates but no remote baseplates.

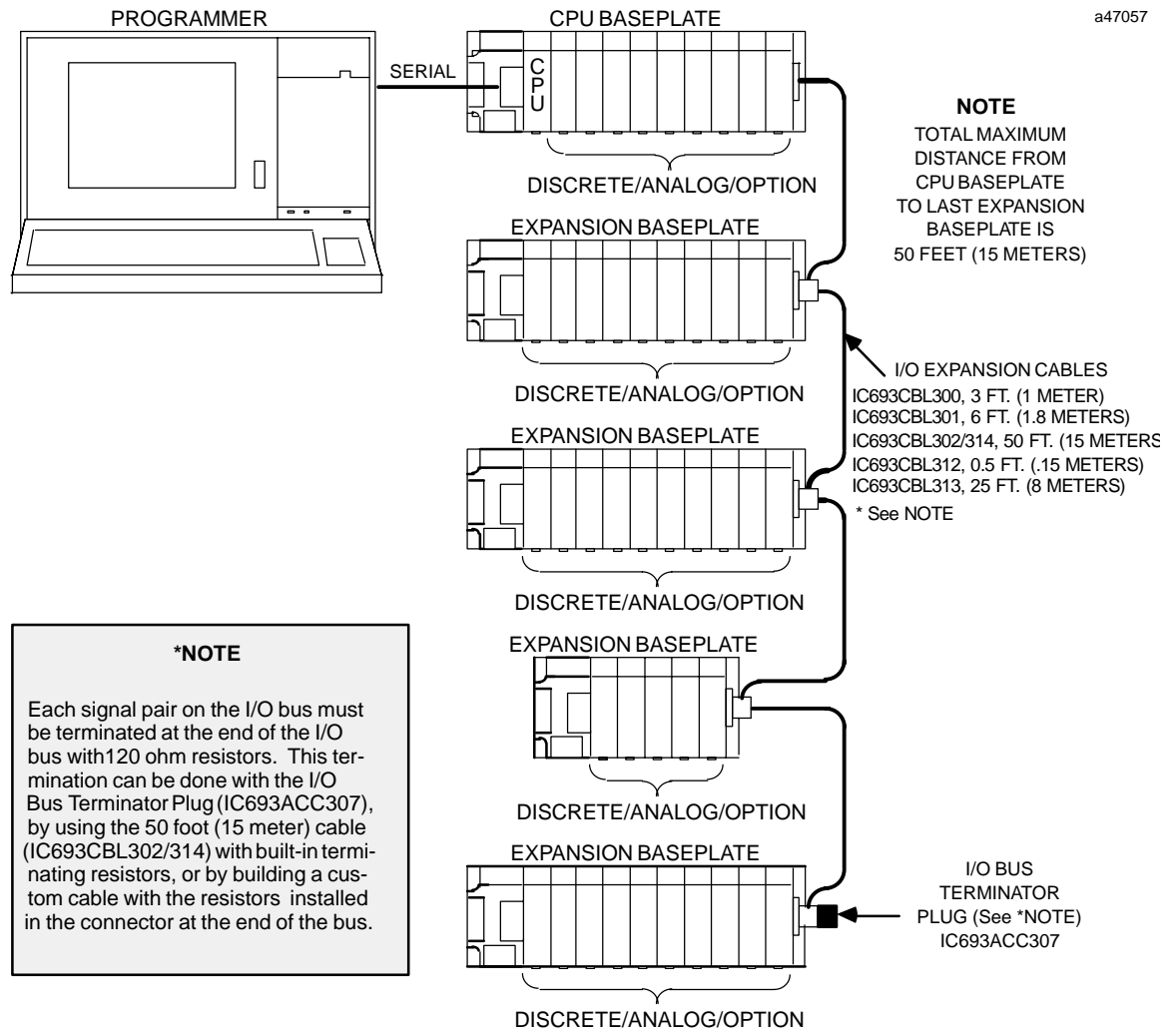

Figure 10-21. Example of Connecting Expansion Baseplates

Remote and Expansion System Cable Connection Example

The following example shows cable connections in a system that includes both remote and expansion baseplates. A system can have a combination of remote and expansion baseplates as long as the distance and cable requirements are followed.

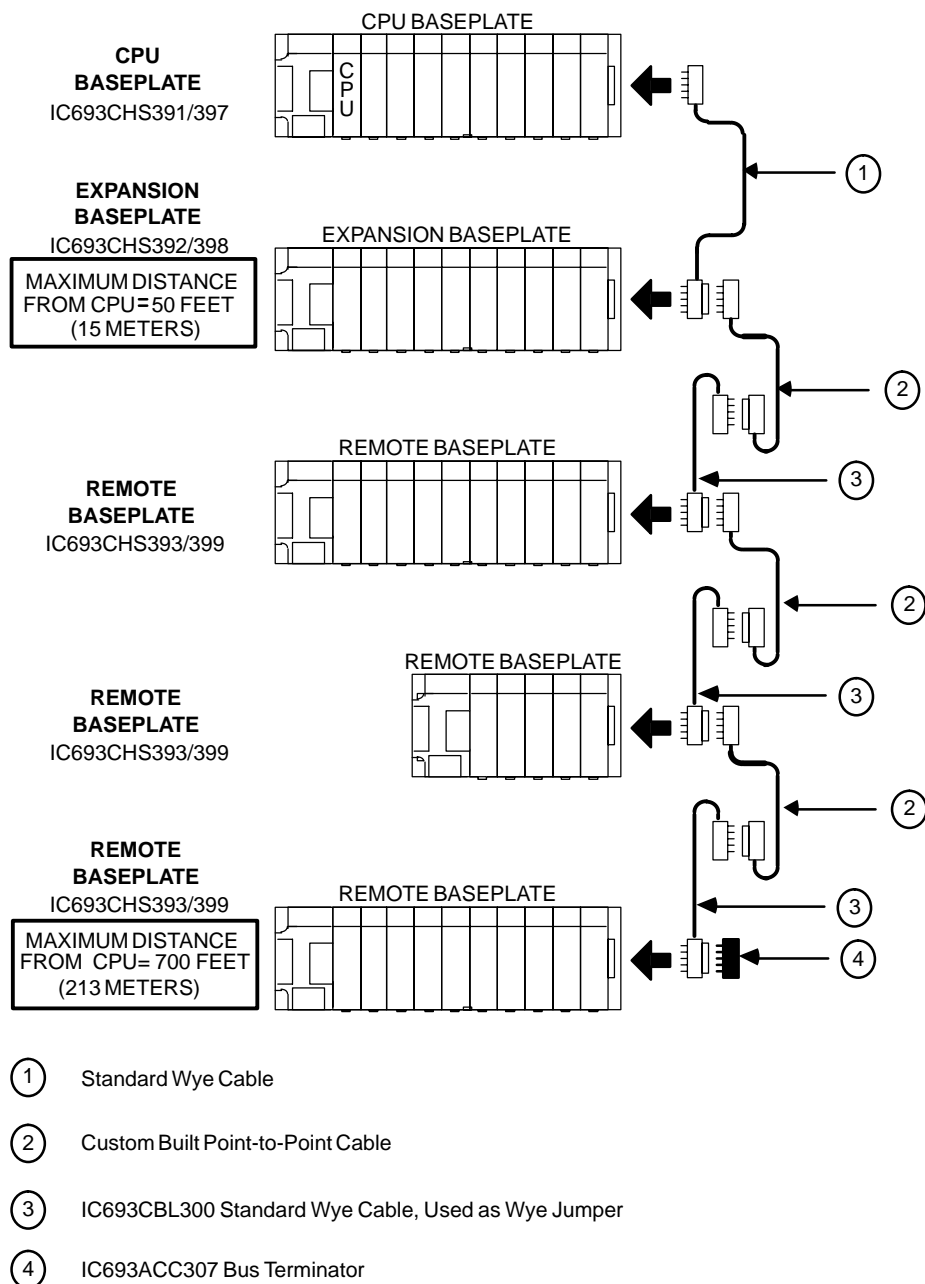

Figure 10-22. Example of Connecting Expansion and Remote Baseplates