



This Datasheet for the

IC693DSM314

Series 90-30 DSM314 Motion Controller, 1-2 Axis Digital Servo or 1-4 Axis Analog Servo

<http://www.qualitrol.com/shop/p-14642-ic693dsm314.aspx>

Provides the wiring diagrams and installation guidelines for this GE Series 90-30 module.

For further information, please contact Qualitrol Technical Support at

1-800-784-9385

support@qualitrol.com

IC693DSM314 Motion Mate Digital Servo Module (DSM314)

The Motion Mate DSM314 is a high-performance motion control module that is highly integrated with the logic solving and communications functions of the Series 90-30 PLC. In digital mode, this module controls GE Fanuc digital servos. In analog mode, this module controls servos with an analog command input, such as the GE Fanuc SL Series Servos, or third party analog servos.

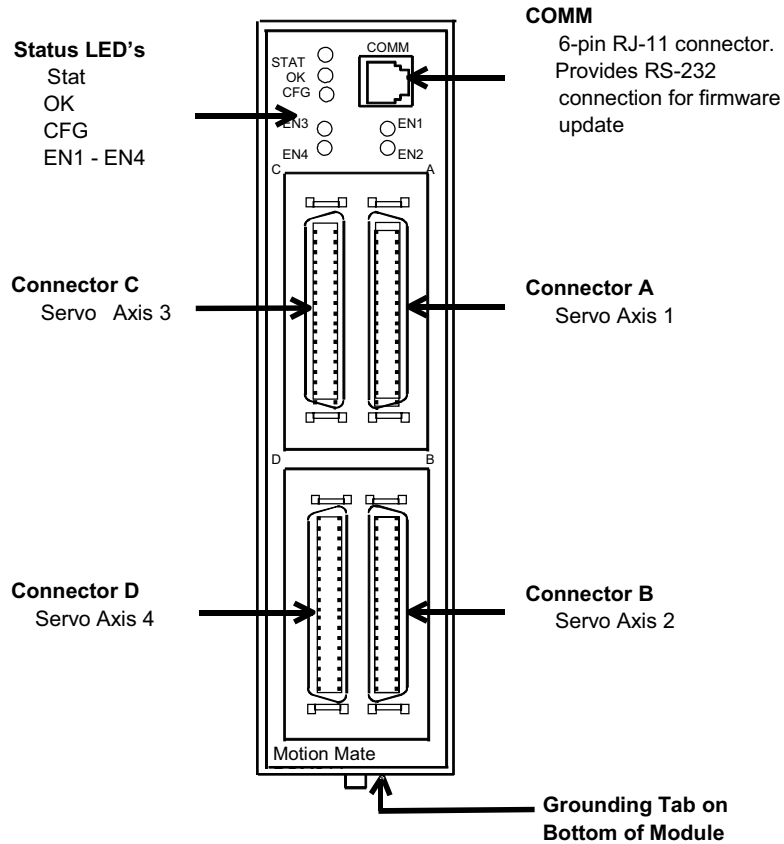

Figure 8-13. Motion Mate DSM314 Module

Features

- Digital Signal Processor (DSP) control of GE Fanuc Servos
- Block Processing time under 5 milliseconds
- Velocity Feed Forward and Position Error Integrator to enhance tracking accuracy
- High resolution of programming units
 - Position: -536,870,912...+536,870,911 User Units
 - Velocity: 1 ... 8,388,607 User Units/sec
 - Acceleration: 1 ... 1,073,741,823 User Units/sec/sec
- Simple and powerful motion program instruction set
- Simple 1- to 4-axis motion programs. Multi-axis programs using Axes 1 and 2 may utilize a synchronized block start.
- Non-volatile storage for 10 programs and 40 subroutines created with VersaPro software (Version 1.1 or later).
- Compatible with Series 90-30 CPUs equipped with firmware release 10.0 or later (will not work with CPUs 311 – 341 and 351).
- Single point of connection for all programming and configuration tasks, including motion program creation (Motion Programs 1 – 10) and Local Logic programming. All programming and configuration is loaded through the PLC's programming communications port. In turn, the CPU loads all configuration, motion programs, and Local Logic programs to the DSM314 across the PLC backplane.
- User scaling of programming units (User Units) in both Standard and Follower modes.
- DSM314 firmware, stored in Flash memory, is updated via its front panel COMM port. Firmware update kits provide firmware and Loader software on floppy disk. Firmware is also available for download on the GE Fanuc web site (<http://www.gefanuc.com/support>).
- Recipe programming using command parameters as operands for Acceleration, Velocity, Move, and Dwell Commands
- Automatic Data Transfer between PLC tables and DSM314 without user programming
- Ease of I/O connection with factory cables and terminal blocks
- Electronic CAM capability, starting with Firmware Release (Version) 2.0
- Control of GE Fanuc α Series and β Series Digital servos, SL-Series servos, or third party servos with analog velocity command or analog torque command interface.
- Home and overtravel switch inputs for each Servo Axis
- Two Position Capture Strobe Inputs for each axis can capture axis and/or master position with an accuracy of +/-2 counts plus 10 microseconds of variance.
- 5V , 24V and analog I/O for use by PLC
- Incremental Quadrature Encoder input on each axis for Encoder/Analog mode
- Quadrature Encoder input for Follower Master axis
- 13 bit Analog Output can be controlled by PLC or used as Digital Servo Tuning monitor
- High speed digital output (four each 24V and four each 5V) via on-board Local Logic control

IC693DSM314 Documentation

- GFK-1742, *Motion Mate DSM314 for Series 90-30 PLC User's Manual*

Related servo manuals:

- GFK-1581, *SL Series Servo User's Manual*
- GFH-001, *Beta Series Servo Products Specification Guide*
- GFZ-65192EN, *Alpha Series Servo Amplifier (SVU) Descriptions Manual*
- GFZ-65162E, *Control Motor Amplifier, Alpha Series*
- GFZ-65142E, GFZ-65150E, GFZ-65165E, *Alpha Series Servo Motor Manuals*