



This Datasheet is for the

[IC693MDL241](#)

24 Volt AC/DC Positive/Negative Logic Input, 16 Point

<http://www.qualitrol.com/shop/p-14650-ic693mdl241.aspx>

Provides the wiring diagrams and installation guidelines for this GE Series 90-30 module.

For further information, please contact Qualitrol Technical Support at

1-800-784-9385

support@qualitrol.com

24 Volt AC/DC Positive/Negative Logic Input, 16 Point IC693MDL241

The *24 volt AC/DC Positive/Negative Input* module for the Series 90-30 Programmable Logic Controller provides 16 input points in one group with a common power input terminal. This input module is designed to have either positive or negative logic characteristics in the DC input mode. This input module is designed to function with AC or DC user inputs. Input characteristics are compatible with a wide range of user-supplied input devices, such as pushbuttons, limit switches, and electronic proximity switches. Current into an input point results in a logic 1 in the input status table (%I). Power to operate the field devices can be supplied by the user, or the Isolated +24 VDC output on the power supply (bottom two power supply terminals) can be used to power a limited number of DC inputs.

LED indicators which provide the ON/OFF status of each point are located at the top of the module. This LED block has two horizontal rows with eight green LEDs in each row; the top row labeled A1 through 8 (points 1 through 8) and the bottom row labeled B1 through 8 (points 9 through 16). An insert goes between the inside and outside surface of the hinged door. The surface towards the inside of the module (when the hinged door is closed) has circuit wiring information, and circuit identification information can be recorded on the outside surface. The outside left edge of the insert is color-coded blue to indicate a low-voltage module. This module can be installed in any I/O slot of a 5 or 10-slot baseplate in a Series 90-30 PLC system.

Table 6-4. Specifications for IC693MDL241

Rated Voltage	24 volts AC or 24 volts DC
Input Voltage Range	0 to +30 volts DC or 0 to +30 volts AC, 50/60 Hz
Inputs per Module †	16 (one group with a single common)
Isolation	1500 volts between field side and logic side
Input Current	7 mA (typical) at rated voltage
Input Characteristics	
On-state Voltage	11.5 to 30 volts AC or DC
Off-state Voltage	0 to +4 volts AC or DC
On-state Current	3.2 mA minimum
Off-state Current	1 mA maximum
On response Time	12 ms typical
Off response Time	28 ms typical
Power Consumption: 5V	80 mA (all inputs on) from 5 volt bus on backplane
Power Consumption: 24V	125 mA from the Isolated 24 volt backplane bus or from user supplied power

† Number of inputs on is dependent upon ambient temperature as shown in figure 6-9.

Refer to Appendix B for product standards and general specifications.

IC693MDL241 Input Module Field Wiring Information

The following figure provides wiring information for connecting user supplied input devices and power source to the 24 volt AC/DC positive/negative logic input module.

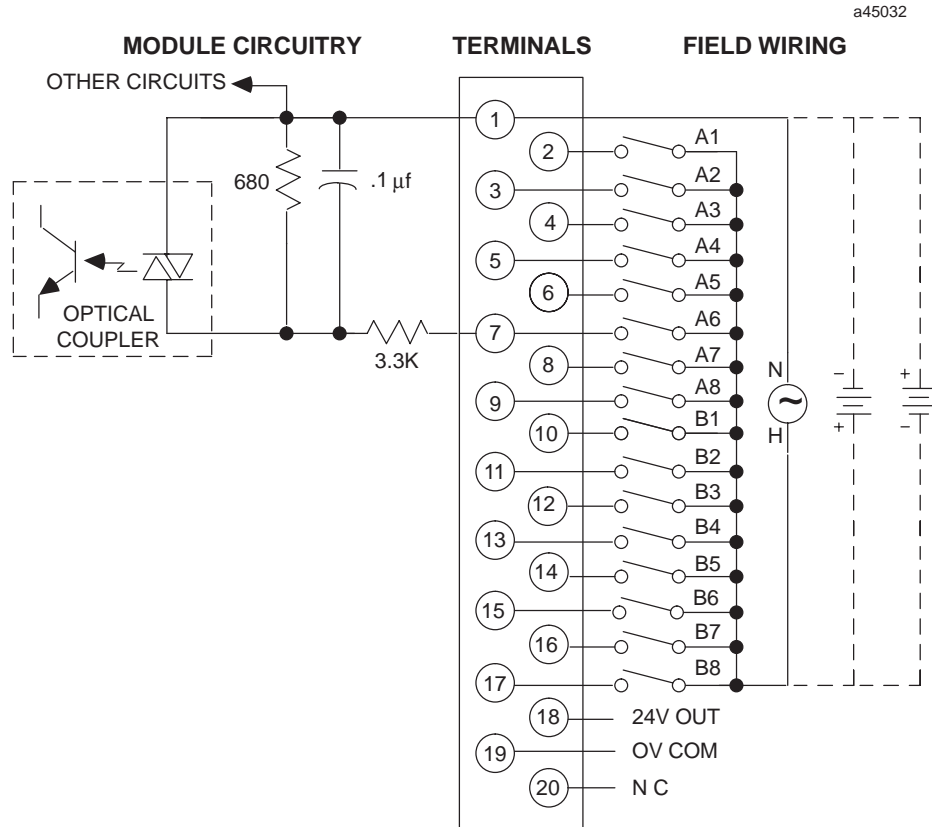

Figure 6-5. Field Wiring - 24 Volt AC/DC Pos/Neg Logic Input Module - IC693MDL241

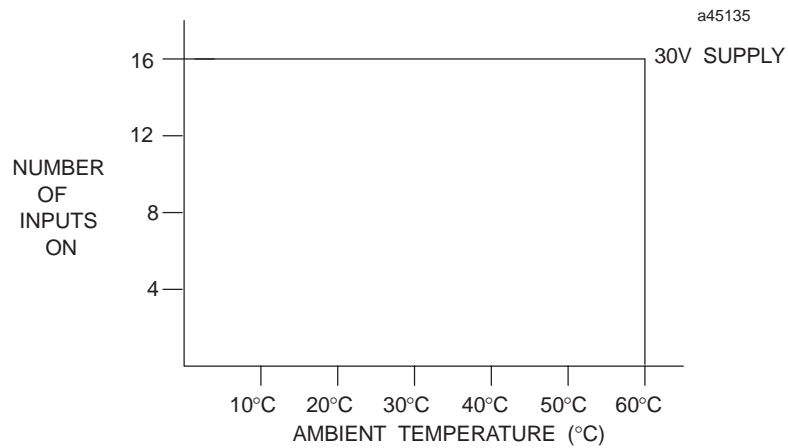

Figure 6-6. Input Points vs. Temperature for IC693MDL241