



This Datasheet is for the

[IC693MDL751](#)

12/24 Volt DC Positive Logic Output, 32 Point

<http://www.qualitrol.com/shop/p-14673-ic693mdl751.aspx>

Provides the wiring diagrams and installation guidelines for this GE Series 90-30 module.

For further information, please contact Qualitrol Technical Support at

1-800-784-9385

support@qualitrol.com

12/24 Volt DC Positive Logic Output, 32 Point IC693MDL751

The *12/24 volt DC Positive Logic Output* module for the Series 90-30 Programmable Logic Controller provides 32 outputs in four groups of eight with two common pins for each group. The Output module is designed to have positive logic characteristics in that it sources current to the loads from the user common or positive power bus. The output device is connected between the negative power bus and the module output. The output characteristics are compatible with a wide range of user-supplied load devices, such as motor starters, solenoids, and indicators. Power to operate the field devices must be supplied by the user.

Connections from the output circuits are made to the user's output devices through a 50-pin connector mounted on the front of the module.

This module does not have LED indicators to indicate circuit status. This output module can be installed in any I/O slot of a 5 or 10-slot baseplate in a Series 90-30 PLC system.

Table 7-22. Specifications for IC693MDL751

Rated Voltage	12/24 volts DC
Output Voltage Range	12 to 24 volts DC (+20%, -15%)
Outputs per Module	32 (four groups of eight outputs each)
Isolation	1500 volts between field side and logic side
Output Current	0.3 amps maximum per point 2 amps maximum (each common)
Output Characteristics	
Output Voltage Drop	0.24 volts maximum
Off-state Leakage	0.1 mA maximum
On Response Time	2 ms maximum
Off Response Time	2 ms maximum
Internal Power Consumption	21 mA (all outputs on) from 5 volt bus on backplane

Refer to Appendix B for product standards and general specifications.

Wiring to Field Devices

- **Direct Method** – This method uses cables that have a mating female connector on the module end and stripped and tinned wires on the other end. You can purchase a pre-wired cable, either catalog number IC693CBL308 (3 feet/1 meter) or catalog number IC693CBL309 (6 feet/2 meters) or, if required for your application, build your own cables. Refer to the IC693CBL308/309 data sheet in Appendix C of this manual for cable information.
- **Using a Weidmuller Terminal Block** – You may purchase a Weidmuller #912263 terminal block from your electronics dealer to use with a GE Fanuc prewired cable. GE Fanuc Cables IC693CBL306 (3 feet/1meter) or IC693CBL307 (6 feet/2 meters) have connectors on each end. These connect from the module connector to a connector on the DIN-rail mounted Weidmuller terminal block. Appendix C has a data sheet for these cables, which includes a figure showing how they connect between the module and the Weidmuller terminal block.

IC693MDL751 Output Module Field Wiring Information

The following figure provides wiring information for connecting user supplied load devices and power source to the 12/24 volt DC positive logic output module.

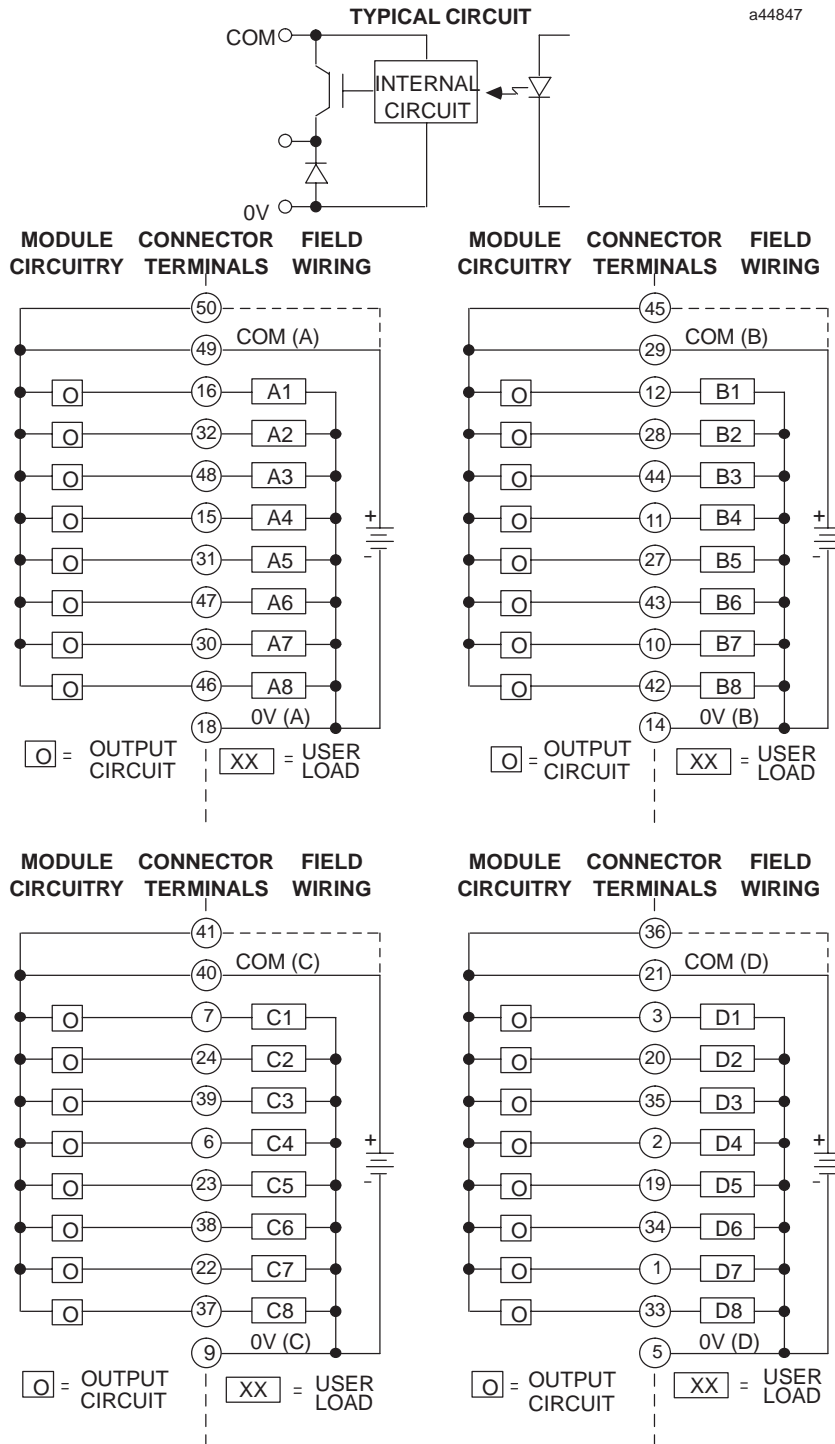

Figure 7-38. Field Wiring - IC693MDL751 32 Point Output Module