



This Datasheet for the

IC697BEM733

Series 90-70 Genius Remote I/O Scanner.

<http://www.qualitrol.com/shop/p-14756-ic697bem733.aspx>

Provides the wiring diagrams and installation guidelines for this GE Series 90-30 module.

For further information, please contact Qualitrol Technical Support at

1-800-784-9385

support@qualitrol.com

Bus Expansion Modules

IC697BEM733/735

GFK-0539C
August 1997

Remote I/O Scanner

The IC697 Remote I/O Scanner (IC697BEM733/735) is an intelligent module that mounts in a remote IC697 rack, and interfaces IC697 I/O modules to an IC66* bus.

Features

- Can be located up to 7500 feet (2275 meters) from controller.
- Supports standard IC697 discrete and analog I/O modules.
- Supports PCM, ADS, and analog expander modules.
- Handles up to 128 bytes of inputs and 128 bytes of outputs per remote drop.
- Configurable with MS-DOS® programming software configuration function or with an IC66* Hand-held Monitor.
- Compatible with all types of IC66* host.
- Supports both CPU and IC66* bus redundancy.†
- Each remote drop can include up to eight racks†, with a Remote I/O Scanner located in rack 0.
- Up to 30 remote drops can be located on the same IC66* bus.

Together, a Remote I/O Scanner and the modules it serves make up a remote drop on the IC66* bus. A

remote drop can consist of up to eight racks, linked by Bus Transmitter and Bus Receiver modules. 9-slot and/or 5-slot IC697 racks can be used. The maximum distance from the first rack to the last rack in a remote drop is 50 feet (15 meters).

The Remote I/O Scanner can handle any mix of discrete and analog inputs and outputs up to a total of 1024 discrete inputs and 1024 discrete outputs, or 64 analog inputs and 64 analog outputs (regardless of the number of racks in the remote drop). A remote drop can include all presently-available IC697 discrete modules, analog modules, and analog expander modules. Bus Transmitter, Bus Receiver, PCM, and ADS modules can also be placed in a remote drop. A remote drop cannot have any I/O module interrupts, bus controllers, communications modules, or other modules that depend on COMREQ instructions for their operations.

The Remote I/O Scanner is ideally suited for use in an IC697 PLC system. However, any type of PLC or computer capable of controlling an IC66* bus can be used as the host. Suitable hosts include IC660 PLCs, IC655 PLCs, and computers equipped with a PCIM (Personal Computer Interface Module), QBIM (Q-Bus Interface Module), or a third-party GENI-based interface.

† Remote I/O Scanner IC697BEM733/735B or later required.
* IC660 or IC661 products.

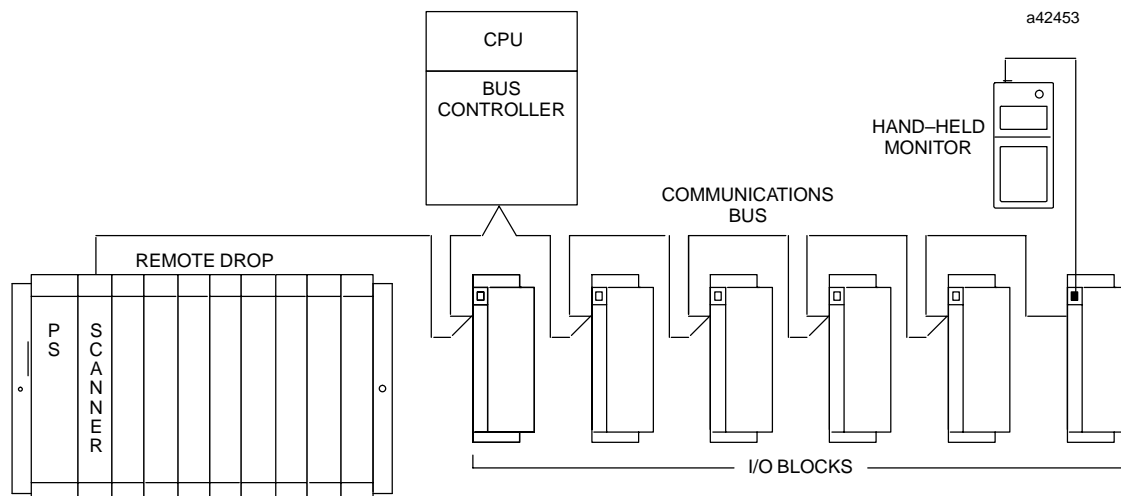

© MS-DOS is a registered trademarks of Microsoft Corporation.

GFK-0539C
August 1997

Remote I/O Scanner

Module Description

The Remote I/O Scanner consists of a single circuit board, with a hinged door which serves as a faceplate. The module does not require batteries; the faceplate battery holder is not used.

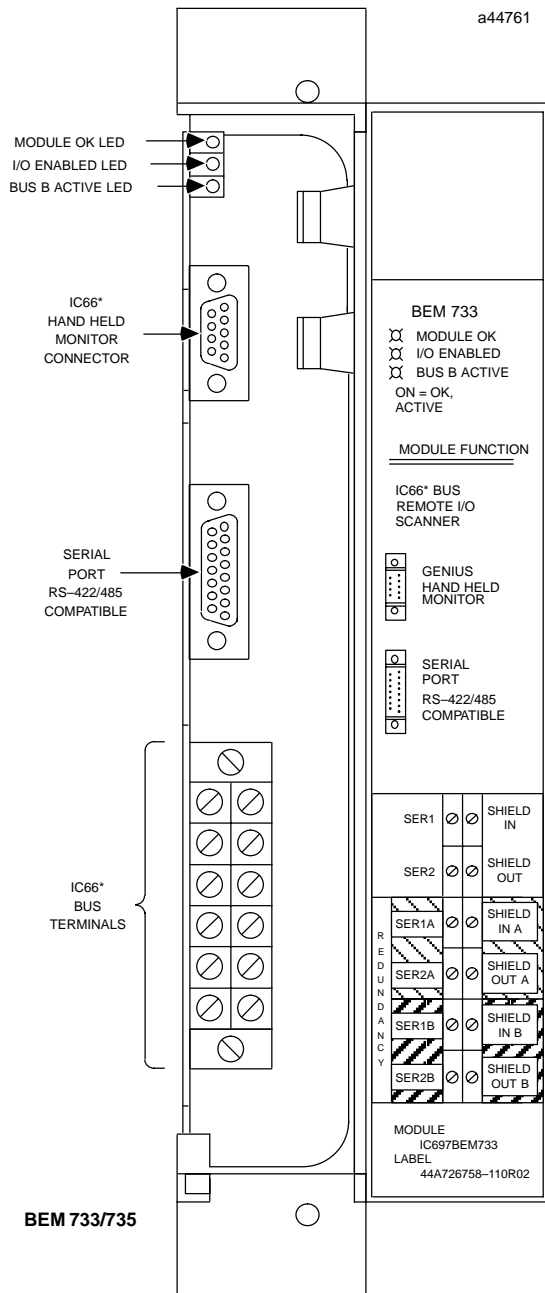

LEDs

The Remote I/O Scanner has three LEDs that show through the transparent portion at the top of the door.

Module OK lights when the module has passed its powerup diagnostic tests. If this LED flashes, it indicates a problem. If this LED is off, there is a fatal error that will cause the Remote I/O Scanner to go to stop/faulted mode.

I/O Enabled lights when the Remote I/O Scanner is receiving output data from the CPU. If this LED flashes, either I/O data is forced or there is a Device Number conflict.

Bus B Active on a dual (redundant) bus, this LED lights when Bus B is active.

The following table summarizes the LED indications.

Module OK	I/O Enabled	Meaning
On	On	Normal Operation
Blinking	On	Fault detected
On	Blinking	I/O data forced
Alternate blinking	Alternate blinking	Fault detected, and I/O data forced
Synchronous blinking	Synchronous blinking	Device Number conflict
On	Off	Outputs not being updated from CPU
Off	Off	No power or fatal error

Connectors

- 9-pin male D Connector: the upper connector. Used for attaching an IC66* Hand-held Monitor.
- 15-pin female D Connector: the center connector is an RS-422 compatible RS-485 serial port, for direct connection of a serial programmer or for connection to a multidrop communications network.
- The IC66* bus terminal strip is attached to the connector at the bottom of the module. Because the terminal strip is removable, it is possible to service or replace the module while the system is operating without disrupting bus communications.

Remote I/O Scanner

GFK-0539C
August 1997

Compatibility

This Remote I/O Scanner is compatible with:

IC66* Hand-held Monitor:

version 4.0 (IC660HHM501G) or later.

For an IC697 PLC: CPU firmware release 2.0 or later, MS-DOS programming software release 3.0 or later, Bus Controller release 3.0 or later.

For an IC600 PLC: CPU rev. 105 or later, MS-DOS programming software release 4.02 or later, Bus Controllers (IC660CBB902 or 903) must be version 1.7 or later.

For an IC655 PLC: CPU rev. 4.0 or later, MS-DOS programming software release 2.01 or later, any version Bus Controller.

For a Host Computer: any version PCIM or QBIM.

Required Equipment

The following additional equipment may be required to use a Remote I/O Scanner:

- At least one IC697 5-slot or 9-slot remote rack with power supply.
- If the parallel version of MS-DOS programming software will be used, the remote drop must include a Bus Transmitter Module (IC697BEM713).
- If the remote drop will be part of a multidrop network, which cannot be guaranteed to be on the same electrical ground and served by the same phase on the mains, isolation must be provided separately for each CPU and Remote I/O Scanner. If isolation is required, use the RS-422 Isolated Repeater/RS-232 converter (catalog number IC655CCM590), or equivalent product.

Operation

The Remote I/O Scanner scans the I/O modules in the remote drop in the same manner as an IC697 CPU scans the I/O modules in the PLC. At powerup, scanning begins immediately unless a fatal diagnostic error occurs. All I/O in a remote drop, except those that are forced, default to Off at powerup. I/O that are forced at powerup start in the forced state or value.

During operation, the Remote I/O Scanner first scans the input modules in rack and slot order, storing the input data in its own %I and %AI memories. Then, it scans the output modules in rack and slot order, send-

ing them the most recent output data from its own %Q and %AQ memories.

IC66* Communications with the Host

After the Remote I/O Scanner completes a successful login with the host, it begins data transfer on the IC66* bus. When the Remote I/O Scanner receives the IC66* bus communications token, it transmits the most recent input data from the configured portion of its %I and %AI memories. When the host's bus controller has the communications token, it sends the Remote I/O Scanner new output data from the host. The Remote I/O Scanner places the output data into the configured portion of its %Q and %AQ memories.

Remote Drop Installation

The *Remote I/O Scanner User's Manual* gives installation procedures for the racks, power supplies, and modules in a remote drop. Be sure to follow the grounding procedures carefully.

Module Locations

A remote drop can consist of up to eight IC697 racks, numbered 0 to 7. Rack numbers are configured by setting the jumpers located on the rack backplane. See the *User's Manual* for instructions. Before installing modules in a remote drop, determine where to place them.

- The Remote I/O Scanner must be located in rack 0, slot 1 (remote drop).
- A Bus Transmitter can be located in any slot of rack 0; however, there must be no empty slots between the Bus Transmitter and the Remote I/O Scanner. Slot 2 is recommended.
- In a multiple-rack remote drop, a Bus Receiver must be located in slot 1 of each expansion rack.
- A high-level analog input module and its associated expander modules must be installed in the same rack of a remote drop. *The high-level analog input module must be in the lowest slot position of the group, with the expander modules to its right.*
- Empty slots are permitted between modules, with two exceptions:
 - A. There can be no empty slots to the left of a Bus Transmitter, analog, PCM, or ADS module.
 - B. If, in the future, modules will be placed in the empty slots and a Hand-held Monitor will be

GFK-0539C
August 1997

Remote I/O Scanner

used to reconfigure the remote drop, locate empty slots to the right in the rack. Otherwise, reconfiguration will change the I/O references assigned to the boards already there.

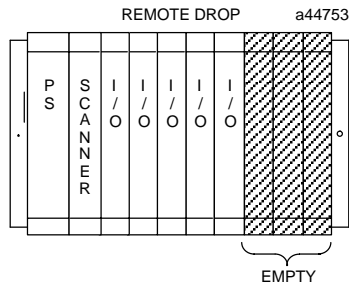

Remote I/O Scanner Installation

- Be sure the rack is powered-down.
- Grasp the module firmly and insert it into the card guide.
- Align the module's printed circuit board with the connector on the rack backplane. Slide it towards the connector until it begins to seat.
- Place one thumb on the left of the top plastic flange and the other thumb on the left of the bottom plastic flange. Push the board into the connector until the top and bottom latches click onto the rack rails.
- Be sure the module has seated properly.
- If the rack is in a high-vibration area, use screws to secure the module in the rack.

Remote I/O Scanner Removal

- Be sure the rack is powered-down.
- Grasp the module firmly at the top and bottom of the board cover with your thumbs on the front of the cover and your fingers on the plastic clips on the back of the cover.
- Squeeze the rack clips on the back of the cover with your fingers to disengage the clip from the rack rail and pull the board firmly to remove it from the backplane connector.
- Slide the printed circuit board along the card guide and remove it from the rack.

IC66* Bus Connections

For single (non-redundant) bus installations, the IC66* bus cable is connected to the upper four terminals of the Remote I/O Scanner (1 - 4 in the diagram). The lower eight terminals are not connected.

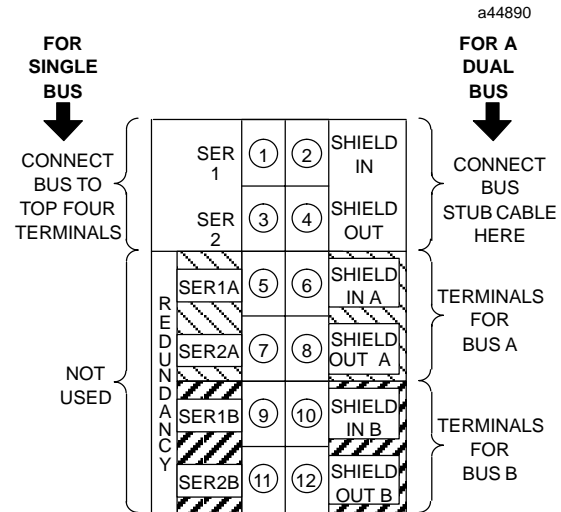

For dual (redundant) bus installations, the serial bus cable from the Bus Controller on bus A connects to the center four terminals on the terminal strip (5 - 8 in the diagram). The cable from the Bus Controller on Bus B connects to the lower four terminals (9 - 12). The Remote I/O Scanner contains an integral bus switching relay; there is no need to attach an external Bus Switching Module for dual bus configurations. If there is a bus stub from the Remote I/O Scanner to additional devices which are controlled by its bus switching action, it connects to the top four terminals (1 - 4); otherwise the top four terminals are unused.

The maximum exposed length of bare wires should be two inches. For added protection, each shield drain wire should be insulated with spaghetti tubing to prevent the Shield In and Shield Out wires from touching each other or the signal wires.

On a bus, connect Serial 1 to the Serial 1 terminals of the previous device and the next device. Connect Serial 2 to the Serial 2 terminals of the previous device and the next device. Connect the Remote I/O Scanner's Shield In terminal to Shield Out of the preceding device. Connect Shield Out to Shield In of the next device. If the Remote I/O Scanner is the first de-

Remote I/O Scanner

GFK-0539C
August 1997

vice on a bus, Shield In can be left unconnected. If it is the last device on a bus, Shield Out can be left unconnected. Note that the IC66* bus connections for a Remote I/O Scanner are not the same as the connections for an IC697 bus controller, even though the terminals are physically identical.

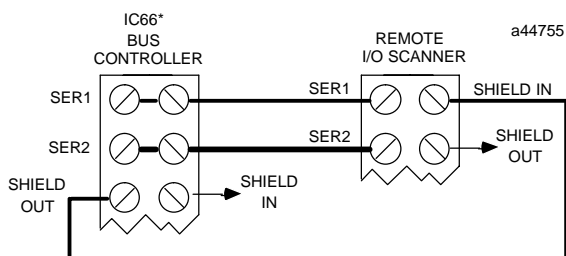

IC66* Bus Termination

If the Remote I/O Scanner is at either end of a bus (electrically), connect the appropriate terminating resistor across the Serial 1 and Serial 2 terminals. Impedance for the IC66* bus will be 75, 100, 120, or 150 ohms. Chapter 2 of the *I/O System User's Manual* (for IC660*) lists the correct impedance to use for each approved type of bus cable.

In a redundant bus application, if either cable of the dual bus ends at the Remote I/O Scanner, it must have its own terminating resistor. The upper four connectors are *never* terminated in a dual bus configuration.

Note

If the Remote I/O Scanner will be powered up when not connected to a properly-terminated bus, connect a 75-ohm resistor across its Serial 1 and Serial 2 terminals to assure proper powerup.

Serial Port Connections

The Remote I/O Scanner's serial port can be used for connection to a multidrop communications network or for direct connection of a programmer running the serial version of IC641 Programming Software.

Serial Port Termination

If the Remote I/O Scanner will be **at the end** of a communications network, or if a programmer will be con-

nected directly to it, the serial port must be terminated by connecting a 220 ohm resistor across pins 10 and 11 and another 220 ohm resistor across pins 8 and 15. These connections must be made inside the connector's D-shell. At the other end of the cable, terminate the SD and RTD pins in the same way.

Direct Programmer Connections

If the programmer is equipped with the parallel version of MS-DOS programming software and a Workstation Interface board, connection is made to a Bus Transmitter module in rack 0.

If the programmer is equipped with the serial version of MS-DOS programming software and a Workstation Interface board, connection is made to the serial port on the Remote I/O Scanner module.

If the programmer does not have a Workstation Interface board, connection must be made via an intermediate RS422/RS485 to RS232 converter.

If the serial port is needed for connection to a multi-drop communications network, an intermediate connector can be used. See the *Remote I/O Scanner User's Manual* for details.

Programmer Grounding

For proper operation, the programmer must have a ground connection in common with remote drop rack 0. Normally, the common ground connection is provided by connecting the programmer's power cord to the same power source (with the same ground reference point) as the rack. If a common ground cannot be established, use the RS-422 Isolated Repeater/RS-232 Converter IC655CCM590, or an equivalent product to protect the equipment.

Configuration

A Remote I/O Scanner must be configured to:

- Assign its Device Number (serial bus address).
- Assign its baud rate.
- Specify starting references and lengths for discrete inputs and outputs, and for analog inputs and outputs.
- Specify the Remote Drop ID.

GFK-0539C
August 1997

Remote I/O Scanner

Configuration can be done with:

- MS-DOS programming software release 3.0 or later. This software provides full configuration of I/O modules and allows selection of module options.
- **An IC66* Hand-held Monitor**, version 4.0 or later. The HHM automatically assigns I/O references to the modules in the remote drop. *The I/O modules in the remote drop operate in default mode if a Hand-held Monitor is used to enter or change configuration.* If the remote drop includes any analog expanders, a Hand-held Monitor cannot be used for configuration.

IC697 PLC Configuration

If the system host is an IC697 PLC, each Remote I/O Scanner must be added to the PLC configuration. With MS-DOS programming software release 3.0 or later, a separate program folder should be created for each remote drop. The folders should be organized so that the remote drop folders are located in the central PLC folder. The *Remote I/O Scanner User's Manual* gives complete configuration instructions.

Specifications †

Module Type	IC697RemoteI/OScannedIC697BEM733/735
LEDs	Module OK, I/O Enabled, Bus B Active
Size	Occupies single slot in IC697 remote rack
Ports	One 15-pin RS-422/485 compatible serial port, one 9-pin IC66* Hand-held Monitor port.
Current Required from +5V Bus	0.8 amps
Bus Type	Daisy-chained bus cable; single twisted pair plus shield or Twinax. Fiber optics cable and modems can also be used.
Bus Termination	75, 100, 120, or 150 ohm resistor at both ends of electrical bus cable.
Baud Rate	Configurable. 153.6 Kbaud standard, 153.6 Kbaud extended, 76.8 Kbaud, or 38.4 Kbaud.
Maximum Bus Length	7500 feet (2275 meters) at 38.4 Kbaud, 4500 feet (1365 meters) at 76.8 Kbaud, 3500 feet (1060 meters) at 153.6 Kbaud extended, 2000 feet (605 meters) at 153.6 Kbaud, standard. Maximum length at each baud rate also depends on cable type. The <i>IC66* I/O System User's Manual</i> provides a complete list of cable types, showing corresponding bus lengths and baud rates.
Maximum Number of Devices per Bus	32 devices at 153.6 Kbaud standard, 153.6 Kbaud extended, or 76.8 Kbaud. 16 devices at 38.4 Kbaud. Includes bus controller and Hand-held Monitor.
Maximum Number of Remote Drops per Bus	Depends on baud rate as follows:
153.6Kbaud extended	Up to 20 fully-loaded drops, or up to 30 drops if not fully-loaded.
153.6Kbaud standard	Up to 20 fully-loaded drops, or up to 30 drops if not fully-loaded.
76.8Kbaud	Up to 10 fully-loaded drops, or up to 30 drops if not fully-loaded.

† Refer to GFK-0867B, or later for product standards and general specifications. For installations requiring compliance to more stringent requirements (for example, FCC or European Union Directives), refer to *Installation Requirements for Conformance to Standards*.

Note: For Conformal Coat option, or Low Temperature Testing option please consult the factory for price and availability.

For More Information,

- Please refer to these related publications:
- Remote I/O Scanner Module User's Manual.*
 - Programmable Controller Installation Manual.*
 - Programming Software User's Manual.*
 - Programmable Controller Reference Manual.*