

# Special Applications Modules

IC697HSC700

GFK-1057D  
August 1997

## High Speed Counter

### Features

- Single slot module
- Five selectable counter types
- 12 single-ended or differential inputs
- TTL, Non-TTL and Magnetic Pickup input thresholds
- Four positive logic (source) outputs with LED indicators
- External oscillator
- Built-in +5 VDC output
- Software configuration
- Internal module diagnostics
- Module OK and Output State LEDs
- Removable terminal strip for field wiring connections

Configuration is done using the configuration function of the MS-DOS® or Windows® programming software running on Windows® 95 or Windows NT® over Ethernet TCP/IP or through the SNP port. The Programming Software configuration function is installed on the programming device. The programming device can be an IBM® XT, AT, PS/2® or compatible Personal Computer.

### Functions

The IC697 High Speed Counter (HSC) module, catalog number IC697HSC700, directly processes rapid pulse signals up to 200 KHz (800 KHz for Type E in A Quad B mode). The module is able to sense inputs, process input count data, and control its outputs without communicating with the PLC CPU. The HSC has a simple and user-friendly PLC interface that makes it extremely useful in industrial applications such as:

- Turbine flowmeter
- Meter proving
- Velocity measurement
- Material handling
- Motion control
- Process control

® IBM and PS/2 are registered trademarks of International Business Machines Corporation.

® MS-DOS, Windows, Windows 95, and Windows NT are registered trademarks of Microsoft Corporation.

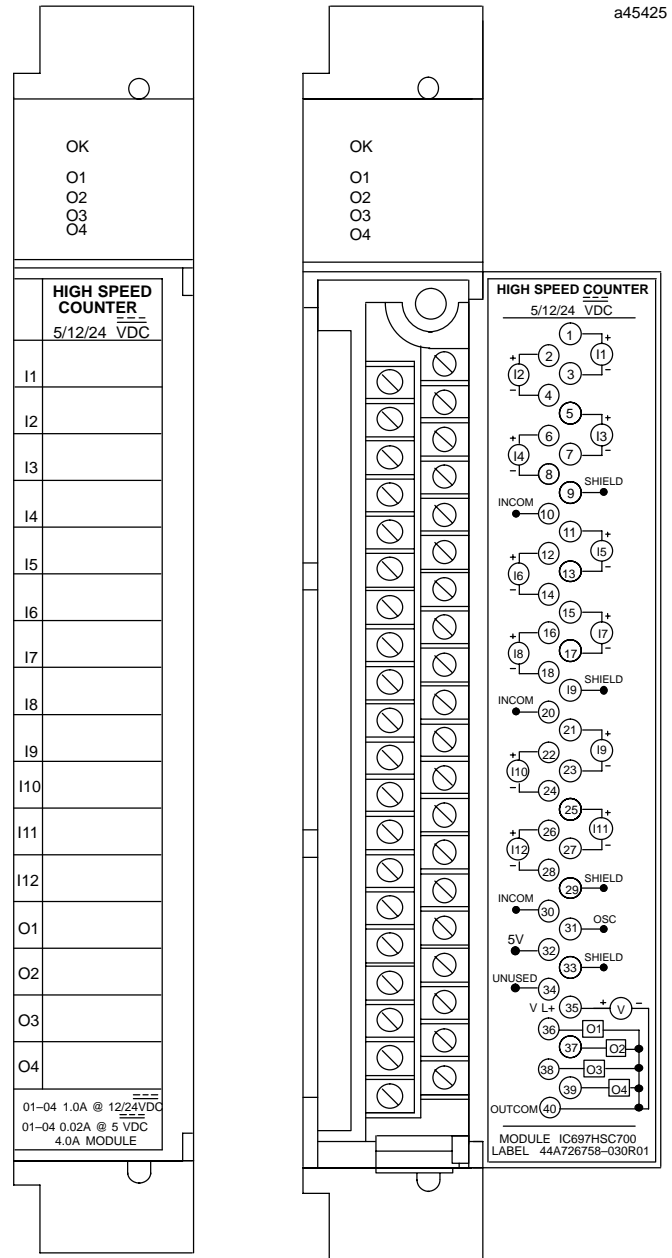

a45425

GFK-1057D  
August 1997

## High Speed Counter

### Product Compatibility Requirements

| Product                      | Version                                       |
|------------------------------|---|
| IC697 CPU                    | 5.50 or later (CPU models 781, 782, 914, 924) |
| MS-DOS Programming Software  | 5.0x or later                                 |
| Windows Programming Software | 1.0 or later                                  |

### High Speed Counter Types

The High Speed Counter can be configured as one of five types: A, B, C, D, or E. All counters have 12 inputs, four preset outputs, and optional PLC ladder interrupt capability.

#### Type A

In Type A configuration, the HSC has four identical and independently programmable unidirectional 16-bit counters, which can be configured for up or down operation. Each counter has three inputs: Preload, Count Pulse and Strobe.

#### Type B

In Type B configuration, the HSC has two identical and programmable bi-directional 32-bit counters. Each counter can be independently configured to operate in Up/Down, Pulse/Direction or A Quad B mode. Both counters have two independent Strobe inputs and Strobe registers. Each counter has a single Preload input to set the accumulator and a Disable input to suspend counting.

This counter type can be configured to link strobes. In this mode, a count on the Counter 2 inputs will strobe both Counter 1 and Counter 2 Accumulator values into their respective Strobe 1 registers. This feature can be used to accurately measure a pulse rate against a reference pulse or to compare two different pulse rates.

#### Type C

In Type C configuration, the HSC has one differential bi-directional 32-bit counter with a Disable input to suspend counting. It also provides a Home cycle to initialize the accumulator to a pre-defined Home Position. A Home Switch input and a Marker input are used to indicate the Home Position to each counter input. The configured Home value specifies the accumulator value at the Home Position.

Two sets of bi-directional counter inputs can be connected differentially. Each pair of inputs can be configured for Up/Down, Pulse/Direction or A Quad B mode. The Type C configuration has three Strobe registers with Strobe inputs and two Preload values with Preload inputs.

#### Type D

In Type D configuration, the HSC has four bi-directional 32-bit counters that can be configured to count in Up/Down, Pulse/Direction, A Quad B x1, A Quad B x2, or A Quad B x4 mode. Each counter has a marker input which can be used to set its accumulator value to the counter's Home Position value. When configured in A Quad B mode, the High Speed Counter detects and reports quadrature errors.

#### Type E

The Type E counter contains two identical 16-bit counters with Strobe and Preload inputs capable of counting Up/Down or A Quad B signals. Each has a Count Disable and a Strobe Disable input. The Type E counter is designed primarily as a Down counter, but can handle up counts to account for A Quad B jitter. When a counter counts down to zero, it turns on a dedicated preset output with a 5 $\mu$ s response.

### Type A, B, C, and D Operating Features

Operating features of the High Speed Counter for Types A, B, C, and D are described below. Features that have selectable parameters are configured using the MS-DOS or Windows programming software configurator function that has been installed on your programming computer. For detailed information about selectable features, refer to the *High Speed Counter User's Manual*, GFK-1062.

#### Count Rate

Maximum count rates are 200 KHz with the high frequency filter and 30 Hz with the low-frequency filter.

#### Selectable Input Filters

The Count, Count Disable, and Preload inputs for each counter can be configured for a high frequency filter (2.5 microseconds) or a low-frequency filter (12.5 milliseconds).

## High Speed Counter

GFK-1057D  
August 1997

### Continuous or Single-Shot counting

Each counter can be configured to operate in either continuous or single-shot mode.

*Continuous Counter Mode:* If either the upper or lower count limit is exceeded the counter wraps around to the other limit and continues.

*Single-shot Counter Mode:* The counter counts to either the upper or lower limit and stops. When the counter is at the limit, counts in the opposite direction back it off from the limit.

### Counter Accumulator

The Accumulator contains the current count value of each counter. The CPU can read the accumulator value or set it from the application program.

### Counts per Timebase Register

Each counter stores the number of counts that have occurred in a specified period of time. A timebase value from 1 ms to 65535 ms can be configured.

### Strobe Register

Type A, B and C counters have one or more Strobe registers that capture the current Accumulator value when a Strobe input transitions. The Strobe inputs are edge-triggered and can be configured for positive-edge or negative-edge response. The Strobe registers can be configured to update at any Strobe trigger or only on the first strobe trigger

### Preloads

Counters A, B and C have one or more Preload inputs. The Preload inputs set the accumulator to a configured Preload value. %Q bits sent from the PLC can also be used to generate Preload and set the accumulator to the configured Preload value.

### Selectable On/Off Output Presets

Counter output signals can be configured to be On or Off when the count Accumulator reaches configured

On and Off Preset values. There are four On/Off Preset outputs which can be independently assigned to any counter. An assigned output's state indicates when the counter Accumulator is between the defined On and Off points. Output polarity can be configured to On only between points or Off only between points by the relative location of the On/Off Presets.

### Selectable Preset Interrupts

Each Preset output can generate PLC interrupts from On and/or Off transitions. Interrupts can be enabled for either or both transitions of each Preset output.

### Oscillator

The module provides an external oscillator output that can be wired as a count input to any counter and used as a timing reference for measurement. The 5V square wave oscillator output can be configured to operate at frequencies from 15 Hz to 1 MHz. This output has a CMOS buffer with a 47 ohm output impedance.

### Data Commands

The PLC can send data commands to the HSC through %AQ data or with a COMMREQ. These commands allow the user to dynamically modify counter operation and configuration parameters. Configuration parameters that can be dynamically modified include: accumulator value, counter limits, Preload values, On and Off Preset values and Home Position.

### Velocity Command

A %AQ or COMMREQ Data Command can be used to generate an internal velocity of up to 100,000 counts per second. The counter accumulator will increment or decrement at the commanded velocity. Counts generated by the user count inputs will be accumulated in addition to the Velocity Command counts.

### Accumulator Adjust

A data command can be used to adjust the accumulator value from -128 to +127 counts at any time.

GFK-1057D  
August 1997

## High Speed Counter

### Type E Operating Features

Operating features of the High Speed Counter for Type E are described below.

#### Count Rate and Input Filters

The maximum count rate with the low-frequency filter (12.5 milliseconds) is 30 Hz; with the high-frequency filter (2.5 $\mu$ s), the maximums are 200 KHz in Up/Down mode and 800 kHz in A Quad B mode. The Count, Count Disable, and Preload inputs for each counter can use either filter, but the Strobe and Strobe Disable inputs use only the high-frequency filter.

#### Continuous or Single-Shot Counting

Each counter can be configured to operate in either continuous or single-shot mode.

*Continuous Counter Mode:* When the counter decrements to zero, it turns on the fast response output and automatically preloads itself to the preload value and continues counting.

*Single-shot Counter Mode:* When the counter counts to zero, it turns on the fast response output and ignores count pulses until a preload occurs.

#### Preloads

A rising edge on the Preload input, a rising edge on the %Q Preload Accumulator bit, or the counter decrementing to zero in Continuous mode will set the accumulator to a configured Preload value. Preloads caused by the Preload input and count decrementing to zero will set a %I bit in the PLC to indicate a preload occurred.

#### Strobe Register Stack

Each counter has a Strobe Register stack which will store up to four strobe values. Strobes can be configured to occur on rising, falling, or both edges of the Strobe input. %I bits indicate how many strobes have occurred. A Reset Strobes %Q bit or a Preload clears the Strobe Register stack and %I indicators. A Strobe Disable input causes all Strobe input transitions to be ignored.

### Counter Outputs

The Type E counter supports two types of output presets, Fast Response and Standard.

**Fast Response:** There is one dedicated fast response output for each accumulator. The fast response output turns on within 15 $\mu$ s of the associated counter decrementing to zero, with less than 2 $\mu$ s variation. In addition, two output modes are supported for the fast response outputs.

*Pulse Output Mode:* The output turns on when the Accumulator counts down to zero and stays on for a configured duration, from 1 to 1000 milliseconds.

*Latched Output Mode:* (Single Shot mode only) The output turns on when the Accumulator counts down to zero and stays on until a Preload occurs.

**Standard Output Presets:** Outputs 3 and 4 can be assigned to either counter and configured to be On or Off when the count Accumulator reaches configured On and Off values. An assigned output's state indicates when the counter Accumulator is between the defined On and Off points.

#### Output Interrupts

Interrupts can be enabled or disabled for Off to On transitions of the fast response outputs. Interrupts can be enabled or disabled for either transition of the standard preset outputs.

#### Oscillator

The module provides an external oscillator output that can be wired as a count input to any counter and used as a timing reference for measurement. The 5V square wave oscillator output can be configured to operate at frequencies from 15 Hz to 1 MHz. This output has a CMOS buffer with a 47 ohm output impedance.

#### Data Commands

The PLC can send data commands to the HSC through %AQ data or with a COMMREQ. These commands allow the user to dynamically modify counter operation and configuration parameters. Configuration parameters that can be dynamically modified include: Preload values, On and Off Preset values, and Fast Response output duration.

High Speed Counter

GFK-1057D  
August 1997

Location in a System

A High Speed Counter module can be installed in any I/O slot in the CPU rack or in any I/O slot in an expansion rack in a system. For interrupts to work, there can be no empty slots

between the CPU and the HSC. The following figure shows two typical installations: (A) a High Speed Counter installed in the CPU rack in a single rack installation and (B), multiple High Speed Counter modules installed in an expansion rack in a multiple rack system.

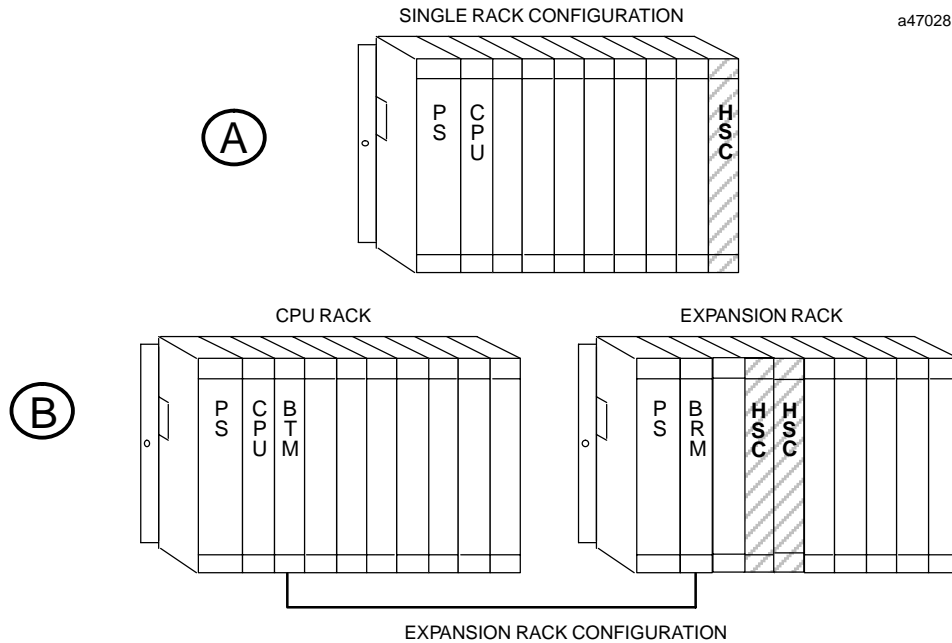

Figure 1. Example of High Speed Counter Module Installation Configurations

Installing a High Speed Counter

For detailed instructions on how to install a High Speed Counter module, refer to *Installation Procedures* in the applicable *Programmable Controller Installation Manual*. Also refer to the *High Speed Counter User's Manual*. Following is a basic description of the module (refer to Figure 2 for location of hardware features).

Status Indication

Five status LEDs are viewable on the module as shown in Figure 2. The function of each LED is as follows:

MODULE OK LED

The MODULE OK LED indicates current status of the High Speed Counter module as described in Table 1.

Table 1. MODULE OK LED Status

| State    | Description  |
|----------|--|
| OFF      | When the MODULE OK LED is off, the High Speed Counter module is <i>not</i> functioning. This is the result of a hardware malfunction; for example, the diagnostic checks detected a failure, or the PLC CPU is <i>not</i> present. Corrective action is required in order to get the module functioning again. |
| ON       | When the LED is on steadily, the High Speed Counter module is functioning properly. Normally, this LED should <i>always</i> be on, indicating that the diagnostic tests were successfully completed and the programming software configuration data for the module is correct.                                 |
| Flashing | The LED flashes at a 1 Hz rate when power-up diagnostics have completed successfully and the module is waiting for configuration. It also flashes at a 4 Hz rate when an error occurs. When the error is cleared, the LED will return to being on steadily.  |

GFK-1057D  
August 1997

High Speed Counter

Output LEDs (O1 - O4)

These four LEDs indicate the ON/OFF state of the corresponding module output circuit. The output circuits can be used to drive indicating lights, solenoids, relays, and other such similar devices. The LEDs are either ON or OFF (output activated or not activated).

User Terminal Connector

The removable terminal strip has 40 screw terminals for connection to field devices to the High Speed Counter inputs and outputs. Pin assignments for field wiring connections are provided in the following table. For detailed information on how each signal applies to the different counter types, refer to the *High Speed Counter User's Manual*.

Table 2. User Terminal Connector Pin Assignments

| Pin Number | Signal Name | Pin Number | Signal Name |
|------------|-------------|------------|-------------|
| 1          | IN1P        | 21         | IN9P        |
| 2          | IN2P        | 22         | IN10P       |
| 3          | IN1M        | 23         | IN9M        |
| 4          | IN2M        | 24         | IN10M       |
| 5          | IN3P        | 25         | IN11P       |
| 6          | IN4P        | 26         | IN12P       |
| 7          | IN3M        | 27         | IN11M       |
| 8          | IN4M        | 28         | IN12M       |
| 9          | SHIELD      | 29         | SHIELD      |
| 10         | INCOM       | 30         | INCOM       |
| 11         | IN5P        | 31         | OSC         |
| 12         | IN6P        | 32         | 5VP         |
| 13         | IN5M        | 33         | SHIELD      |
| 14         | IN6M        | 34         | not used    |
| 15         | IN7P        | 35         | OUTPWR      |
| 16         | IN8P        | 36         | OUT1        |
| 17         | IN7M        | 37         | OUT2        |
| 18         | IN8M        | 38         | OUT3        |
| 19         | SHIELD      | 39         | OUT4        |
| 20         | INCOM       | 40         | OUTCOM      |

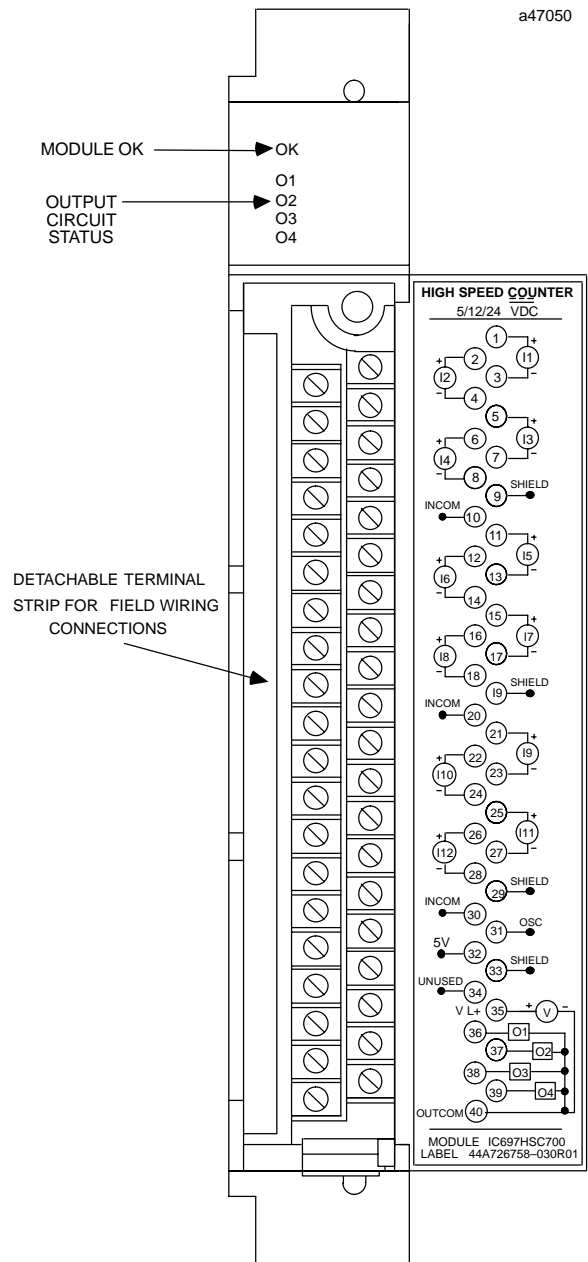

Figure 2. High Speed Counter Module - User Features

High Speed Counter

GFK-1057D  
August 1997

Recommended Field Wiring Procedures

The following procedures are recommended when connecting field wiring to the detachable terminal board on the High

Speed Counter module. Module features referenced in the following procedures which are common to most IC697 I/O modules are illustrated in the following figure.

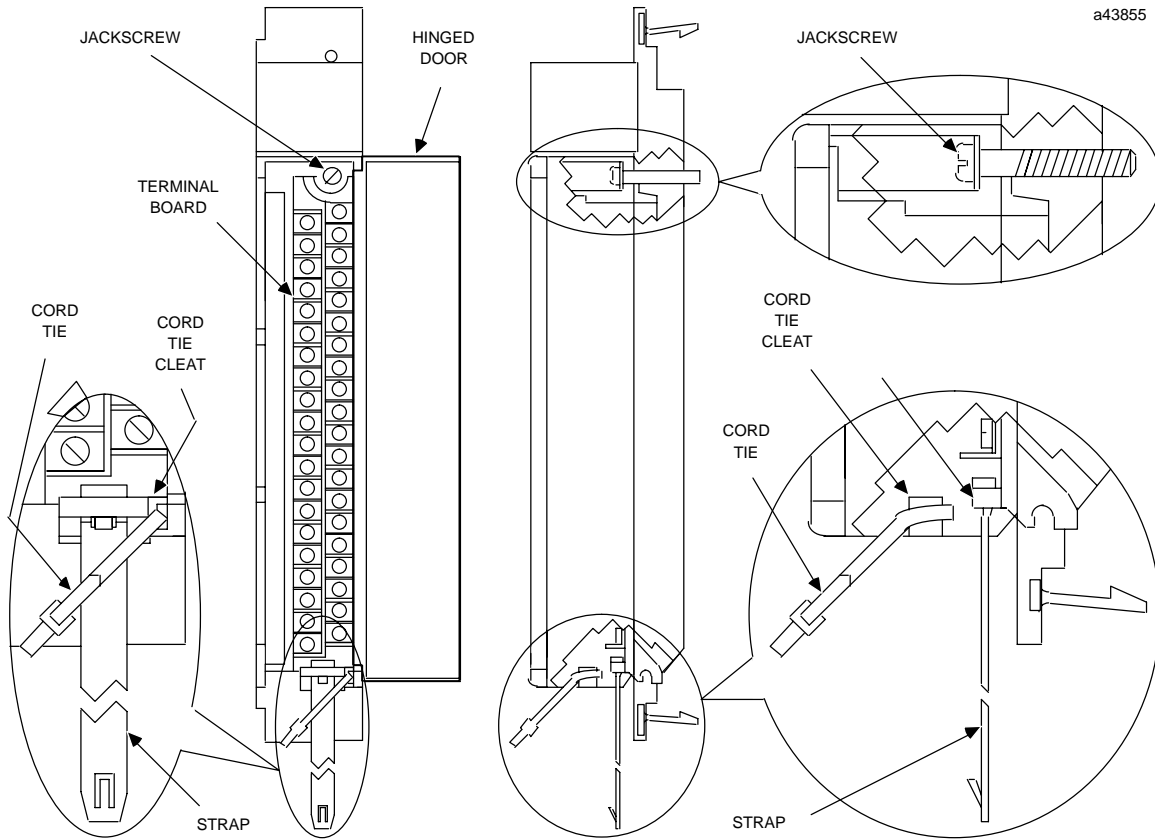

Figure 3. I/O Module Features

1. Turn off power before removing or installing terminal boards. Open the hinged door on the module to access a jackscrew which holds the terminal board securely in place. The detachable field wiring terminal board can now be removed from the module by turning the jackscrew counter-clockwise until it is fully disengaged.
2. To remove the terminal board, grasp the top of the terminal board and swing it outward.
3. The terminal board is designed to accept wire sizes from AWG #22 (0.36 mm<sup>2</sup>) through AWG #14 (2.1 mm<sup>2</sup>). It is important that when using AWG #14 (2.1 mm<sup>2</sup>) wire for wiring all points, that a maximum insulation diameter of .135 inch (3.43mm) not be exceeded. To ensure proper connection, two wires may be terminated on any one terminal only if both wires are the same size.
4. The terminal board is designed to accept a maximum of (40) AWG #14 (2.1 mm<sup>2</sup>)wires. If AWG #14 (2.1 mm<sup>2</sup>) wires are to be used, then wire markers should be placed at least 8 inches (203 mm) from termination end to provide sufficient space for the hinged door to close.

**Caution**

**Do not use the hinged door to remove the terminal board. The hinged door could be damaged if this is done.**

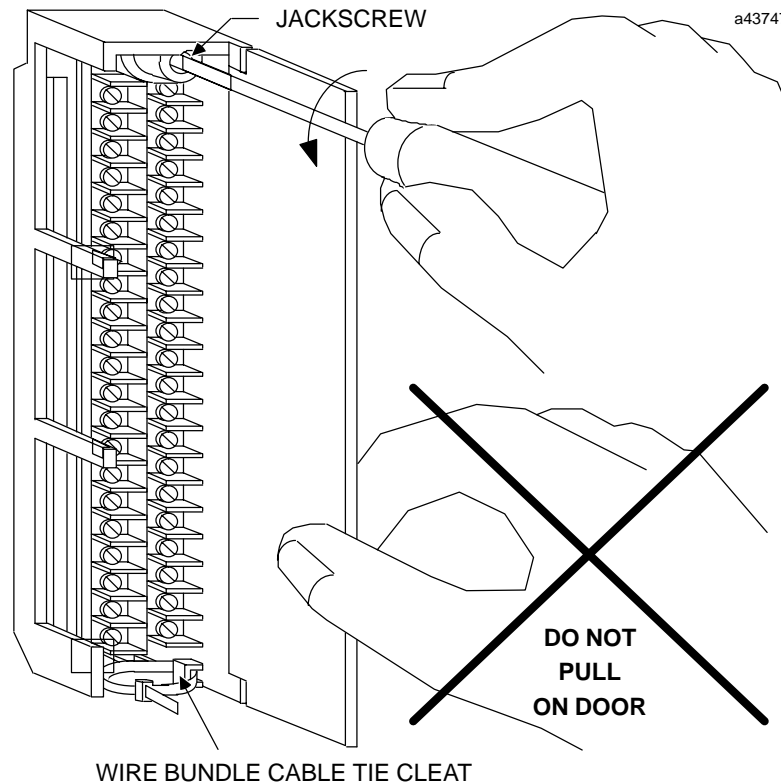

Figure 4. Removal of I/O Terminal Board

5. After completing connections to all modules in a rack, the wire bundle must be secured. To ensure that the wire bundle is secured properly, it is recommended that a cable tie be wrapped around the wire bundle and tightly secured through the cable tie cleat located at the lower right corner of the terminal board. For extremely large wire bundles, additional cable ties should be used.
6. A door label insert is included with each module to indicate circuit wiring information and provide space to record user circuit wiring identification. A slot is provided on the hinged door to allow for insertion of this label. If the label is difficult to insert, crease the scored edge before insertion. The outside label has a color coded stripe to allow quick identification of the module voltage type (blue: low voltage; red: high voltage).
7. After field wiring is completed, the terminal board should be securely fastened to the rack by inserting the terminal board strap (attached to each module) into the small rectangular slots in the bottom card guide grill on the rack. This strap not

only secures the terminal board to the rack, it also provides a way of identifying the wired terminal board with its correct mating rack slot location.

8. For adequate module ventilation, it is recommended that at least a 6 inch (152mm) clearance be allowed above and below the rack grill. Wire bundles should not obstruct the rack grill work.

### Removing an I/O Module

The instructions below should be followed when removing an I/O module from its slot in a rack.

- Grasp the board firmly at the top and bottom of the board cover with your thumbs on the front of the cover and your fingers on the plastic clips on the back of the cover.
- Squeeze the rack clips on the back of the cover with your fingers to disengage the clip from the rack rail and pull the board firmly to remove it from the backplane connector.
- Slide the board along the card guide and remove it from the rack.



Table 3. Specifications for IC697HSC700 †

|   |  |                        |                |                        |      |      |        |      |      |        |
|---|--|------------------------|----------------|------------------------|------|------|--------|------|------|--------|
| <p><b>General:</b></p> <p><b>Module Operating Voltage</b></p> <p><b>Module Current Drain</b></p> <p><b>Maximum Count Rate</b><br/>Types A - D, and Type E in Up/Down mode<br/>Type E in A Quad B mode</p> <p><b>Output Points</b></p> <p><b>LEDs</b></p> <p><b>Input and Output Isolation</b><br/>Peak (1 second)<br/>Steady Status</p>   | <p>5 VDC (from backplane)</p> <p>1A + (10 mA x number of ON outputs) + (1.6 x encoder current)</p> <p>200 KHz<br/>800 KHz</p> <p>Powered by user supplied 5V, or 10 to 30 VDC</p> <p>MODULE OK and O1 - O4 (Output circuit. status)</p> <p>1500volts<br/>30 V AC/DC</p>  |                        |                |                        |      |      |        |      |      |        |
| <p><b>Inputs</b></p> <p><b>Voltage Range</b></p> <p>TTL</p> <p>Non-TTL</p> <p><b>Magnetic Pickup (I1 to I4 only)</b></p> <p><b>Input Thresholds (I1 to I12)</b></p> <p>V<sub>on</sub></p> <p>V<sub>off</sub></p> <p><b>Encoder Power</b></p> <p><b>Input Filter Delay</b></p> <p>IN1 to IN8</p> <p>IN9 to IN12</p> <p><b>Input Impedance</b></p> <p><b>Input Hysteresis</b></p> <p><b>Input Cable</b></p> | <p>5 VDC</p> <p>10 to 30 VDC</p> <p>400 mV</p> <table border="0"> <tr> <td><i>TTL</i></td> <td><i>Non-TTL</i></td> <td><i>Magnetic Pickup</i></td> </tr> <tr> <td>1.4V</td> <td>8.0V</td> <td>400 mV</td> </tr> <tr> <td>0.8V</td> <td>5.0V</td> <td>200 mV</td> </tr> </table> <p>5 VDC, 500 mA @40°C (104°F), 300 mA @60°C (140°F)</p> <p>10 ms or 2 µs selectable</p> <p>2 µs</p> <p>6000 ohms</p> <p>250 mV typical</p> <p>Shielded cable recommended<br/>Maximum length: 30 meters (100 feet)</p> | <i>TTL</i>             | <i>Non-TTL</i> | <i>Magnetic Pickup</i> | 1.4V | 8.0V | 400 mV | 0.8V | 5.0V | 200 mV |
| <i>TTL</i>  | <i>Non-TTL</i>   | <i>Magnetic Pickup</i> |                |                        |      |      |        |      |      |        |
| 1.4V  | 8.0V   | 400 mV                 |                |                        |      |      |        |      |      |        |
| 0.8V  | 5.0V   | 200 mV                 |                |                        |      |      |        |      |      |        |
| <p><b>Outputs</b></p> <p><b>Output Type</b></p> <p><b>Maximum Supply Voltage</b></p> <p><b>Maximum Output Current at 60°C (140°F)</b></p> <p><b>Output Current using 5 VDC supply</b></p> <p><b>Inductive Load Clamp Voltage</b></p> <p><b>OFF State Leakage Current</b></p>  | <p>Positive Logic, optically isolated</p> <p>30.0 VDC</p> <p>1.0 A for each output using 10 to 30 VDC supply</p> <p>20 mA typical</p> <p>-8.0 V typical</p> <p>10 µA for each output</p>   |                        |                |                        |      |      |        |      |      |        |

Table 3. Specifications for IC697HSC700 (continued)

|   |   |
|---|---|
| <b>Output Response Time</b><br>Type A - D, Type E Slow Response | 300 $\mu$ s typical<br>650 $\mu$ s worst case   |
| <b>Type E Fast Response</b>                                     | 24 Volts    On: 7 $\mu$ s typical<br>10 $\mu$ s worst case<br>Off: 56 $\mu$ s typical<br><br>5 Volts     On: 10 $\mu$ s typical<br>15 $\mu$ s worst case<br>Off: 63 $\mu$ s typical |
| <b>Output Response Variation</b><br>Slow Response               | 650 $\mu$ s worst case  |
| Fast Response   | 1 $\mu$ s worst case  |
| <b>Output Protection</b>  | 5.0 A fuse (5x20mm replaceable) common to all outputs   |
| <b>VME</b>  | System designed to support the VME standard C.1   |

† Refer to GFK-0867B, or later for product standards and general specifications. For installations requiring compliance to more stringent requirements (for example, FCC or European Union Directives), refer to *Installation Requirements for Conformance to Standards*.

Table 4. Ordering Information

| Description              | Catalog Number |
|--------------------------|----------------|
| HighSpeed Counter Module | IC697HSC700    |

Note: For Conformal Coat option, or Low Temperature Testing option please consult the factory for price and availability.