

Operation of the 120 VOLT AC16 Point Input Module

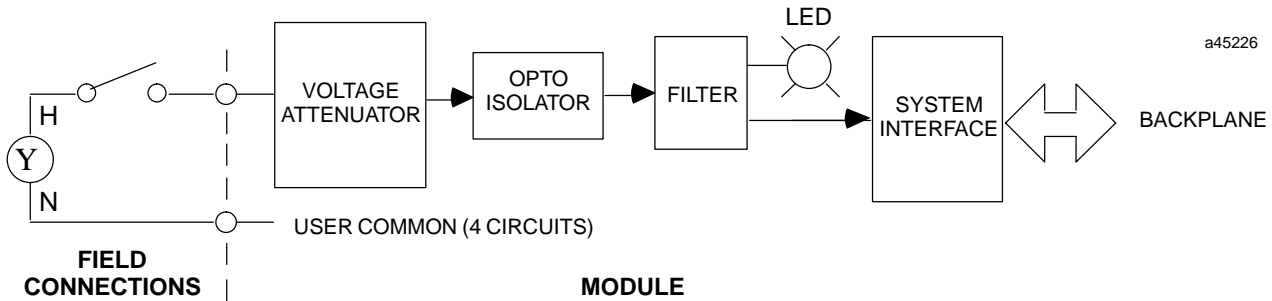

Figure 1. Block Diagram for IC697MDL251

Input Characteristics

The 120 Volt AC 16 Point Input Module is compatible with a wide variety of input devices, such as:

- Pushbuttons, limit switches, selector switches
- Electronic proximity switches, both 2-wire and 3-wire

The input circuitry is capacitive to give low heat dissipation and associated high reliability and long life.

Input current characteristics provide 10mA typically in the ON state, and can sink up to 2.2mA of leakage current in the OFF state to the input device.

This module is compatible with a wide range of both 2-wire and 3-wire proximity switches. To determine compatibility with a specific proximity switch, find the ON state characteristics of the switch in the illustration below.

If that point falls to the left of the input load line, the ON state characteristics are compatible. As an example, the ON state requirements of a compatible proximity switch of 5mA at 20 volts drop is shown.

In addition, the OFF-state current must be less than 2.2mA.

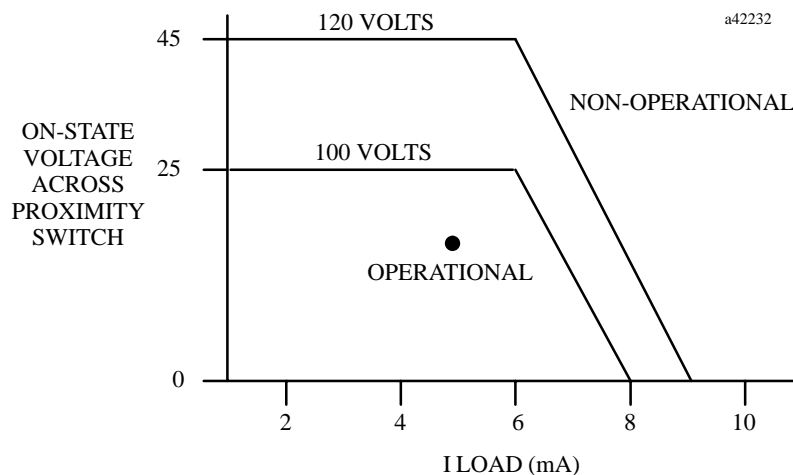

Figure 2. Proximity Switch Compatibility

120 Volt AC, 16-Point Input Module

GFK-0718C
August 1997

Module Power

The 120 Volt AC 16 Point Input Module requires 0.35 amps from the 5 volt bus on the backplane.

Module Mechanical Keying

This module includes a mechanical key that prevents inadvertent substitution of one module type for another in a given slot. The key fits a uniquely shaped area on the board below the connector. The key is included with each module.

When the module is first installed, the key latches onto the backplane center rail. When the module is extracted, the key remains in the center rail, configuring the slot to accept only identical module types.

If it is necessary to change the module location in the rack after the key has been latched onto the center rail of the rack, the key can be removed by pushing it upward to unhook the latch while pulling it off the rail. It may then be reinserted onto the module and the module inserted into the rack in the desired location. Note that only the power supply can be placed in the leftmost rack position.

Field Wiring

The module is wired as shown in the illustration on the right of this page. Since each group of four inputs is isolated from the others, a wire from the power source to the power input terminal for each group (terminal number 10, 20, 30, or 40) is required (power input terminals for each group are not connected inside the module).

The detachable field wiring terminal board will accept wire sizes from #22 (0.36 mm²) through #14 (2.10 mm²). Two wires may be terminated on a given lug if both wires are the same size. There is room for a bundle of forty #14 (2.10 mm²) wires to be routed out through the terminal board cavity.

The wire bundle can be secured to the terminal board by passing a cable tie through a cleat located at the lower corner of the terminal board.

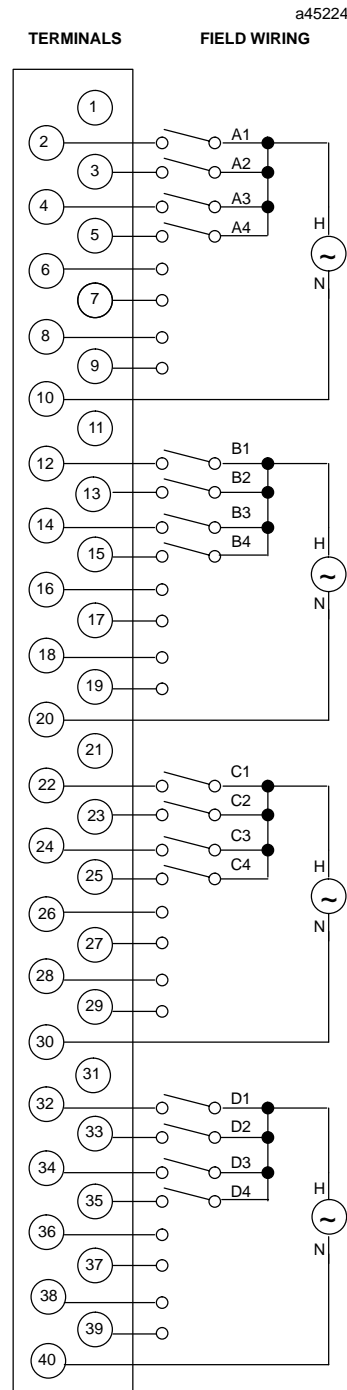

GFK-0718C
August 1997

120 Volt AC, 16-Point Input Module

Recommended Field Wiring Procedures

The following procedures are recommended when connecting field wiring to the detachable terminal board on this input

module. Module features referenced in the following procedures which are common to all I/O modules for the IC697 PLC are illustrated in the following figure.

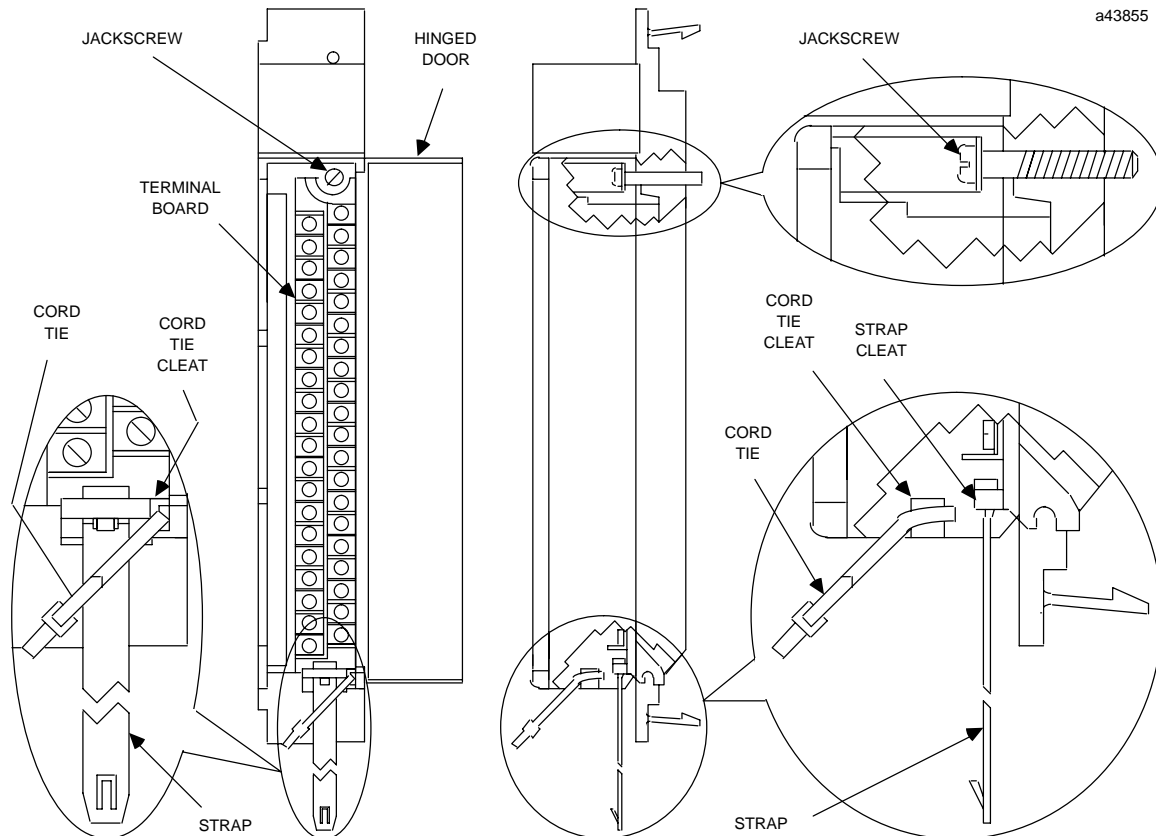

Figure 3. I/O Module Features

1. Turn off power before removing or installing terminal boards. Open the hinged door on the module to access a jackscrew which holds the terminal board securely in place. The Detachable field wiring terminal board can now be removed from the module by turning the jackscrew counter-clockwise until it is fully disengaged.
2. To remove the terminal board, grasp the top of the terminal board and swing it outward as shown in Figure 2.
3. The terminal board is designed to accept wire sizes from AWG #22 (0.36 mm^2) through AWG #14 (2.10 mm^2). It is important that when using AWG #14 (2.10 mm^2) wire for wiring all points, that a maximum insulation diameter of .135 inch (3.43 mm) not be exceeded. To ensure proper connection, two wires may be terminated on any one terminal only if both wires are the same size.
4. The terminal board is designed to accept a maximum of (40) AWG #14 (2.10 mm^2) wires. If AWG #14 (2.10 mm^2) wires are to be used, then wire markers should be placed at least 8 inches (203 mm) from termination end to provide sufficient space for the hinged door to close.

Caution

Do not use the hinged door to remove the terminal board. The hinged door could be damaged if this is done.

120 Volt AC, 16-Point Input Module

GFK-0718C
August 1997

Figure 4. Removal of I/O Terminal Board

5. After completing connections to all modules in a rack, the wire bundle must be secured. To ensure that the wire bundle is secured properly, it is recommended that a cable tie be wrapped around the wire bundle and tightly secured through the cable tie cleat located at the lower right corner of the terminal board. For extremely large wire bundles, additional cable ties should be used.
6. A door label insert is included with each module to indicate circuit wiring information and provide space to record user circuit wiring identification. A slot is provided on the hinged door to allow for insertion of this label. If the label is difficult to insert, crease the scored edge before insertion. The outside label has a color coded stripe to allow quick identification of the module voltage type (blue: low voltage; red: high voltage).
7. After field wiring is completed, the terminal board should be securely fastened to the rack by inserting the terminal board strap (attached to each module) into the small rectangular slots in the bottom card guide grill on the rack. This strap not

only secures the terminal board to the rack, it also provides a way of identifying the wired terminal board with its correct mating rack slot location.

8. For adequate module ventilation, it is recommended that at least a 6 inch (152 mm) clearance be allowed above and below the rack grill. Wire bundles should not obstruct the rack grill work.

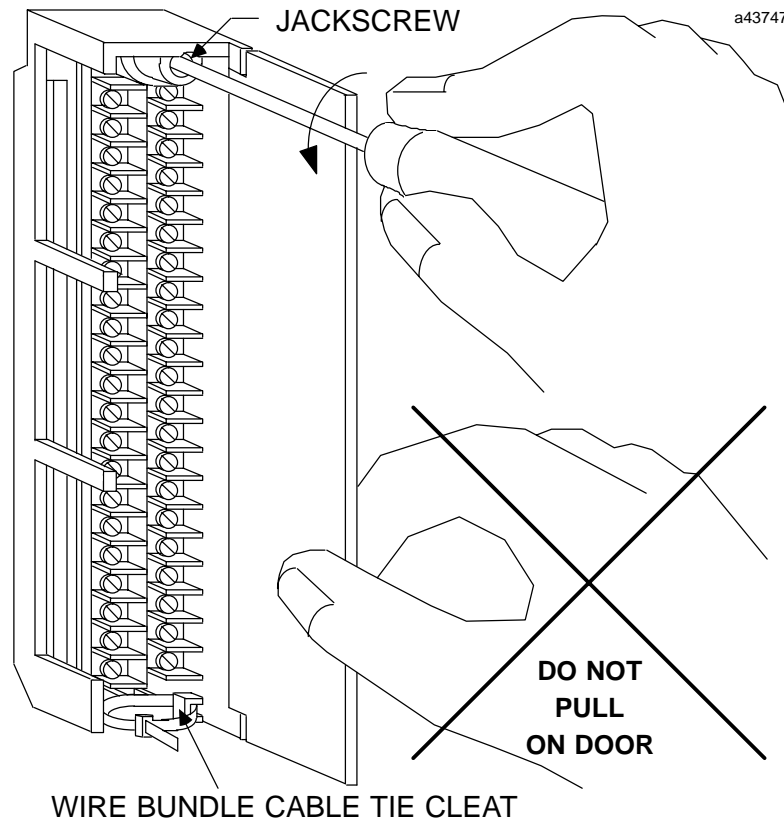
Removing an I/O Module

The instructions below should be followed when removing an I/O module from its slot in a rack.

- Grasp the board firmly at the top and bottom of the board cover with your thumbs on the front of the cover and your fingers on the plastic clips on the back of the cover.
- Squeeze the rack clips on the back of the cover with your fingers to disengage the clip from the rack rail and pull the board firmly to remove it from the backplane connector.
- Slide the board along the card guide and remove it from the rack.

GFK-0718C
August 1997

120 Volt AC, 16-Point Input Module

Table 1. Specifications for IC697MDL251 †

Rated Voltage:	120 VAC, 47 to 63 Hz Sinusoidal
Inputs per Module:	16 (four groups of four inputs each)
Isolation:	1500 volts RMS - any input to backplane 500 volts RMS between input groups
Input Current:	10mA (typical) at rated voltage (reactive)
Input Characteristics -	
On-state Voltage:	75 to 132 volts AC, 47 to 63 Hz Sinusoidal
Off-state Voltage:	0 to 25 volts AC, 47 to 63 Hz Sinusoidal
On-state Current:	6mA to 15mA
Off-state Current:	0 to 3mA (2.2 minimum at 25V input)
Filter Delay Time:	20mstypical
Current Required from 5VDC backplane bus:	0.35 amps
VME	System designed to support the VME standard C.1

† Refer to GFK-0867B, or later for product standards and general specifications. For installations requiring compliance to more stringent requirements (for example, FCC or European Union Directives), refer to *Installation Requirements for Conformance to Standards*.

Table 2. Ordering Information

Description	Catalog Number
Input Module: 120 Volt AC, 16 Points	IC697MDL251

Note: For Conformal Coat option, or Low Temperature Testing option please consult the factory for price and availability.