

# Discrete Input Modules

IC697MDL654

GFK-0380G  
August 1997

## 48 Volt DC Positive/Negative Logic, 32-Point Input Module

### Features

- 32 Points - Four isolated groups of 8 points each
- Positive/Negative Logic Compatibility
- Proximity switch compatible
- Input filter selectable\* - 1 ms or 10 ms
- One input configurable as interrupt\*

\* These features are available for all IC697 Programmable Logic Controllers (PLC). They may not be available when this module is used with other types of PLCs. See the applicable *Programmable Controller Reference Manual* for details.

### Functions

The 48 Volt DC Pos/Neg Input Module provides 32 input points in four isolated groups of eight points each. The input current-voltage characteristics meet IEC standard (type 1) specifications.

LED indicators which give the ON-OFF status of each point on the logic (PLC) side of the circuit are included at the top of the module.

The module is mechanically keyed to ensure correct replacement with a similar type in the field. I/O references are user configurable without the use of jumpers or DIP switches on the module.

Configuration is done using the configuration function of the MS-DOS® or Windows® programming software running on Windows® 95 or Windows NT® over Ethernet TCP/IP or through the SNP port. The Programming Software configuration function is installed on the programming device. The programming device can be an IBM® XT, AT, PS/2® or compatible Personal Computer.

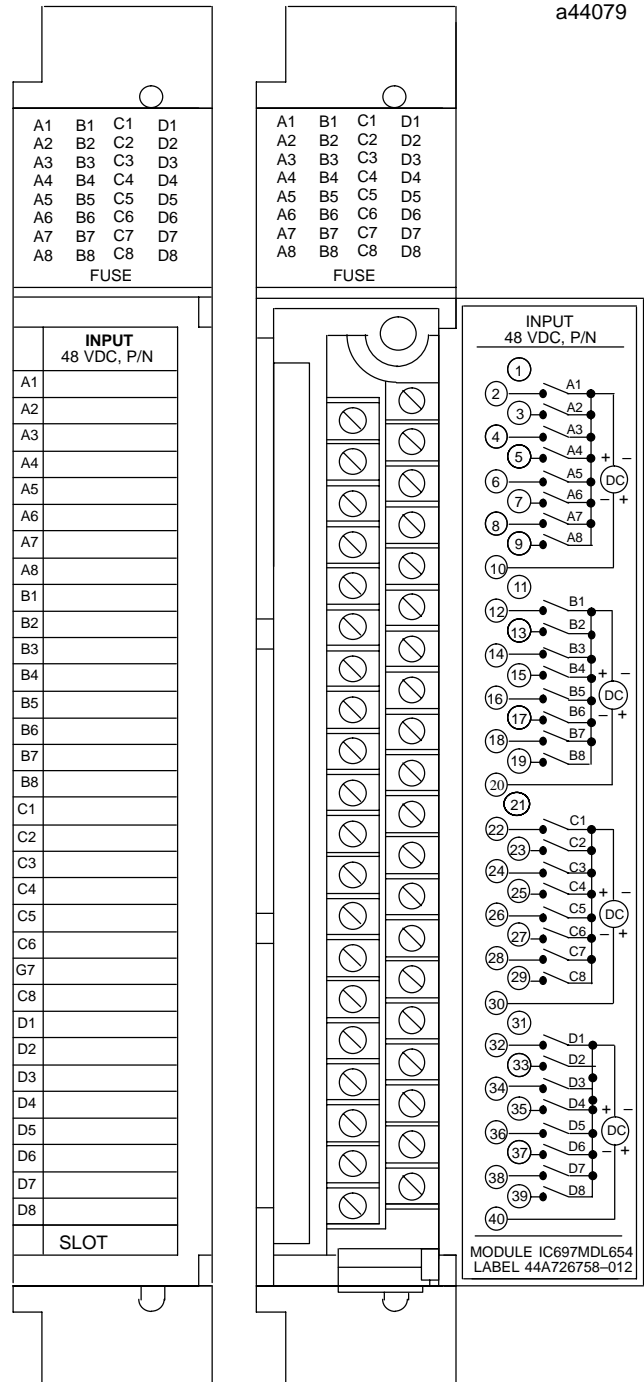

© IBM and PS/2 are registered trademarks of International Business Machines Corporation.

© MS-DOS, Windows, Windows 95, and Windows NT are registered trademarks of Microsoft Corporation.

GFK-0380G  
August 1997

## 48 Volt DC Positive/Negative Logic, 32-Point Input Module

### Operation - 48 Volt DC Pos/Neg Input Module

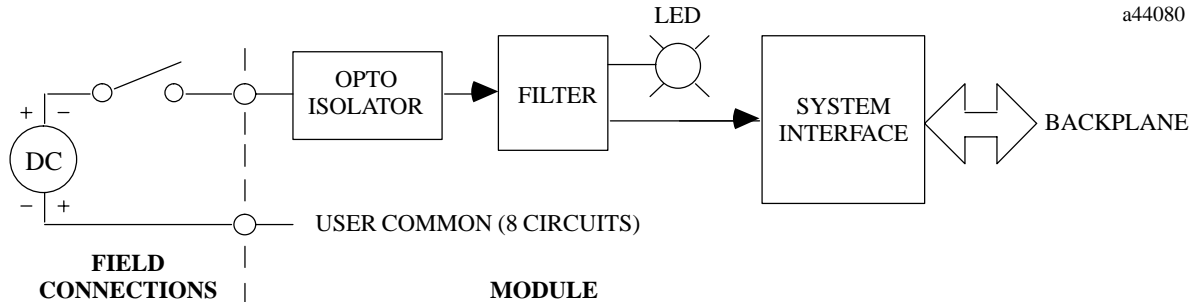

Figure 1. Block Diagram for IC697MDL654

### Input Characteristics

This input module is designed to have both positive and negative logic characteristics - it sinks or sources current from the input device to the user common. The input device is connected between the power bus and the module input as shown above.

This module is compatible with a wide variety of input devices, such as:

- Pushbuttons, limit switches, selector switches;
- Electronic proximity switches, both 2-wire and 3-wire.

In addition, inputs on this module may be directly driven by any IC697 PLC voltage compatible output module.

The input circuitry provides sufficient current to ensure reliable operation of the switching device. Input current is typically 4.7mA in the ON state, and can accept up to 2 mA leakage current in the OFF state without turning on.

3-wire proximity switches are easily applied, since they provide low voltage drop in the ON state and low leakage current in the OFF State.

2-wire proximity switches derive their power from the signal connections; thus both the ON state voltage and the OFF state leakage current are higher than for 3-wire devices. This module is designed to be compatible with many such 2-wire devices; however each device type must be carefully evaluated for compatibility in both the ON and OFF states.

To determine compatibility with a specific proximity switch, find the ON state

characteristics of the switch in the diagram shown below. If that point falls to the left of the input load line, the ON state characteristics are compatible. As an example, the ON state requirements of a compatible proximity switch of 3mA at 5 volts drop are shown below.

OFF state compatibility is assured if the proximity switch leakage is less than 2mA with a module input voltage of 5 volts or less.

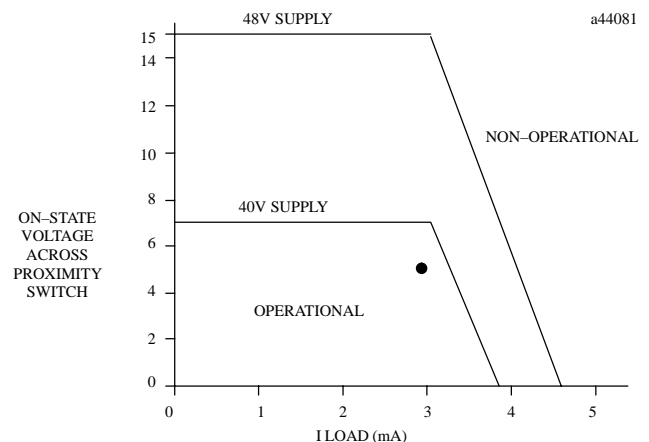

Figure 2. Proximity Switch Compatibility

### Input Filter Selection

With the IC697 PLC and certain other CPU options, this module may be configured to have either a 1mS or 10mS input filter. Configuration is on a module, not per point basis; all points have the same filter time. See the applicable *Programmable Controller Reference Manual* for detailed information.

48 Volt DC Positive/Negative Logic, 32-Point Input Module

GFK-0380G  
August 1997

Interrupt

When used with the IC697 CPU, input point A1 may be configured to cause a CPU interrupt. Configuration allows the CPU to be interrupted on either the rising or falling edge of the signal transition. Interrupt response is not affected by input filter time selection. Refer to the applicable *Programmable Controller Reference Manual* for detailed information.

Module Mechanical Keying

This module includes a mechanical key that prevents inadvertent substitution of one module type for another in a given slot. The key fits a uniquely shaped area on the board below the connector. The key is included with each module.

When the module is first installed, the key latches onto the backplane center rail. When the module is extracted, the key remains in the center rail, configuring the slot to accept only identical module types.

If it is necessary to change the module location in the rack after the key has been latched onto the center rail of the rack, the key can be removed by pushing it upward to unhook the latch while pulling it off the rail. It may then be reinserted onto the module and the module inserted into the rack in the desired location. Note that only the power supply can be placed in the leftmost rack position.

Field Wiring

The module is wired as shown in the illustration on the right of this page. Since each group of eight inputs is isolated from the others, a wire from the power source to the power input terminal for each group (terminal number 10, 20, 30, or 40) is required (power input terminals for each group are not connected inside the module).

The detachable field wiring terminal board will accept wire sizes ranging from #22 (0.36 mm<sup>2</sup>) through #14 (2.10 mm<sup>2</sup>). Two wires may be terminated on a given lug if both wires are the same size. There is room for a bundle of forty #14 (2.10 mm<sup>2</sup>) wires to be routed out through the terminal board cavity.

The wire bundle can be secured to the terminal board by passing a cable tie through a cleat located at the lower corner of the terminal board.

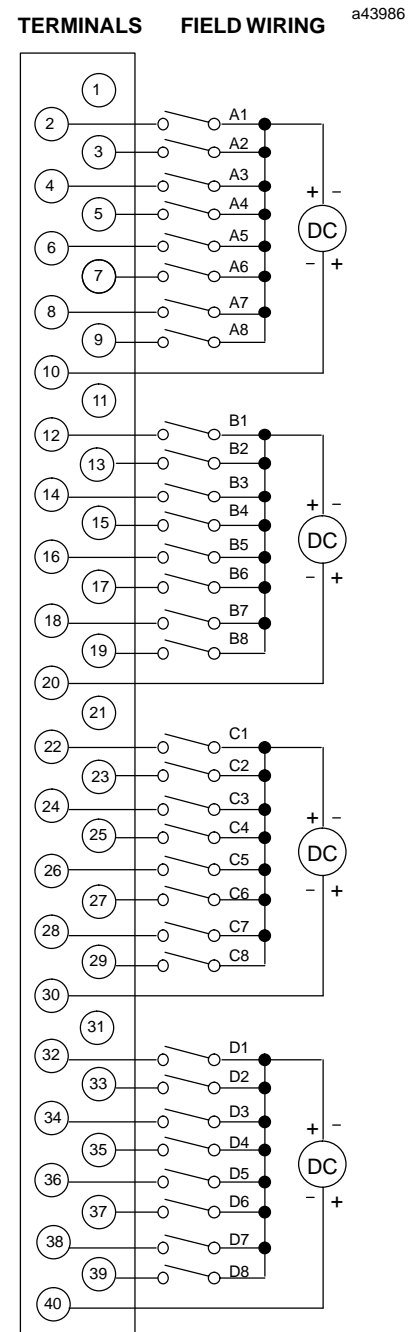

Figure 3. Field Wiring Connections

GFK-0380G  
August 1997

## 48 Volt DC Positive/Negative Logic, 32-Point Input Module

### Recommended Field Wiring Procedures

The following procedures are recommended when connecting field wiring to the detachable terminal board on this input

module. Module features referenced in the following procedures which are common to all I/O modules for the IC697 PLC are illustrated in the following figure.

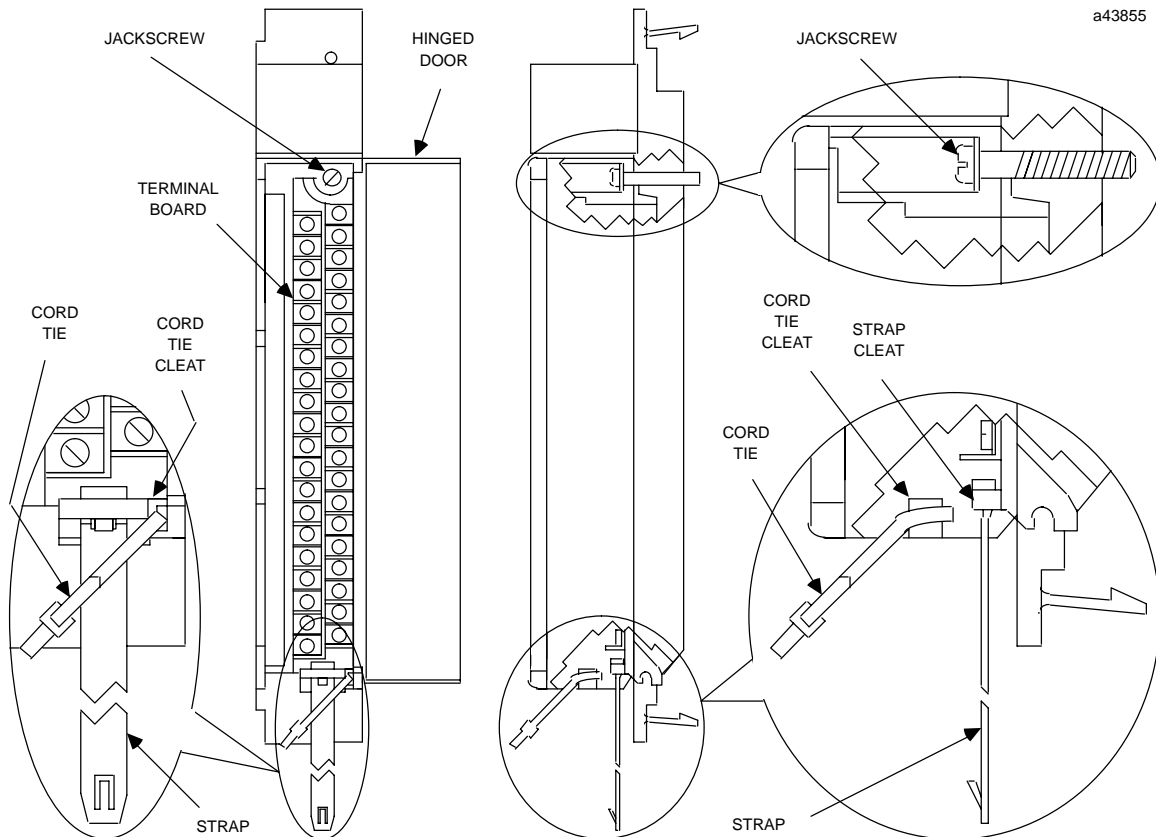

Figure 4. I/O Module Features

1. Turn off power before removing or installing terminal boards. Open the hinged door on the module to access a jackscrew which holds the terminal board securely in place. The detachable field wiring terminal board can now be removed from the module by turning the jackscrew counter-clockwise until it is fully disengaged.
2. To remove the terminal board, grasp the top of the terminal board and swing it outward as shown in Figure 5.
3. The terminal board is designed to accept wire sizes ranging from AWG #22 ( $0.36 \text{ mm}^2$ ) through AWG #14 ( $2.10 \text{ mm}^2$ ). It is important that when using AWG #14 ( $2.10 \text{ mm}^2$ ) wire for wiring all points, that a maximum insulation diameter of .135 inch not be exceeded. To ensure proper connection, two wires may be terminated on any one terminal only if both wires are the same size.
4. The terminal board is designed to accept a maximum of (40) AWG #14 ( $2.10 \text{ mm}^2$ ) wires. If AWG #14 ( $2.10 \text{ mm}^2$ ) wires are to be used, then wire markers should be placed at least 8 inches (203 mm) from termination end to provide sufficient space for the hinged door to close.

### Caution

**Do not use the hinged door to remove the terminal board. The hinged door could be damaged if this is done.**

## 48 Volt DC Positive/Negative Logic, 32-Point Input Module

GFK-0380G  
August 1997

Figure 5. Removal of I/O Terminal Board

5. After completing connections to all modules in a rack, the wire bundle must be secured. To ensure that the wire bundle is secured properly, it is recommended that a cable tie be wrapped around the wire bundle and tightly secured through the cable tie cleat located at the lower right corner of the terminal board. For extremely large wire bundles, additional cable ties should be used.
6. A door label insert is included with each module to indicate circuit wiring information and provide space to record user circuit wiring identification. A slot is provided on the hinged door to allow for insertion of this label. If the label is difficult to insert, crease the scored edge before insertion. The outside label has a color coded stripe to allow quick identification of the module voltage type (blue: low voltage; red: high voltage).
7. After field wiring is completed, the terminal board should be securely fastened to the rack by inserting the terminal board strap (attached to each module) into the small rectangular slots in the bottom card guide grill on the rack. This strap not only secures the terminal board to the rack, it also

provides a way of identifying the wired terminal board with its correct mating rack slot location.

8. For adequate module ventilation, it is recommended that at least a 6 inch (152 mm) clearance be allowed above and below the rack grill. Wire bundles should not obstruct the rack grill work.

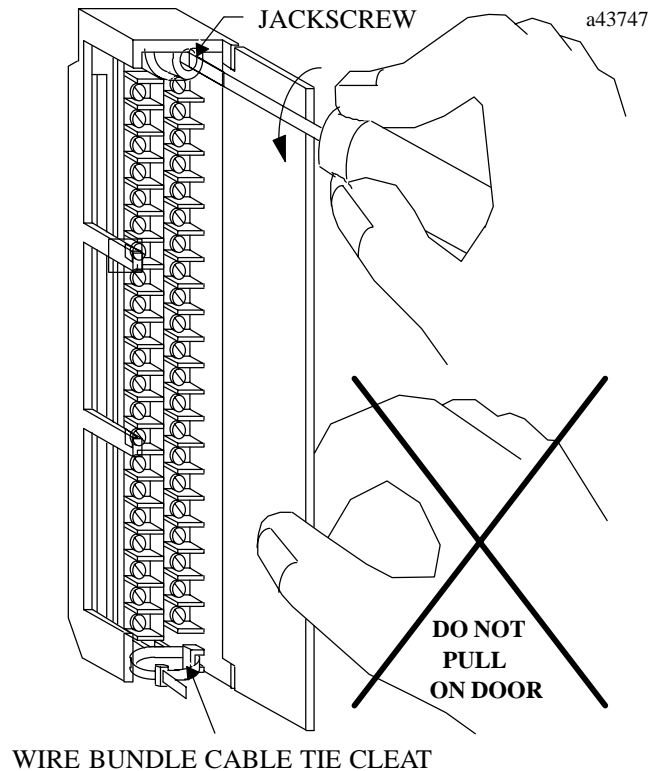
### Removing an I/O Module

The instructions below should be followed when removing an I/O module from its slot in a rack.

- Grasp the board firmly at the top and bottom of the board cover with your thumbs on the front of the cover and your fingers on the plastic clips on the back of the cover.
- Squeeze the rack clips on the back of the cover with your fingers to disengage the clip from the rack rail and pull the board firmly to remove it from the backplane connector.
- Slide the board along the card guide and remove it from the rack.

GFK-0380G  
August 1997

### 48 Volt DC Positive/Negative Logic, 32-Point Input Module

Table 1. Specifications for IC697MDL654 †

<b>Rated Voltage:</b>	48 volts DC
<b>Inputs per Module:</b>	32 (four groups of eight inputs each)
<b>Isolation:</b>	1500 volts RMS - any input to backplane 500 volts RMS between input groups
<b>Input Voltage Range (V<sub>s</sub>)</b>	-3 to +56 volts DC
<b>Input Current:</b>	4.7mA (typical) at rated voltage
<b>Input Impedance:</b>	10.3K ohm, typical
<b>Input Characteristics-</b>	
<b>On-state Voltage:</b>	33 volts to 56 volts
<b>Off-state Current</b>	3mA to 7mA
<b>Off-state Voltage:</b>	0 volts to 10 volts
<b>Off-state Current:</b>	0 to 2mA (2mA minimum at 5V input)
<b>Filter Delay Time:</b>	1 ms or 10 ms configurable
<b>Current Required from 5VDC backplane bus:</b>	0.30amps
<b>VME</b>	System designed to support the VME standard C.1

† Refer to GFK-0867B, or later for product standards and general specifications. For installations requiring compliance to more stringent requirements (for example, FCC or European Union Directives), refer to *Installation Requirements for Conformance to Standards*.

Table 2. Ordering Information

Description	Catalog Number
Input Module: 48 Volt DC Positive/Negative Logic, 32 Points	IC697MDL654

Note: For Conformal Coat option, or Low Temperature Testing option please consult the factory for price and availability.