

# Programmable Controller IC693ACC308 and IC693ACC309

GFJ-041D  
November 1997

## Installation of Base Unit Adapter Brackets

This document describes installation of Base Unit Adapter Brackets for use with the IC693 programmable controllers. **Figure 1:** This bracket (IC693ACC308) allows a 10-slot baseplate to be mounted in a 19I rail. **Figure 2:** This bracket (IC693ACC309) allows IC693 base units to be mounted using existing IC610 programmable controller base unit mounting holes.

As shown in the illustrations, each base unit installation requires only **one** of the applicable Adapter Brackets. Install the Adapter Bracket by inserting the tabs at the top and bottom of the Adapter Bracket into the mating slots at the top and bottom of the base unit.

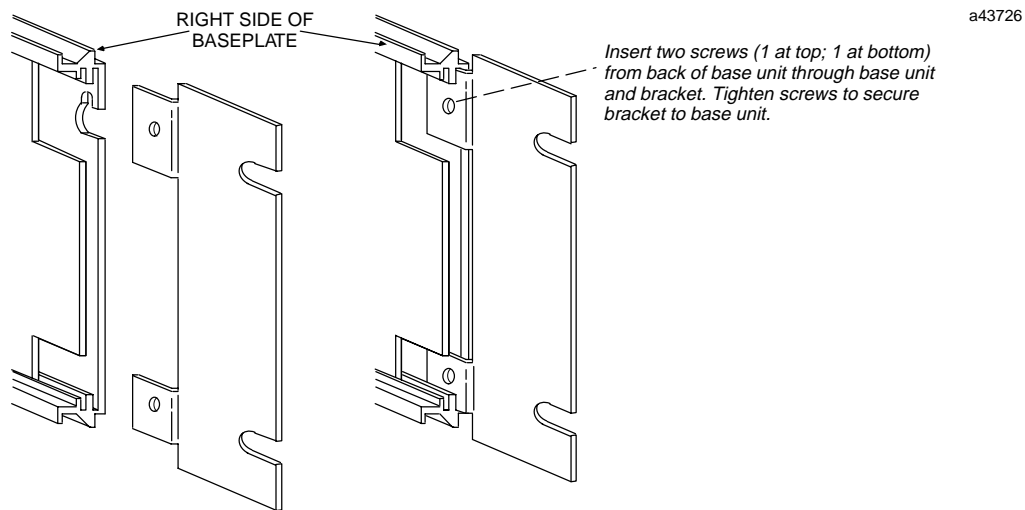

Figure 1. Adapter Bracket IC693ACC308 for mounting an IC693 Programmable Controller 10-Slot Baseplate into a 19" rail.

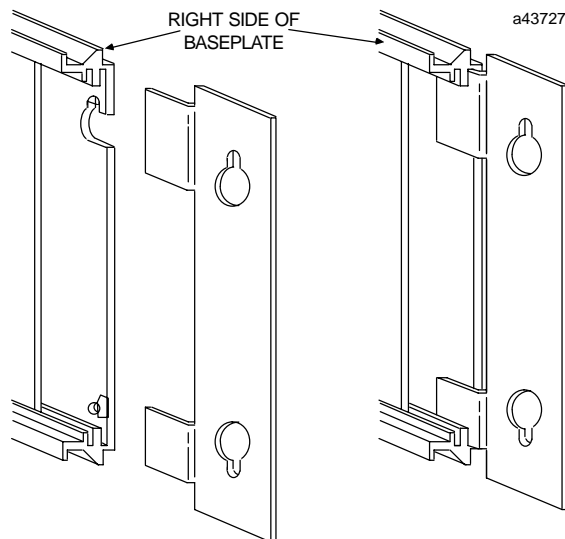

Figure 2. Adapter Bracket IC693ACC309 for mounting IC693 5 and 10-Slot Baseplates using existing IC610 Programmable Controller mounting holes.