

IC693TCM302/303 Temperature Control Modules (TCM)

The Temperature Control Modules (TCM) provides temperature control for up to eight channels. The two TCM models are identical except for temperature range and resolution ratings (see comparison table). They have the following features:

- Can operate in either open loop or closed loop mode
- Each channel has a thermocouple input and a relay output
- RTD input
- 12V common mode voltage capability
- Open and reverse thermocouple detection and reporting
- Out of tolerance temperature detection and reporting

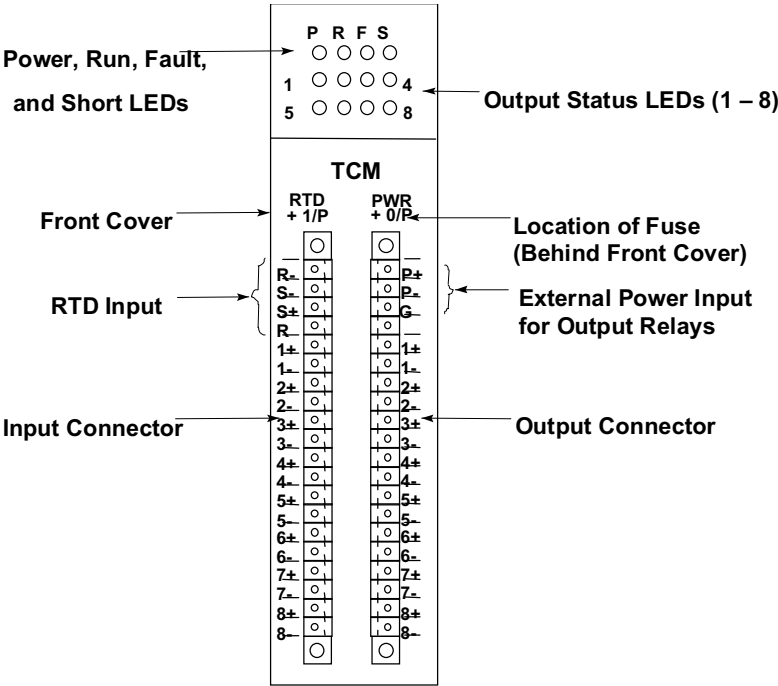

Figure 8-22. IC693TCM302/303 Temperature Control Module (TCM)

Connections

Field devices (thermocouples, relays), RTD and external power for output relays are connected to the module using a pair of plug-in connectors which are supplied with the module. These connectors have captive screw terminals for ease of connecting field wiring. The signal name for each terminal is labeled on the module’s front cover next to each connector, as shown in the drawing above. For example, Channel 8 connections are labeled 8+ and 8- on each connector. Input connections are on the left-hand connector and output connections are on the right-hand connector.

LED Indicators

- **P (External Power)** - This green LED is normally ON, indicating that the module is receiving power. If this LED is OFF, it may indicate that the TCM's internal fuse is open.
- **R (Run)** - This green LED is normally ON. When there is an internal module fault, this LED will alternately flash with the red Fault (F) LED.
- **F (Fault)** - This red LED is normally OFF. This light flashes upon module startup and goes out when the TCM finishes its internal startup routine. When there is an internal module fault, this LED will alternately flash with the green Run (R) LED.
- **S (Short)** - This red LED is normally OFF. This LED lights when there is a short on one of the output circuits.
- **1 – 8 (Output Status)** - These green LEDs normally turn ON and OFF while the module is regulating their outputs. The percentage of time that one of these LEDs is ON versus OFF is representative of the PWM period of that output. Each of the eight LEDs corresponds to an output channel. The output connector is the one on the right side of the module. The channels numbers are labeled on the module next to the connector. For example, LED 8 corresponds to the connections labeled 8+ and 8- on the right-hand connector.

Internal Fuse

The TCM's internal fuse is a 2 Amp, 125V subminiature type (Littlefuse Microfuse, Catalog Number 273 002 or equivalent). If the P (External Power) LED will not light, the internal fuse may be open. To access this fuse:

- Turn off power to the PLC, then remove the TCM module.
- While gently pulling outward on the front cover, release the front cover side tabs with a small ("pocket-size") standard screwdriver.
- Gently remove the fuse by pulling it forward, out of the front of the module, with a small pair of needle nose pliers.

Warning

Replace fuse only with the correct size and type. Using an incorrect fuse can result in harm to personnel, damage to equipment, or both.

Automatic Data Transfers Between TCM and PLC

The PLC CPU controls the TCM by automatically passing commands to it on each PLC sweep. These commands are contained in %Q bits and %AQ words that command such things as Enable/Disable Output, Auto/Manual Mode, Do Autotuning, Setpoint values, and Alarm Limit values.

In return, the TCM sends information to the PLC CPU by automatically passing %I bits and %AI words each PLC sweep. The information sent by the TCM includes Alarm and Output Short Circuit status, Current Temperature, PWM Period, and TCM Error Code.

Comparison of TCM302 and TCM303 Modules

The TCM303 an extended range TCM302 as shown in the table below. For additional information about the TCM, refer to GFK-1466, *Temperature Control Module for the Series 90-30 PLC User's Manual*.

Table 8-1. Comparison of TCM302 and TCM303

Item	IC693TCM302	IC693TCM303
Temperature range, J and L Thermocouples	0 – 450 °C	0 – 750 °C
Temperature range, K Thermocouples	0 – 600 °C	0 – 1050 °C
Resolution	12 bits / 0.2 °C	12 bits / 0.5 °C