

PACSystems* RX3i

IC695PSA140E

GFK-2399F
May 2013

Multipurpose 120/240VAC or 125VDC Power Supply, 40 Watts

The PACSystems[†] RX3i Power Supply IC695PSA140 is a multi-purpose 40-Watt supply that operates from an input voltage source in the range of 85 to 264 VAC or 100 VDC to 300 VDC.

This power supply provides three outputs:

- +5.1 VDC output,
- +24 VDC relay output that can be used to power circuits on Output Relay modules.
- +3.3 VDC. This output is used internally by RX3i modules with IC695 catalog numbers.

This Power Supply is suitable for use in load-sharing and redundancy applications. Up to four Multi-purpose power supplies (PSA140 and/or PSD140) can be used in a PACSystems RX3i (IC695 catalog number) Universal Backplane. Use these Power Supplies if the number of modules required exceeds the capacity of one Power Supply. This Power Supply occupies two backplane slots.

Caution

This Power Supply cannot be used with RX3i IC695PSD040 or IC695PSA040 Power Supplies in redundant or increased capacity modes. Damage to equipment may result.

Load Sharing

When RX3i Multipurpose DC Power Supplies are combined into load-sharing applications following the installation guidelines given in this datasheet, they must be wired to the same power source in such a way that they all can be powered up or powered down simultaneously. The On/Off front panel switch on each of the power supplies must be left in the On position.

Caution

In a load-sharing application, it is important to ensure that the load-sharing power supply modules' On/Off switches cannot be inadvertently used. The minimum number of power supplies needed to meet the system power requirements MUST have their switches always kept in the On position. Also, the load-sharing power supplies must be connected to the system power source through the same external switch. The system must be powered up and powered down only from the external switch. If individual power supplies are powered up or powered down using their On/Off switches or separate external switches, resulting in insufficient power capacity, equipment damage may result. It may be necessary to re-load the PLC operating system to resume operation.

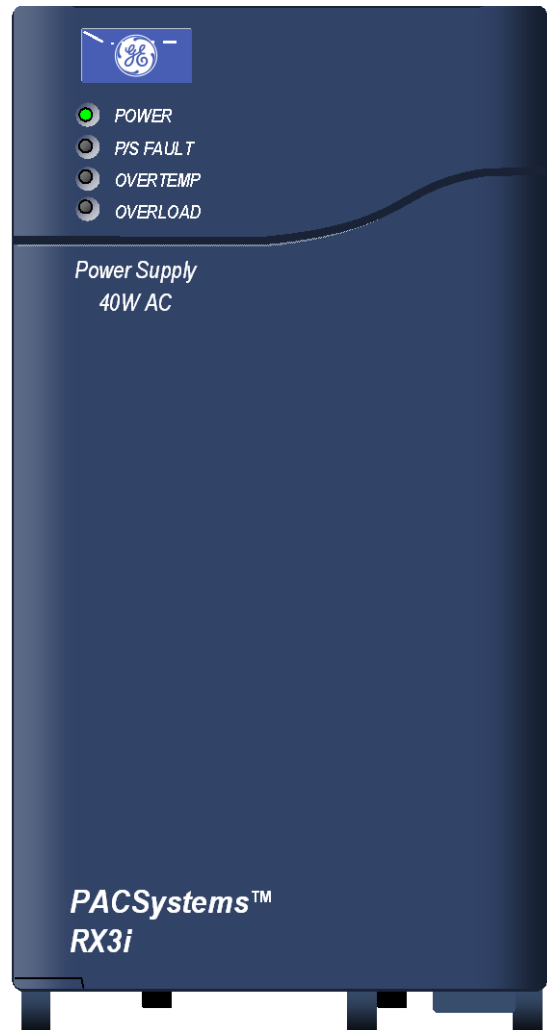

* indicates a trademark of GE Intelligent Platforms, Inc. and/or its affiliates. All other trademarks are the property of their respective owners.

GFK-2399F

Warning

The power supply's door must be closed. During normal operation with an AC power source either 120 VAC or 240 VAC is present on the AC Power Supply. The door protects against accidental shock hazard that could cause severe or fatal injury to personnel.

LEDs

Four LEDs on the Power Supply indicate:

- Power (Green/Amber). When this LED is green, it indicates power is being supplied to the backplane. When this LED is amber, power is applied to the Power Supply but the Power Supply switch is off.
- P/S Fault (Red). When this LED is lit, it indicates the Power Supply has failed and is no longer supplying sufficient voltage to the backplane.
- Over Temperature (Amber). When this LED is lit, it indicates the Power Supply is near or exceeding its maximum operating temperature.
- Overload (Amber). When this LED is lit, it indicates the Power Supply is near or exceeding its maximum output capability on at least one of its outputs.

The CPU Fault Table shows a fault if any Overtemperature, Overload, or P/S Fault occurs.

Wiring Terminals

Terminals for L1 and N/L2 power, ground, and MOV Disconnect accept individual 14 to 22AWG wires.

On/Off Switch

The ON/OFF switch is located behind the door on the front of the module. The switch controls the operation of the outputs of the supply. It does NOT interrupt line power. A projecting tab next to the switch helps prevent accidentally turning it on or off.

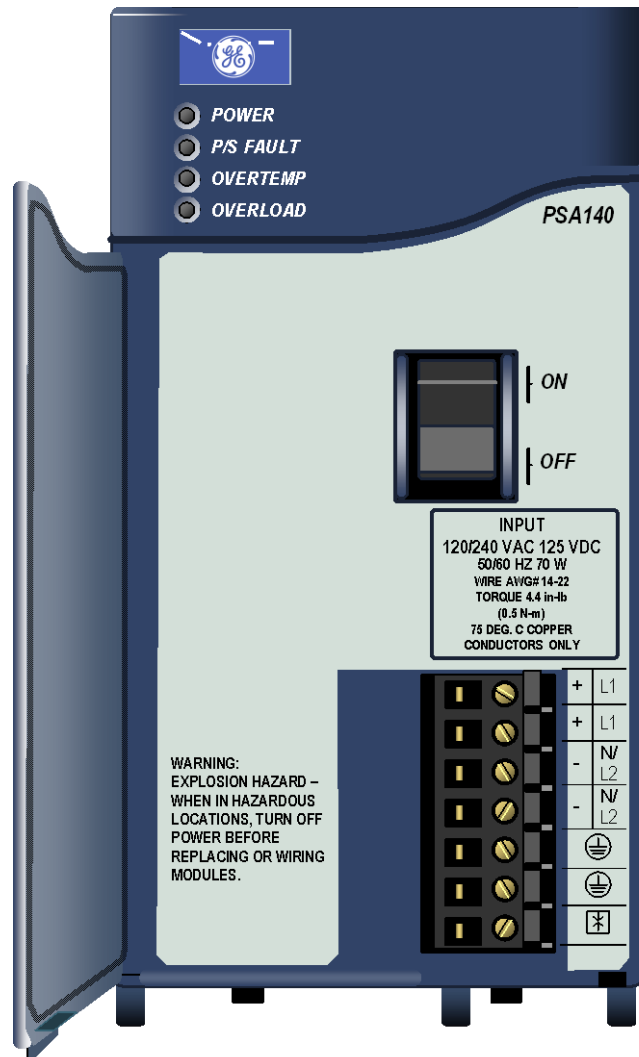

Specifications: IC695PSA140

Nominal Rated Voltage	120/240 VAC or 125 VDC
Input Voltage Range	
AC	85 to 264 VAC
DC	100 to 300 VDC
Input Power (Maximum with Full Load)	70 Watts maximum
Inrush Current	4 Amps, 250 milliseconds maximum *
Output Power	40 Watts maximum total 5.1 VDC = 30 Watts maximum 3.3 VDC = 30 Watts maximum The maximum total output power available depends on the surrounding air temperature, as shown.
Output Voltage	24 VDC: 19.2 VDC to 28.8 VDC, 5.1 VDC: 5.0 VDC to 5.2 VDC (5.1 VDC nominal), 3.3 VDC: 3.1 VDC to 3.5 VDC (3.3 VDC nominal)
Output Current	24 VDC: 0 to 1.6 Amps, 5.1 VDC: 0 to 6 Amps, 3.3 VDC: 0 to 9 Amps
Isolation (input to backplane):	250 VAC continuous; 1500 VAC for 1 minute
Ripple (all outputs)	150 mV
Noise (all outputs)	150 mV
Ride-through time	20 ms. This is the length of time the Power Supply maintains valid outputs if the power source is interrupted
Wiring Terminals	Each terminal accepts one 14 AWG to 22 AWG wire.
Current per Terminal	6 Amps
Number of Daisy-Chained PSA140 Supplies	Up to 4
Number of PSA140 Power Supplies in Universal Backplane	Up to 4

* The Inrush Current specification is given as a guide for sizing the external power source for the IC695PSA140. Peak inrush current may be higher for shorter durations.

For product standards, general operating specifications, and installation requirements, refer to the *PACSystems RX3i System Manual*, GFK-2314.

Installation Information for Hazardous Areas

The following information is for products bearing the UL marking for Hazardous Locations or ATEX marking for explosive atmospheres:

- WARNING - EXPLOSION HAZARD - SUBSTITUTION OF COMPONENTS MAY IMPAIR SUITABILITY FOR CLASS I, DIVISION 2;
- WARNING - EXPLOSION HAZARD - WHEN IN HAZARDOUS LOCATIONS, TURN OFF POWER BEFORE REPLACING OR WIRING MODULES; AND
- WARNING - EXPLOSION HAZARD - DO NOT CONNECT OR DISCONNECT EQUIPMENT UNLESS POWER HAS BEEN SWITCHED OFF OR THE AREA IS KNOWN TO BE NONHAZARDOUS.
- EQUIPMENT LABELED WITH REFERENCE TO CLASS I, GROUPS A, B, C & D, DIV. 2 HAZARDOUS LOCATIONS IS SUITABLE FOR USE IN CLASS I, DIVISION 2, GROUPS A, B, C, D OR NON-HAZARDOUS LOCATIONS ONLY

ATEX Marking

II 3 G Ex nA IIC T3C 0C≤Ta≥60C

Thermal Deratings: PSA140

The maximum output power for Power Supply PSA140 depends on the surrounding air temperature, as shown below.

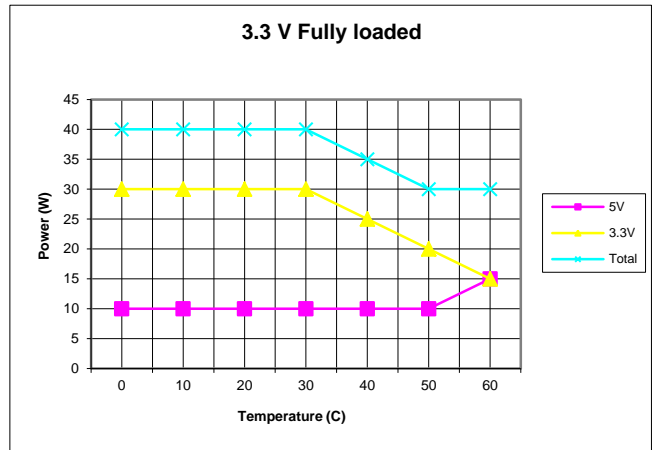
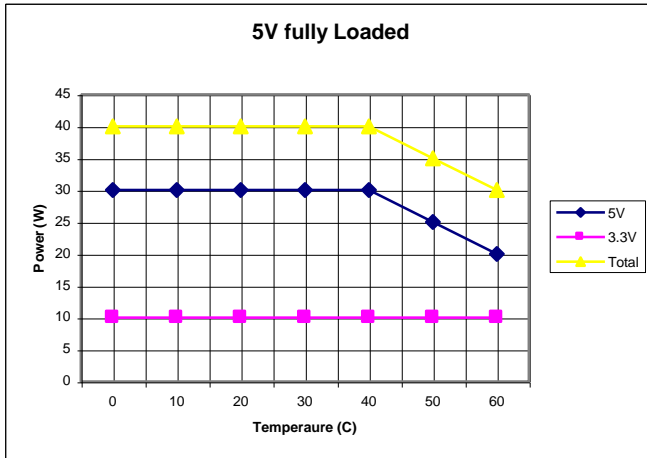

Overcurrent Protection

The 5.1 VDC output is electronically limited to 7 Amps. The 3.3 VDC output is limited to 10 Amps. If an overload (including short circuits) occurs, it is sensed internally and the Power Supply shuts down. Because it is designed for redundancy applications, this Power Supply latches “OFF” in fault conditions and will not automatically try to restart. Input power must be cycled to clear a latched fault. However, if the Power Supply is used in a non-redundant application where automatic restarting is required, a jumper plug can be installed.

An internal non-repairable fusible link in the input line is provided as a backup. The Power Supply usually shuts down before the fusible link blows. The fusible link also protects against internal supply faults. The CPU Fault Table shows a fault if any Overtemperature, Overload, or P/S Fault occurs. There is no additional indication if the Power Supply fusible link blows.

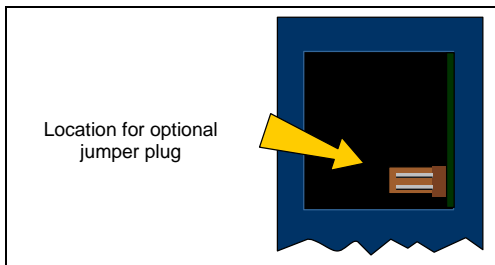

In a non-redundancy application, where automatic restarting may be appropriate, a shunt can be installed on back of the module as shown at left. The shunt must have 0.100 inch spacing on center and accommodate 0.025 inch pins. Example parts are Radio Shack DIP Programming Shunt #276-1512 and DIGI-Key #59000-ND. The module must be removed from the backplane to install the shunt.

Field Wiring: IC695PSA140

Power Source and Ground Connections

The wires from the power source and ground connect to the terminals on the Power Supply as shown at right. Each terminal accepts one AWG 14 to AWG 22 wire.

Warning

If the same external AC power source is used to provide power to two or more power supplies in the system, connection polarity must be identical at each RX3i power supply. A resulting difference in potential can injure personnel or cause damage to equipment. Also, each backplane must be connected to a common system ground.

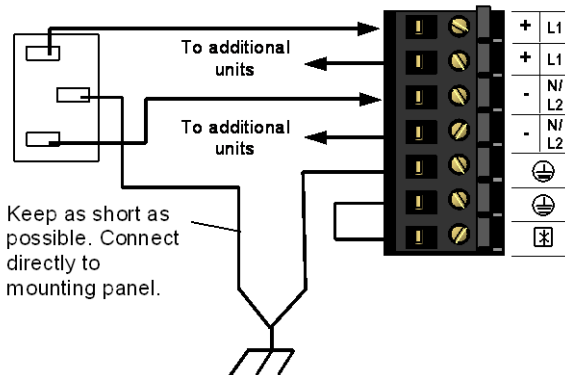

Input Overvoltage Protection

The bottom terminal is normally connected to frame ground with a user-installed jumper as shown at lower right. If overvoltage protection is not required or is supplied upstream, no jumper is required.

To Hi-pot test this supply, overvoltage protection must be disabled during the test by removing the jumper. Re-enable overvoltage protection after testing by reinstalling the jumper.

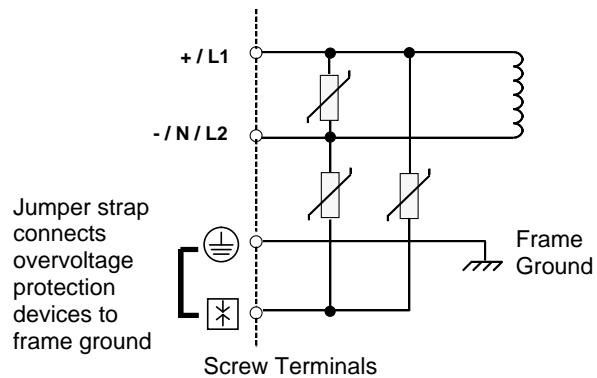

Power Supply Field Wiring Terminals

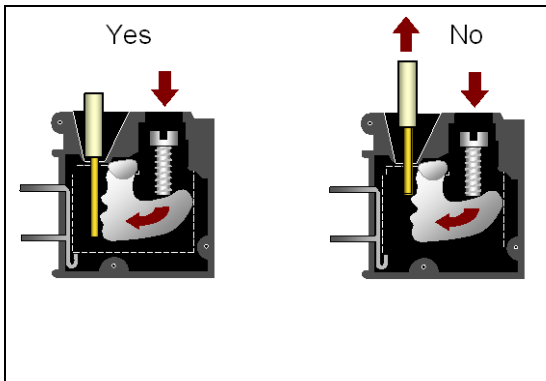

Each terminal accepts one AWG 14 to AWG 22 wire. The end of each wire should be stripped at least 3/8-inch (9mm). The terminal can accept a wire that is stripped up to 11 mm (.433 in) while providing full seating of the insulator. The wire must be fully inserted as shown at left, so that the insulation meets the insulation stop position inside the terminal. Tightening the terminal screw pivots the clamp firmly against the stripped end of the wire, holding it in place. If the wire is not fully inserted as shown at right, tightening the terminal screw may push the wire upward so that it is not connected.

When tightening the screw terminals, do not exceed the maximum torque limit of 0.5 N-m (4.4 inch-lbs).

Connections for Load Sharing

In load-sharing installations, additional Multipurpose Power Supplies above the minimum required for the system load may be wired to the same power source, or a different source.

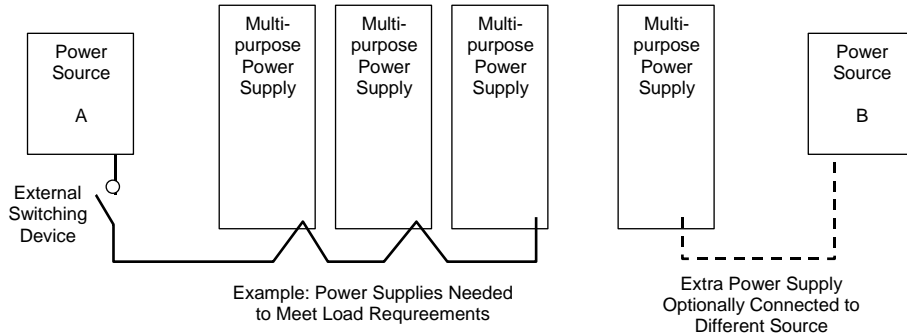

Connections for Power Supply Redundancy

Power Supply redundancy can be provided by using one additional Multipurpose Power Supply above the minimum required for the system power load. In this type of installation, all Multipurpose Power Supplies contribute a share of the backplane power and run at a correspondingly reduced load. This results in longer life for the individual power supplies. In addition, should one power supply module fail, system operation is not interrupted. The front panel switch can be used to remove a redundant unit. Note that this type of system does not provide protection against loss of the input power source. If more than power supply is switched off, the remaining power supplies may become overloaded and shut down. An External switching device must be used to remove power from more than 1 power supply at a time in the Power Supply Redundancy mode.

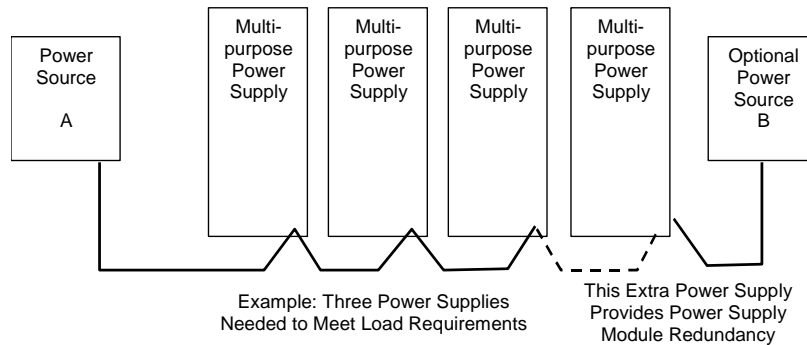

Power Source Redundancy

If the overall power needs of the system can be met using either one or two Multipurpose Power Supplies, then power source redundancy can be provided. This requires using twice the minimum number of Multipurpose Power Supplies required to meet the system load requirements. In this type of system, half of the Multipurpose Power Supplies must be connected to one power source and the other half must be connected to a separate source. This arrangement provides all the advantage of a Basic Redundancy system, as described above, plus power source redundancy. The front panel switch may be used to remove an individual power supply as long as the minimum number of units remain powered up.

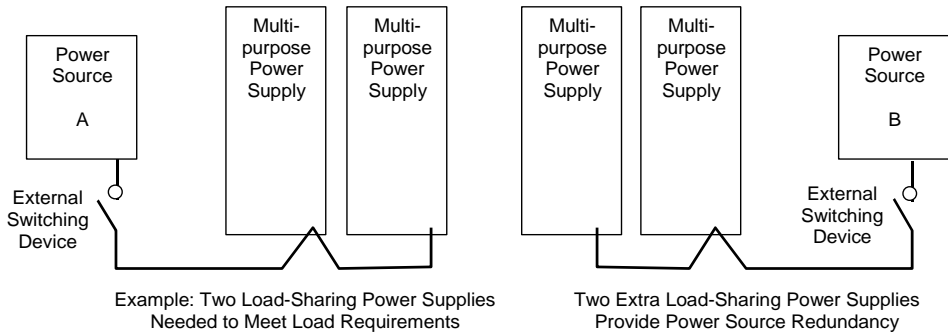

Important Product Information

Revision History

Version	Date	Details
IC695PSA140E	May 2013	Increases the margin of the 5V and 3.3V under voltage detectors to prevent PS faults during power-up.
IC695PSA140D	Aug. 2012	Resolves an issue with powering up under light loads.
IC695PSA140C	Jun. 2011	Hardware modification improves radiated RF susceptibility and removes the requirement to install control systems that use this product in a grounded metal enclosure to meet the EU EMC Directive.
IC695PSA140B	Sep. 2006	Hardware modification. Previous versions of this Power Supply occasionally failed to power up when installed in a 16-Slot Universal Backplane, IC695CHS016. This update resolves the issue.
IC695PSA140A	Sep. 2005	Initial release.

Problems Resolved by this Revision

As part of normal operation, the 5V and 3.3V outputs drop slightly when switched onto the RX3i backplane during the power-up sequence. Some power supplies may respond to this expected voltage drop by indicating a PS Fault and removing power from the backplane. This revision increases filtering in the 5V and the 3.3V under voltage detectors, allowing time for these expected voltage drops to recover before setting a fault.